

# Reliability Engineering

Theory and Practice

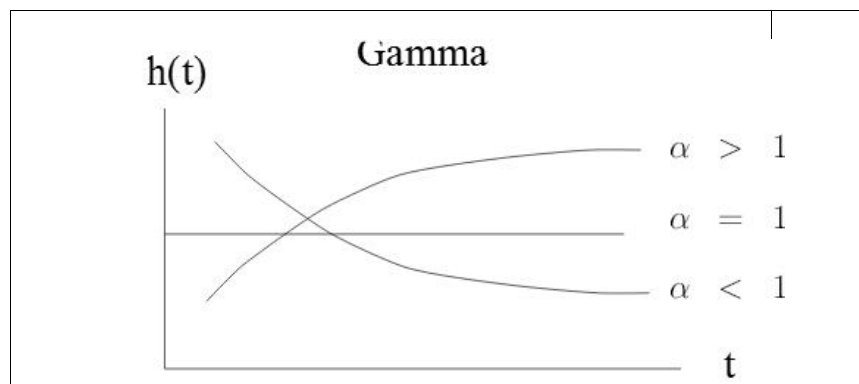

Hamid Bazargan\_Harandi

January 2023

*To my parents*

*The late Mohammad Ali Biazargan (1905-1967)*

*&*

*The late Robabeh Eslampanah (1921-1999)*

C H A P T E R      T I T L E S	
FOREWORD .....	11
Nomenclature .....	13
Chapter <b>1</b> Introduction and Basic Concepts .....	16
Chapter <b>2</b> Static Reliability Models .....	136
Chapter <b>3</b> Reliability in Design + UGF Technique	200
Chapter <b>4</b> Structural Reliability Analysis.....	230
Chapter <b>5</b> On the combinations of random variables in design ;	282
A glance at the tolerance concept.....	282
Chapter <b>6</b> Estimation of Mean Lifetime & Reliability+ Experiments & Tests .....	311
Chapter <b>7</b> Dynamic Models+ Availability, Application of Markov Chain .....	355
Chapter <b>8</b> Enhancement, Optimization & Allocation of Reliability	426
References .....	449
T A B L E S .....	455
About the author .....	476

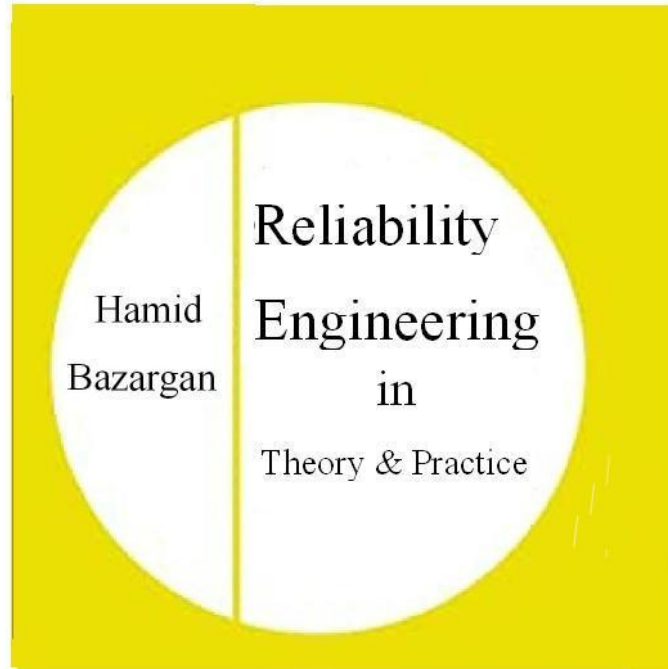

## C O N T E N T S

FOREWORD .....	11
Nomenclature .....	13
Chap <b>1</b> Introduction and Basic Concepts .....	16
Aims of the chapter .....	16
1.1 Introduction .....	16
1-2 Failure .....	17
1-3 Reliability.....	17
1-3-1 abbreviations-----	20
1-4 System reliability function: $R(t)$ .....	22
1-5 Calculation of average lifetime .....	23
1-6 Failure rate .....	26
1-6-1 hazard function for continuous life time distribution	26
1-6-2 Necessary condition for being a hazard function	28
1-6-3 Hazard and relia. functions for discrete distributions ..	29
1-6-4 Calculation of <b>ht, Rt, Ft, ft</b> given any of them	30
1-7 The pdf of a part of a distribution .....	31
1-8 Some continuous distributions used in reliability theory..	32
1-8-1 Exponential distribution -----	32
1-8-2 Normal(Gaussian) distribution	33
1-8-3 Truncated normal distribution -----	35
1-8-4 Log-normal distribution( $\mu, \sigma$ ) --	36
1-8-4-1 Calculation of parameters ----	37
1-8-4-2 Relationship between lognormal & normal	37
1-8-6 Uniform distribution -----	41
1-8-6 Weibull distribution -----	42
1-8-7 GEV distribution-----	46
1-8-8 Gamma distribution-----	46
1-8-8-1 Erlang distribution-----	47
1-9 Bathtub curve hazard function .....	50
1-9-1 Some forms of hazard functions -	53
1-10 Some discrete distributions .....	56
1-10-1 Geometric distribution -----	56
1-10-2 Binomial distribution -----	58
1-10-2 Poisson distribution-----	59
1-11 Accelerated life testing + parametric and non-param. relia analysis.....	62
1-11-1 Accelerated life testing(ALT) -----	62
1-11-2 Parametric reliability analysis -----	63
1-11-3 Non-parametric reliability analysis	63
1-11-3-1 Non-parametric Estimation of <b>ht, Rt, Ft, ft</b> .....	63
1-12 pdf & CDF of sample minimum .....	77
1-12-1 The CDF of the minimum of samples of largish size	79
Fisher -Tippet Theorem.....	91
1-13 Bartlett's goodness of fit test for exponential distribution	93

1-14	Q-Q plot .....	96
1-15	Convolution.....	102
1-15-1	CDF and pdf of sum of variables X and Y	102
1-15-2	n-fold convolution of f with itself	108
1-16	The pdf of the difference of 2 independent random variables	110
1-17	Percentage of a distribution being outside limits	111
Appendix 1	Parameter Estimation Techniques .....	113
	Maximum Likelihood Estimation Method....	114
	Methods of Moments(MOM) .....	121
Appendix 2:	Application of MATLAB in Reliability theory	124
	Exercises .....	132
Chap 2	Static Reliability Models.....	136
	Aims of the chapter .....	136
2-1	Definition of static reliability models .....	136
2-2	Reliability Block Diagram .....	137
2-3	series configuration .....	137
2-4	Parallel configuration .....	140
2-4-1	Types of parallel configurations-----	145
2-4-1-1	Two-component system with 1 active and 1 standby- Perfect switching-----	146
2-4-1-2	n-component system with 1 active and n-1 standby- Perfect switching-----	147
2-4-1-3	Two-component system with 1 active and 1 standby- Imperfect switching .....	149
2-5	Combination of Series and Parallel Configurations	150
2-5-1	Redundancy Level .....	151
2-6	k-out-of-n configuration.....	157
2-6-1	Reliability of k-out-n configuration	158
2-6-1-1	Upper bound for k-out-of-n reliability	164
2-7	Complex System Analysis .....	166
2-7-1	Conditional Probability Method ----	167
2-7-2	Delta-Star Transformation Approach for Reliability Evaluation .....	170
2-7-2-1	Transforming a delta configuration into an equivalent star configuration .....	171
2-7-2-3	Transforming a star configuration into an equivalent delta configuration .....	173
2-8	Calculation of upper and lower bounds for complex system using cut and tie set analysis.....	178
2-8-1	Calculation of reliability upper& lower bounds for complex systems using auxiliary networks-----	183
2-8-2	An approximate formula for the upper and Lower reliability bounds of complex systems .....	187
2-9	Applications of Bays reliability in Design .....	190
	Exercises .....	193

Chap <b>3</b>	Reliability Considerations in Design + UGF Technique	200
	Aims of the chapter .....	200
	3.1 Reliability Considerations in Design.....	200
	3.1-1 Reliability considerations in series configurations	201
	3.1-2 Reliability considerations in parallel configurations	203
	3.1-3 Reliability considerations in series-parallel configurations	206
	3-2 Universal Generating Function(UGF) analysis of Reliability Systems	211
	3.2-1 Moment generating function of discrete random variables	212
	3.2-2 Z-transform or probability generating function of discrete	213
	random variables .....	213
	3-2-3 The Universal Generating Function(UGF)	215
	3-2-4 derivation of the reliability using UGF	222
	3-2-4 Reliability Analysis of Binary -State Systems using UGF	223
	Exercises .....	227
Chap <b>4</b>	Structural Reliability Analysis.....	230
	Aims of the chapter .....	230
	4.1 Introduction .....	230
	4.2 Load-strength Interference Analysis .....	231
	4-3 System reliability -Load & Strength variable .....	233
	4-3-1 Definition of safety margin(SM)-----	234
	4-3-2 Reliability Computation for Probabilistic independent load	244
	and strength .....	244
	4-3-3 Definition of Loading Roughness----	249
	4-3-4 Effect of Safety Margin and Loading Roughness on	253
	Reliability (Multiple Load Applications) .....	253
	4-4 Calculation of structures' reliability Load or Strength deterministic	255
	4-5 Interrelation between reliability(R) and safety factor(SF)	259
	4-6 Determining the structural reliability bounds using nonlinear	261
	programming(NLP).....	261
	4-6-1 The algorithm for Reliability Lower & Upper Bounds using	264
	NLP.....	264
	Appendix : Other definition of safety margin(SM) and its relationship to	275
	safety factor(SF).....	275
	Exercises .....	276
Chap <b>5</b>	Combinations of variables in design +a glance at tolerance	282
	Aims of the chapter .....	282
	5.1 Introduction .....	282
	5.2 Certain properties of a function of some random variables	285
	5.2.1 The pdf of a function of one random variable	285
	5-2-2 Mean of 2 random variables .....	288

5-2-3	Variance of sum and difference of 2 random variables	288
5-2-3-1	Variance of sum of 2 independent random variables	289
5-2-4	Approximating mean and variance of a function of a random variable-----	289
5-2-5	Approximating the mean of a function of some independent random variables -----	290
5-2-6	Approximating the variance of a function of some independent random variables -----	290
5-2-7	Approximating the mean and variance of $XY$	292
5.3	Statistical Tolerance .....	293
5-3-1	Relationship of assembly tolerance parts tolerance	294
5-3-2	Tolerance in complex systems -----	297
	Exercises .....	303
Chap 6	Estimation of Mean Lifetime & Reliability and	311
	Related Experiments & Tests .....	311
	Aims of the chapter .....	311
6.1	Introduction .....	311
6.2	Estimation of product mean life given a lifetime sample of size n	312
6.3	Tests for Estimating Mean Life .....	312
6.3.1	Time censoring (Type-I)-----	313
6.3.2	failure censoring (Type-II) -----	313
6.4	Estimation of mean life .....	314
	Calculation of T for $MTTF = MTBF = \theta = Tr$	315
6-4-1	Type I censoring life test -----	316
6-4-1-1	Type I censoring life test with replacement	316
6-4-1-2	Type I censoring life test without replacement	318
6-4-2	Type -II censoring life test -----	320
6-4-2-1	Type II censoring life test without replacement	320
6-4-2-2	Type II censoring life test with replacement	321
6-5	On the Accelerated life testing (ALT) .....	323
6-6	Confidence interval for mean lifetime-exponential distribution case	324
6-6-1	Lower-bound confidence interval (CI) for mean of exponential distribution -----	330
6-6-2	The confidence interval for the time during which fraction p of exponentially-distributed-life products fail ---	330
6-7	Reliability Acceptance Sampling Plans .....	331
6-7-1	Type I&II errors of Sampling plans	333
6-7-2	Design of single plans using Table 6-2	333
6-7-3	The operating characteristic (OC) curve of single sampling plans -----	336
6-7-3-1	OC curve for single sampling plans	336
6-8	statistical hypothesis testing on mean and minimum lifetime	341
6-8-1	Test of hypothesis on minimum life of an exponentially distributed lifetime (K&L page 263) -----	342



6-8-2 Test of hypothesis on mean lifetime and failure rate concerning exponential distribution(K&L page263)	344
Exercises .....	348
<b>Chap 7</b> Dynamic Models+ Availability, Applic. of Markov Chain	355
Aims of the chapter .....	355
7.1 Dynamic Models in Reliability .....	355
7-1-1 Series Systems .....	355
Mean lifetime and reliability function of a series system of identical components with failure rate $\lambda$ .....	359
7-1-2 Series Chain Model or Weakest Link Model	359
7-1-3 Parallel systems.....	364
7-1-3-1 Reliability in active redundancy -	365
7-1-3-2 Reliability and MTBF in active system with exponentially- distributed-lifetime components	366
7-1-3-3 Reliability of standby parallel system	370
Life pdf & reliability for Perfect switch: 2-component standby system.....	382
Special case: Constant failure rate & perfect switch( $P_s = 1$ )	383
Life pdf & reliability for Perfect switch: 3-component standby system.....	384
Reliability of n-component standby system :Perfect Switch	385
Imperfect switch ,2-component standby system	387
2-component standby , constant failure rate-	387
Imperfect switch with reliability $P_s$ .....	387
2-component standby , constant failure rate-	388
Imperfect switch with reliability function $R_s(t)$	388
2-component standby system with similar units, imperfect switch and warm redundant unit.....	394
7-1-4 Shared load parallel configuration ----	399
Special case:2-component constant failure rates	400
7-2 System Effectiveness Measures .....	402
Serviceability .....	402
Maintainability .....	403
Maintainability function .....	403
Operational readiness(OR).....	405
7-3 Availability .....	407
7-3-1 Intrinsic Availability.....	407
7-3-2 Availability function.....	408
7-3-3 availability function for nonrepairable systems	410
7-3-4 Steady state availability .....	410
7-3-5 Intrinsic availability in long range .....	413
7-3-6 Mission Availability .....	415
7-3-7 System Availability in terms of components' Availability	417
7-3-8 The steady-state availability in Preventive Maintenance	419
7-3-9 Definition of Unavailability Function	420

---

7-4 Application of Markov Chains to System Reliability Analysis	421
Exercises .....	424
<b>Chap 8</b> .....	426
Enhancement, Optimization & Allocation of Reliability	426
Aims of the chapter .....	426
8-1 Enhancement(Improvement) of system reliability	426
8-1-1 Improving Component reliability-----	426
8-1-2 Hot and standby redundancy-----	427
8-1-2 Active redundancy-----	428
8-1-2 Standby redundancy-----	428
8-2 Reliability Optimization.....	430
8-2-1 Methods for the solution of The above problems	434
8-3 Reliability Allocation .....	435
8-3-1 Equal Apportionment Technique -----	438
8-3-2 The ARINC technique -----	441
8-3-3 The AGREE allocation method -----	443
Exercises .....	448
<b>References</b> .....	449
Table A Critical values of F distribution $F_{m,n}$ .....	456
Table B Values of CDF of Poisson Distribution .....	460
Table D Critical values of standard normal ( $Z\alpha$ ) ....	467
Table E Critical values of Chi2 Distribution-----....	469
Table F Characteristic continuous distributions .....	471
Table G Characteristic of discrete distributions .....	474
Table H MATLAB commands for distributions .....	475

## FOREWORD

This book, whose Persian version written by the same author is published by our university, is the outcome of teaching a course on reliability for several years to graduate students using many books especially the book written by Dr Kapur and Lamberson (abbreviated by K&L throughout the book). The main prerequisite for understanding the materials of the book is probability. As evident from the chapter titles, the book introduces readers with reliability and availability of products. I would like to the students who helped the author in some phases of editing.

At the end of this foreword a software and a symposium are introduced.

### Software

ReliaSoft's reliability software tools facilitate a set of reliability engineering modeling and analysis techniques. (downloadable from <http://www.reliasoft.com>)

**A symposium:** RAMS associated to IEEE

Reliability and Maintainability [www.rams.org](http://www.rams.org)

The proceedings are available from

<http://ieeexplore.ieee.org/xpl/mostRecentIssue.jsp?punumber=6516162>

It is suggested to the readers, especially those working in industry, to read books on design for reliability after reading this book.

Thanks God for making me successful to present this work which I hope to be useful in both academic and industrial environments.

The author would be pleased if the readers write him about any kind of deficiencies in the book.

Hamid Bazargan

Jan 2023

College of Engineering,

Shahid Bahonar University of Kerman, Iran

[bazargan@uk.ac.ir](mailto:bazargan@uk.ac.ir)

**The wise is one who puts everything  
in its right place**

## Nomenclature

Symbols	Description
<b>A,B,C</b>	
A	1)steady-state availability 2)Location parameter of Weibull distribution
$A_i$	Intrinsic Availability
a.r.t	actual repair time
B	1)a parameter of some distributions (Weibull , GEV, GPD) 2) Bartlet's test
C	1)A parameter of some distributions (Weibull , GEV, GPD)
CDF	Cumulative distribution function
<b>F</b>	
$F_X$	CDF of random variable X
$F_Y$	CDF of random variable Y
$f_{sys}$	pdf of system's lifetime
$f_X$	pdf of random variable X
$F_\delta$	CDF of strength
$f_S(s)$	pdf of stress(load)
$F_\delta(s)$	CDF of strength
$f_\delta(\delta)$	pdf of strength
$F_{X(i)}$	pdf of sample min.
$F_X * F_Y$	convolution of $F_X, F_Y$
$F_{\alpha, mn}$	critical value of F distribution for n & m degrees of freedom at given sig. lev. $\alpha$
$F_{\frac{\alpha}{2}, 2r_2 - 2, 2r_1 - 2}$	critical value of F distribution for $2r_2 - 2$ & $2r_1 - 2$ deg. of f. at lev. $\alpha/2$
<b>H,L,N,O</b>	
$h(t)$	Instantaneous failure rate function
L	Lower Specification Level

## Nomenclature

n	1)sample size 2)the number of components in a series or parallel configuration
$\bar{n}$	Average safety factor
$n_i$	Number of components in $i^{th}$ subsystem
$N_0$	Initial size of the sample
$\bar{N}(t)$	The number of survivor components (or the number still working adequately)at time t
OR	Operational readiness
<b>P,Q</b>	
p	Failure probability of a device
pdf	Probability density function
$P_S$	The probability that a switch operates well
$P_a$	The probability of accepting a lot by a sampling plan
$P_i(t)$	The probability that the system is in state $i$ at time t
$p'$	Fraction defective in a population
Q	Failure (unreliability) probability of a device
$Q_i$	Failure probability of $i^{th}$ component
<b>R</b>	
$R^*(t)$	The optimum reliability of the system at time t
$R_0$	The required reliability of the system
$R_i^*$	The reliability allocated to $i^{th}$ unit
$R_i$	The given reliability for $i^{th}$ unit
$R_n$	The reliability of n-component system(a active)
$R_{sys}^2$	The reliability of 2-component system (1 active 1 standby)
$R_{standby}^2$	The reliability of 2-component system( both active)
$R_{active}^2$	The reliability of 2-component system (1 active 1 standby)
$R_s(t)$	The reliability function of the switch
$R_{sys}(t)$	System reliability function

## Nomenclature

$R_i(t)$  The reliability function of  $i^{\text{th}}$  unit

## S, T

**S** Stress, Load  
 $S_{\text{max}}$  Maximum of stress(load), upper extreme value of S  
 $S_{\text{mean}}$  Average stress value  
 $S_{\text{min}}$  Minimum of stress(load), lower extreme value of S  
 $t^*$  Duration of experiment  
**T** Total operating time of all items under the lifetest

## U, V, W, X

**U** The upper specification level of a dimension of a product  
 $(U - L)_{\text{part}}$  The difference of U and L in a part  
 $(U - L)_{\text{sum}}$  The difference of U and L in the assembled unit  
 $V_n$  Coefficient of variation of safety factor(SF)  
 $w_i$  In AGREE Method: The importance factor of the  $i^{\text{th}}$  subsystem  
 $X_{(1)}$  The minimum of a sample  
 $X_{(i)}$  The  $i^{\text{th}}$  value of an ordered sample  
 $X_i$  The  $i^{\text{th}}$  value of a sample; The occurrence time of the  $i^{\text{th}}$  Failure; the  $i^{\text{th}}$  failure time of the device

$$\text{Note : } \sum_{i=1}^r X_{(i)} = \sum_{i=1}^r X_i$$

## $\alpha, \beta, \dots$

$\alpha$  The probability of Type I error  
 $\beta$  The probability of Type II error  
 $\delta_i$  The strength of the  $i^{\text{th}}$  link (component)

## Nomenclature

$\lambda_a$  The failure rate of component a  
 $\lambda_b$  The failure rate of component b  
 $\lambda_f$  In load sharing: the failure rate for the component under half load  
 $\lambda_g$  In load sharing: The failure rate for the component under full load

$\lambda_s$  The failure rate of the switch  
 $\lambda^+$  The failure rate of the standby component while in standby mode  
 $\mu$  The mean of a population

$\mu_S$  Average load  
 $\mu_\delta$  Average strength  
 $\sigma$  The standard deviation of a population  
 $\sigma_S$  Standard deviation of load distribution  
 $\sigma_\delta$  standard deviation of strength distribution  
 $\delta_{\text{min}}$  lower bound of strength

$\sigma_{\text{part}}$  the standard deviation of a measurement in a part  
 $\sigma_{\text{sum}}$  the standard deviation of a measurement in the assembly

$\varphi_Z$  the CDF of standard normal distribution

$\varphi_X$  moment generating function of random variable X

$\chi_{\alpha, n}^2$  The critical value of chi-squared distribution with degree. free = n and sig. level =  $\alpha$

$\otimes_\phi$  or  $\otimes_f$  composition operator acting over a function (in UGF Technique)  
 End of Example



End of theorem ; End of proof



# Chapter 1

## Introduction

### &

## Basic

## Concepts

# 1

## Introduction and Basic Concepts

### Aims of the chapter

This chapter is concerned with definitions and basic concepts needed in a reliability course such as MTTF, MTTR, reliability function, hazard function and their estimation. Bathtub curve, cumulative distribution function of extreme values of samples are also discussed and a goodness of test for exponential distribution is explained.

### 1.1 Introduction

In general, the reason one is concerned with the reliability of components of electrical and mechanical systems is to ensure that the systems will be reasonably free from failure (Grant & Leavenworth, 1988 page 606). Failure of products could incur a great loss or lead to personal injury, or severe physical or environmental damage and even lead to death. This proves the importance of product reliability in various fields including air-space. According to Bazovsky (2004) "reliability has added a new dimension to quality control work without subtracting anything from traditional quality control work and methods."



Here the quality characteristic is life. Gathering of lifetime data is often expensive and its statistical analysis is an important topic in reliability engineering. It is reminded that control charts such as  $\bar{X}$  chart and p-chart could be constructed using lifetime data but these charts, despite their effectiveness, do not answer such questions as what percent of the products live more than 1000 hours with 90% of probability. Before defining the term reliability let us define the term failure.

### **1-2 Failure**

American National Standard defines failure as "The termination of the ability of any item to perform its required function (IIE Terminology page 8-9).

### **1-3 Reliability**

In general reliability is the ability of a device, a system or a unit to perform a function or some required functions without any failure under some conditions for a stated amount of operation. The amount of operation could be expressed in time, kilometers, working cycles, number of times it operates....

When defining this characteristic by such terms as "assessed reliability" and "predicted reliability" the following is useful

IIE terminology defines this term as " the probability that an item will perform a required function under stated conditions for a stated period of time" (IIE Terminology page 8-22).

The reliability is sometimes expressed as a success ratio.

### **The objectives of Reliability Engineering**

The Reliability Engineer must<sup>1</sup>

- Apply engineering knowledge and techniques to reduce the occurrence of failures
- Determine the cause of each failure and make necessary adjustments to correct the issue or completely address the root cause
- Identify different ways to address failures should the root cause prove uncorrectable
- Do reliability estimations for new designs and continually analyze reliability data

Moreover reliability engineers check new installations to ensure they adhere to functional specifications. They guide users to ensure the reliability and maintainability of equipment, processes, utilities, facilities, controls, and safety/security

---

<sup>1</sup> From (<https://www.techslang.com/definition/what-is-reliability-engineering/>)

systems. That includes helping them come up with asset maintenance and risk management plans.

Reliability engineers develop solutions to repetitive failures and all other problems that adversely affect the users' operations. They work with production teams to analyze assets' performance.

Overall, reliability engineering can minimize failures, enhance effectiveness, reduce repair times, streamline maintenance processes, and offer protection against injuries and death. (End of quotation from <https://www.techslang.com/definition/what-is-reliability-engineering/>)

Also reliability engineers must

- Be able to enhance and optimize systems' reliability

### **Reliability Importance: The Reasons**

Some of the reasons why product reliability is important are:

-Greater safety for industries such a space industry

-Greater product reliability causes more reputation

-Customers' request and consent

-Although greater reliability incur a higher cost, but the overall cost including that of maintenance and repair is less.

It is worth mentioning that reliability theory has application to many fields including air-space industry, home appliances, transportation, buildings, and electronic industry.

### 1-3-1 abbreviations

TTF	Time To Failure,
TTR	Time To Repair, repair time
TBF	time between 2 successive failures( for repairable devices)
MTTF	Mean Time to failure
MTTR	Mean Time to Repair
MTBM	Mean time between maintenance, The average length of time between one maintenance action and another for a component
MTFF	Mean time to first failure
MTBF	Mean time between failures( for repairable devices)

Note that TBF is equal to the sum of TTR and TTF (Fig.1.1).

$$TBF = TTR + TTF \quad (1-1-1)$$

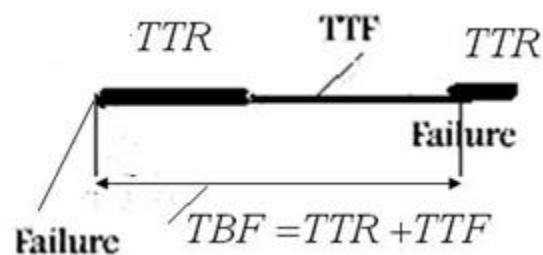

Fig. 1.1 Graphical representation of Eq. 1.1.

Taking the average of both sides of Eq. 1-1-1 yields:

$$MTBF=MTTR+MTTF \quad (1-1-2)$$

If the probability distribution function or the cumulative distribution function of the time between failures is not known, mean time between failures(MTBF)could be estimated from (Tersine, 1985, p202):

$$M\hat{T}BF = \frac{WT}{N} \quad (1-2)$$

Where  $N$  is the number of failures during the time  $WT$ .

Mean time to failure (MTTF) and mean time to repair(MTTR) could be estimated in a similar manner.

In the continuation of this section, some terms used for measuring reliability such as reliability function, mean life time, hazard function or failure rate function are described. It is worth remembering that since we accept that in a population of a product, the products fail in different times, even if they work under the same conditions, it is concluded that the failure phenomena has to be treated statistically. That is why the definition of reliability basics concepts is based on Profanity theory.

### 1-4 System reliability function: $R(t)$

Reliability function for devices with continuous lifetime distribution is defined as:

$$R(t) = \Pr(X > t) = \Pr(X \geq t) = \int_t^{\infty} f(x)dx = 1 - F(x) \quad (1-3)$$

where

$f(x)$  is the probability density function(pdf) of time to failure ( $X=TTF$ ),

$F(x)$  is the cumulative distribution function of lifetime( $X$ ),

Reliability function for devices with discrete lifetime distribution is defined as:

$$R(k) = \Pr(X > k) , k = 1, 2, \dots \quad (1-4-1)$$

$$R(k) = \sum_{j=k+1}^{\infty} P_X(j), \quad (1-4-2)$$

Where  $P_X(j)$  is the failure probability at time  $j$ .

For example if the failure probability at any time is  $p$  and the distribution is geometric, then the reliability of time  $j$  is:

$$R(k) = (1 - p)^{k+1} , k = 1, 2, \dots \quad (1-5)$$

If  $k$  is largish and  $p$  is small, then:

$$R(k) \cong e^{-(k-1)p} . \quad (1-6)$$

### 1-5 Calculation of average lifetime

If the lifetime is a continuous random number with probability density function  $f(x)$  of cumulative distribution  $F(x)$ , its average is calculated from:

$$E(X) = \int_{-\infty}^{\infty} xf(x) dx. \quad (1-7)$$

It is proved that for a continuous distribution:

$$E(X) = \int_0^{\infty} [1 - F_X(x)] dx - \int_{-\infty}^0 F_X(x) dx \quad (1-8)$$

And since lifetime(X) does not accept negative values, then lifetime average could be calculated from:

$$E(X) = \int_0^{\infty} [1 - F_X(x)] dx \quad (1-9)$$

or from :

$$E(T) = \int_0^{\infty} R(t) dt. \quad (1-10)$$

It worth noting that 2 systems with equal lifetime average might have different reliability.

**Example 1-1**

If  $X$  with normal distribution  $X \sim N(\mu = MTBF, \sigma)$  and  $Y$  with exponential distribution  $Y \sim \exp\left(\lambda = \frac{1}{\theta} = \frac{1}{MTBF}\right)$  represent the lifetimes of 2 products, find the average lifetime and the reliability of each product for a mission time equal to  $t = MTBF$ .

**Solution**

$X$  is normally distributed; then

$$E(X) = \mu = MTBF, \quad R(t = MTBF) = \Pr(X > \mu) = \frac{1}{2}$$

$Y$  is exponentially distributed, then:

$$E(Y) = \theta = MTBF, \quad R(MTBF) = e^{-\frac{\theta}{\theta}} \cong 0.37 \blacktriangle$$

**Example 1-2**

The life time of a critical component is exponentially distributed with parameter  $\lambda$ . If the component fails or if its lifetime reaches  $T$  it is replaced with a new one. How much time on the average is needed to replace the component?



### Solution

Let

$X$  = the life time of the component and

$Y$  = the replacement time.

$$Y = \text{Min}(X, T) \Rightarrow E(Y) = E[\text{Min}(X, T)]$$

$$\text{Min}(X, T) + \text{Max}(X, T) = X + T \Rightarrow$$

$$E[\text{Min}(X, T)] = E(X + T) - E[\text{Max}(X, T)]$$

$$E(X + T) = E(X) + T$$

$$E\{\text{Max}(X, T)\} = E(\text{Max}(X, T) | X > T) \Pr(X > T) \\ + E(\text{Max}(X, T) | X \leq T) \Pr(X \leq T)$$

$$E(\text{Max}(X, T) | X > T) = E(X | X > T),$$

$X$  is exponentially distributed and therefore is memoryless; then:

$$E(X | X > T) = T + \frac{1}{\lambda} \text{ and } E(\text{Max}(X, T) | X \leq T) = E(T) = T.$$

then

$$E\{\text{Max}(X, T)\} = \left(T + \frac{1}{\lambda}\right) \times e^{-\lambda T} + T(1 - e^{-\lambda T}) = T + \frac{1}{\lambda} e^{-\lambda T}$$

$$\begin{aligned} E(Y) &= E\{\text{Min}(X, T)\} = E(X + T) - E[\text{Max}(X, T)] \\ &= \frac{1}{\lambda} + T - \left(T + \frac{1}{\lambda} e^{-\lambda T}\right) \Rightarrow E(Y) = \frac{1}{\lambda} (1 - e^{-\lambda T}) \blacktriangle \end{aligned}$$

## 1-6 Failure rate

The probability of failure of a system in a given interval  $[t_1, t_2]$  is (K&L page 12):

$$\Pr(t_1 < X < t_2) = F_X(t_2) - F_X(t_1) = R(t_1) - R(t_2).$$

conditioning on the event the item is working at time  $t_1$

$$\Pr(t_1 \leq X \leq t_2 | X > t_1) = \frac{F_X(t_2) - F_X(t_1)}{R(t_1)} = \frac{R(t_1) - R(t_2)}{R(t_1)}$$

If this conditional probability is averaged over  $[t_1, t_2]$  an average rate of failure is obtained from the following (Ravindran, 2016 p17-12)

$$\frac{\Pr(t_1 < X < t_2 | X > t_1)}{t_2 - t_1} = \frac{\frac{R(t_1) - R(t_2)}{R(t_1)}}{t_2 - t_1} = \frac{R(t_1) - R(t_2)}{(t_2 - t_1)R(t_1)}$$

This is called the failure rate during interval  $[t_1, t_2]$  (K&L p12).

### 1-6-1 Instantaneous rate function (hazard function) for continuous life time distributions

In the above expression, let  $[t_1, t_2] = [t, t + \Delta t]$  then the average rate of failure would be

$$\frac{R(t) - R(t + \Delta t)}{\Delta t \times R(t)}.$$

When  $\Delta t$  approaches zero ( $\Delta t \rightarrow 0$ ) in the above fraction, a function called instantaneous rate function or hazard function is obtained:

$$h(t) = \lim_{\Delta t \rightarrow 0} \frac{R(t) - R(t + \Delta t)}{(\Delta t) \times R(t)} = \frac{1}{R(t)} \left[ -\frac{dR(t)}{dt} \right] = \frac{f(t)}{R(t)}, \quad (1-11)$$

Then for devices with continuous lifetime having pdf  $f(t)$  and reliability (survivor) function  $R(t)$ , the hazard function is defined as the ratio of the probability density function to the survivor function.

$$h(t) = \frac{f(t)}{R(t)} = \frac{-R'(t)}{R(t)}. \quad (1-12)$$

The ratio is a function of  $t$ . In practice,  $t$  could be time, number of cycles or revolutions, km, events, ....

$h(t)$  represents the conditional probability density that an item of age  $t$  will fail (Ross, 1985 page 194). However, we can see from the definition the hazard function is the 'chance' of failure (though it is a normalized probability, not a probability) at time  $t$ , given that the individual has survived until time (<https://web.stat.tamu.edu/~suhasini/teaching613/chapter6.pdf>).

It is worth mentioning that it is probable as much as  $h(t) \times dt$  that a component with lifetime  $t$  will fail during the small interval  $dt$ , since

$$Pr(t < X < t + dt | X > t) = \frac{\int_t^{t+dt} f(t) dx}{R(t)} \cong \frac{f(t) dt}{R(t)} = h(t) dt$$

The importance of the hazard function is that it indicates the change in the failure rate over the life of a population of devices. For example, two designs may provide the same reliability at a specific time; however the failure rates up to this point in time can differ (K&L page 12).

The hazard function of a device is not necessarily the same in different lifetime intervals.

### 1-6-2 Necessary condition for being a hazard function

All hazard functions must satisfy two conditions (Ravindran, 2016 page 17-12). They cannot be negative

$$h(t) \geq 0 \quad \text{for all } t \geq 0 \quad (1-13-1)$$

and it could be proved that if a function  $h(t)$  is a hazard function then:

$$\int_0^{\infty} h(x) dx = \infty. \quad (1-13-2)$$

### 1-6-3 Hazard function and reliability function for discrete life time distributions

If a product life time( $X$ ) has a discrete distribution and  $P_X(k)$  is the probability that the product fails at time  $k$ , according to Eqs. 1-4 the reliability would be:

$$R(k) = \Pr(X \geq k) = \sum_{j=k}^{\infty} \Pr(X = j) = \sum_{j=k}^{\infty} P_X(j),$$

The function  $h(k)$  given below, is known as the rate function of "item with discrete lifetime distribution" (Xie et al, 2002):

$$h(k) = \Pr(X = k | X \geq k) = \Pr(X = k) / \Pr(X \geq k) \Rightarrow$$

$$h(k) = \frac{P_X(k)}{\sum_{j=k}^{\infty} P_X(j)} = \frac{P_X(k)}{R(k)}. \quad (14 - 1)$$

For example if the lifetime of an item has a Poisson distribution with parameter  $\lambda$ , then:

$$h(k) = \frac{P_X(k)}{R(k)} = \frac{P_X(k)}{\sum_{j=k}^{\infty} P_X(j)} = \frac{\lambda^k}{k! \sum_{x=k}^{\infty} \frac{\lambda^x}{x!}}$$

in MATLAB: 
$$h(k) = \frac{\text{poisspdf}(k, \text{landa})}{1 - \text{poisscdf}(k-1, \text{landa})}$$

### 1-6-4 Calculation of $h(t)$ , $R(t)$ , $F(t)$ , $f(t)$ given any of them

If any of the four functions  $h(t)$ ,  $R(t)$ ,  $F(t)$ ,  $f(t)$  are known, the other three are uniquely obtainable from it as described below (Grosh, 1989 page 16):

**$h(t)$  is known:**

$$h(t) = \frac{f(t)}{R(t)} \Rightarrow \frac{R'(t)}{R(t)} dt = -h(t) dt \Rightarrow \int_0^t \frac{R'(x)}{R(x)} dx = -\int_0^t h(x) dx$$

Assuming  $R(0) = 1$ , integrating yields, then

$$R(t) = e^{-\int_0^t h(\tau) d\tau} \quad (1-14-1)$$

$$f(t) = h(t)R(t) \quad (1-14-2)$$

$$F(t) = 1 - R(t) \quad (1-14-3)$$

**$f(t)$  is known:**

$$F(t) = \int_{-\infty}^t f(t) dt \quad R(t) = 1 - F(t) \quad h(t) = \frac{f(t)}{R(t)}$$

$$(1-15-1)$$

$$(1-15-2)$$

$$(1-15-3)$$

**F(t) is known:**

$$f(t) = \frac{d}{dt} F(t) \quad R(t) = 1 - F(t) \quad h(t) = \frac{f(t)}{R(t)}$$

(1-16-1)

(1-16-2)

(1-16-3)

**R(t) known**

$$h(t) = \frac{-R'(t)}{R(t)} \quad f(t) = h(t)R(t) \quad F(t) = 1 - R(t)$$

(1-17-1)

(1-17-2)

(1-17-3)

## 1-7 The pdf of a part of a distribution

If  $f(x)$ , the probability density function of a random variable is known, the density function of part (a b) of the random variable is:

$$f_{a-b}(x) = \frac{1}{\int_a^b f(x) dx} \times f(x) \quad (1-18)$$

## 1-8 Some continuous distributions used in reliability theory<sup>1</sup>

Below some useful probability distributions related to lifetime and reliability subject are reminded.

### 1-8-1 Exponential distribution

Exponential distribution is a distribution whose density function is

$$f(t) = \frac{1}{\theta} e^{-\frac{t}{\theta}}, \quad t \geq 0, \theta > 0 \quad \text{or} \quad = \lambda e^{-\lambda t} \quad \lambda > 0 \quad (1-19-1)$$

The reliability function related to this distribution is as follows:

$$R(t) = Pr(X > t) = \int_t^{\infty} \frac{1}{\theta} e^{-\frac{x}{\theta}} dx = e^{-\frac{t}{\theta}} \quad t \geq 0 \quad (1-19-2)$$

The hazard function is :

$$h(t) = \frac{f(t)}{R(t)} = \frac{1}{\theta} = \lambda \quad (1-19-3)$$

It is clear that the rate function of an exponential distribution is constant and independent of time. Conversely if we know the

---

<sup>1</sup> some softwares such as ARENA could determine the best distributions that fit a data set(e.g in ARENA tools-input analyzer- new-file data file- use existing- fit all)



failure rate of a random variable is time independent (constant), it is exponentially distributed.

It is worth mentioning that

-A gamma distribution with parameters  $(\alpha = 1, \beta)$  is an exponential distribution

-A Weibull distribution with parameters  $(A = 0, B, C = 1)$  is an exponential distribution

-The minimum of  $n$  independent exponential distributions with parameters  $\lambda_1, \dots, \lambda_n$  follows an exponential distribution with parameters  $\sum \lambda_i$ .

-According to Eq.1-18, the density function of a section of an exponential random variable say section  $(0, D)$  is:

$$\frac{\lambda e^{-\lambda x}}{1 - e^{-\lambda D}} \quad 0 < x < D.$$

### 1-8-2 Normal(Gaussian) distribution

The pdf of a normal distribution which is sometimes called Gaussian distribution is

$$f(x) = \frac{1}{\sigma\sqrt{2\pi}} e^{-\frac{(x-\mu)^2}{2\sigma^2}}, \quad -\infty < x < \infty \quad (1-20-1)$$

The rate function is:

$$h(t) = \frac{1}{\sigma\sqrt{2\pi}} \exp\left[-\frac{(t-\mu)^2}{2\sigma^2}\right] \left[1 - \Phi_z\left(\frac{t-\mu}{\sigma}\right)\right]^{-1} \quad (1-20-2)$$

where

$\Phi_Z$  is the cumulative distribution function(CDF) of standard normal.

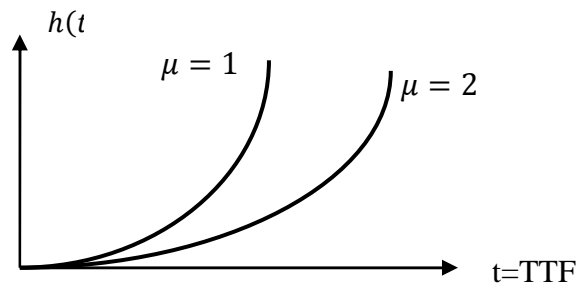

Fig. 1.1 shows the rate function of 2 normal distributions.

It is worth mentioning that normal distribution has the additive property i.e. if  $n$  independent normal distributions  $N(\mu_1, \sigma_1), \dots, N(\mu_n, \sigma_n)$  are added to give another random variable  $Y$ ,  $Y$  also follows a normal distribution,

### Example 1.3

Suppose the time to failure of a device is normally distributed with mean of 20000 cycles and standard deviation of 2000 cycles. Find the value of reliability(survivor) function and hazard function at 19000 cycles.

**Solution** Using Table D at the end of the book

$$R(19000) = \Pr(X > 19000) = \Pr\left(Z > \frac{19000 - 20000}{2000}\right) =$$

$$\Pr(Z > 0.5) = 1 - \Pr(Z < 0.5) = 0.69146 = 69.15\%$$

$$f(t) = \frac{1}{2000\sqrt{2\pi}} e^{-\frac{(t-2000)^2}{2(2000)^2}} \Rightarrow f(19000) = 0.000176$$

$$h(19000) = \frac{f(19000)}{R(19000)} = \frac{0.000176}{0.69146} = 0.000245 \text{ failures/cycle}$$

i.e. 245 failures per 1 million cycles. ▲

### 1-8-3 Truncated normal distribution( $\mu, \sigma; 0, \infty$ )

If we truncate the values of a normal distribution from below zero, the density function of the remaining values within the interval  $[0; \infty]$  would be derived from Eq. 1-18 as follows:

$$f(t) = \frac{1}{a\sigma\sqrt{2\pi}} e^{-\frac{1}{2}\left(\frac{t-\mu}{\sigma}\right)^2}, t \geq 0, \sigma > 0, -\infty < \mu < \infty \quad (1-21-1)$$

where

$$a = \int_0^{\infty} \frac{1}{\sigma\sqrt{2\pi}} e^{-\frac{1}{2}\left(\frac{t-\mu}{\sigma}\right)^2} dx = Pr\left(Z > \frac{-\mu}{\sigma}\right) = 1 - \Phi_Z\left(\frac{-\mu}{\sigma}\right)$$

Note that

-The probabilities of this distribution is not calculated in the same manner which is done in classical normal distributions.

- The mean and variance of this distribution does not equal  $\mu$  and  $\sigma^2$ . The mean is

$$E(X) = \mu + \frac{\sigma}{a} e^{-\frac{1}{2}\left(\frac{\mu}{\sigma}\right)^2} \quad (1-21-2)$$

This truncated distribution has an increasing rate function. Figure 1-2 shows the function for typical one plotted with the following MATLAB commands:

```
mu=3;sigma=0.1;t=0:.01:10;f=(normpdf(t,mu,sigma))/(normcdf(mu/si
gma))./(1-normcdf(t,mu,sigma));plot(t,f);
```

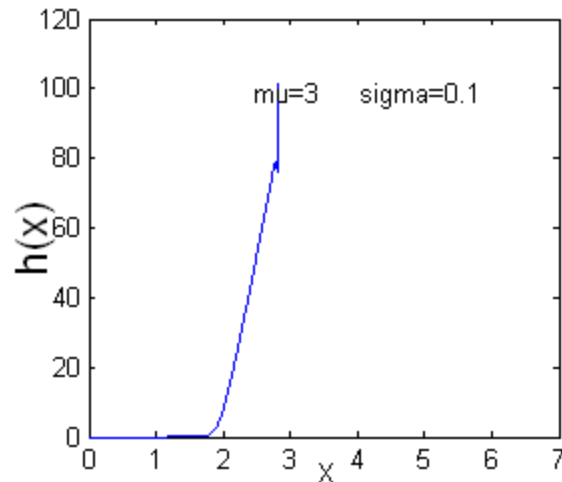

Fig. 1-2 Instantaneous rate function of a truncated with  $\mu = 3$  and  $\sigma = 0.1$   $X \geq 0$

#### 1-8-4 Log-normal distribution( $\mu, \sigma$ )

The probability density function of a log-normal distribution is:

$$f(t) = \frac{1}{\sigma t \sqrt{2\pi}} e^{-\frac{1}{2}\left(\frac{\ln t - \mu}{\sigma}\right)^2} \quad t \geq 0, \quad \sigma > 0 \quad -\infty < \mu < \infty \quad (1-22-1)$$

The mean, variance and median of the distribution is as follows:

$$E(T) = e^{\mu + \frac{\sigma^2}{2}} \quad (1-22-2)$$

$$\text{Var}(T) = (e^{2\mu+\sigma^2})(e^{\sigma^2} - 1) \quad (1-22-3)$$

$$\text{median}=e \quad (1-22-4)$$

Figure 1.3 shows the pdf of 2 sample lognormal distributions.

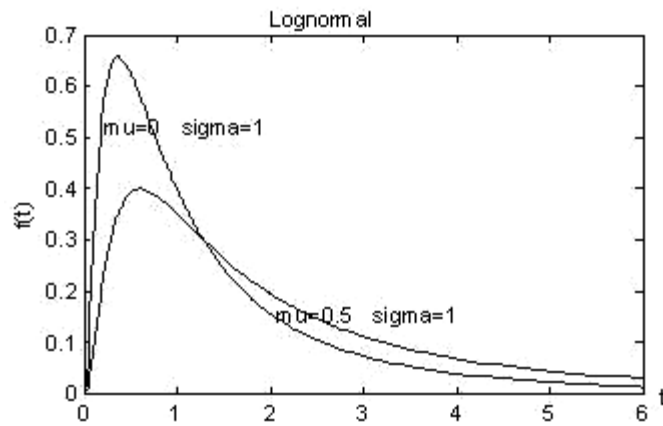

Fig. 1.3 The pdf of 2 lognormal distribution

#### 1-8-4-1 Calculation of the parameters( $\mu, \sigma$ ) of lognormal distribution from the mean and variance

Given  $E(T)$  and  $\text{Var}(T)$  as the mean and variance of a lognormal random variable, the parameters of the distribution is calculated from:

$$\sigma^2 = \ln \left[ \frac{\text{Var}(T)}{E^2(T)} + 1 \right], \quad (1-22-5)$$

$$\mu = \ln E(T) - \frac{\sigma^2}{2} . \quad (1-22-6)$$

#### 1-8-4-2 The relationship between lognormal ( $\mu, \sigma$ ) and normal ( $\mu, \sigma$ ) distributions

If  $T$  is distributed log-normally :  $T \sim \text{lognormal}(\mu, \sigma)$ , then  $X = \ln(T)$  is a normal random variable:  $\ln T \sim N(\mu, \sigma)$ .

If  $X$  is distributed normally :  $X \sim N(\mu, \sigma)$ , then  $T = e^X$  is a lognormal random variable:  $e^X \sim \text{logN}(\mu, \sigma)$ .

Fig. 1-4 compares the 2 distributions:

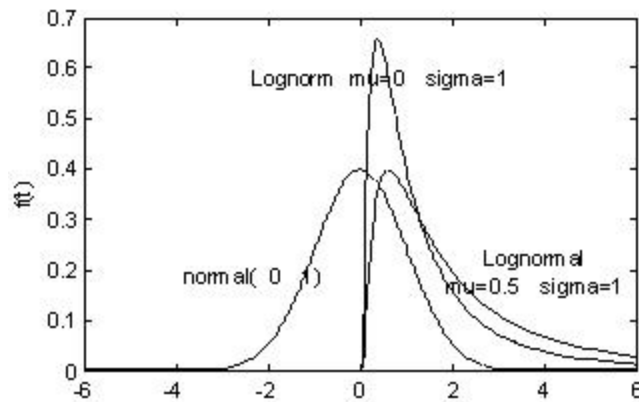

Fig 1.4 Normal and lognormal distributions

To calculate the probabilities in this distribution proceed as follows:

$$F_T(t) = \Pr(T < t) =$$

$$\Pr(\ln T < \ln t) = \Pr\left(\frac{\ln T - \mu}{\sigma} < \frac{\ln t - \mu}{\sigma}\right) = \Pr\left(Z < \frac{\ln t - \mu}{\sigma}\right)$$

$$\text{Then } F_T(t) = \phi_Z\left(\frac{\ln t - \mu}{\sigma}\right) \quad (1-22-7)$$

where  $\phi_Z$  is the CDF of standard normal.

The reliability function or survivor function is given by :

$$R(t) = Pr\left(Z > \frac{\ln t - \mu}{\sigma}\right) = 1 - \Phi_Z\left(\frac{\ln t - \mu}{\sigma}\right) \quad (1-22-8)$$

The command *lognormalcdf* from Table H at the end of the book might be used to calculate  $F_T(t)$  and  $R(T)$ :

$$F_T(t) = \text{lognormalcdf}(t, \mu, \sigma)$$

$$R(t) = 1 - \text{lognormalcdf}(t, \mu, \sigma)$$

The instantaneous failure rate function is:

$$h(t) = \frac{1}{\sigma \times t \sqrt{2\pi}} \frac{\exp\left[-\frac{(\ln t - \mu)^2}{2\sigma^2}\right]}{\left[1 - \Phi_Z\left(\frac{\ln t - \mu}{\sigma}\right)\right]} \quad (1-22-9)$$

In MATLAB,  $h(t)$  could be calculated by dividing commands *lognormalpdf* to  $1 - \text{lognormalcdf}$ : e.g.:

$$y = (\text{lognpdf}(x, 1, 2.5)) ./ (1 - \text{logncdf}(x, 1, 2.5)); \text{plot}(x, y)$$

Fig 1-5 shows the rate functions for 4 lognormal distributions.

This distribution seems to have little except its mathematical tractability to recommend itself as a failure distribution; it does seem to give good fit to repair time distributions (Barlow and Proschan, 1995 page 17).

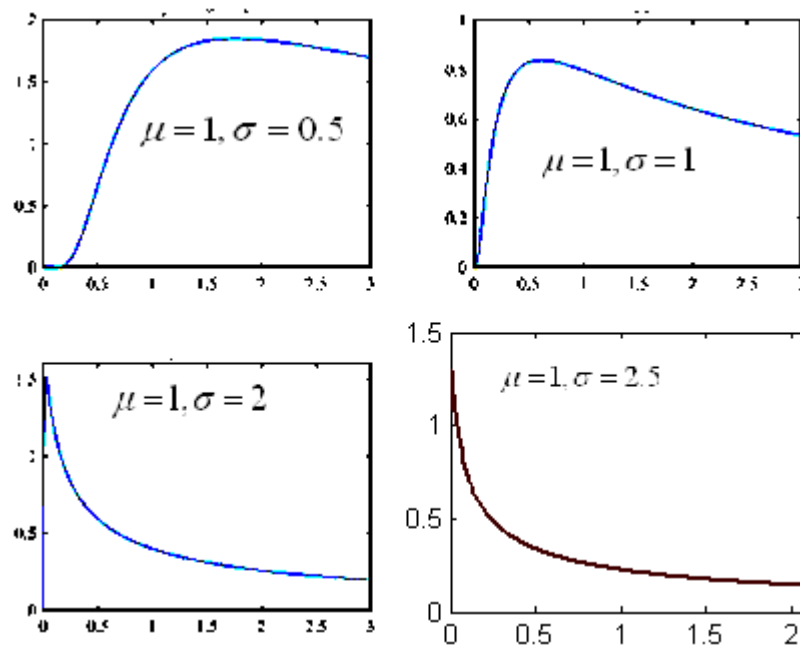

Fig 1-5 The hazard function for some lognormal variable with  $\mu = 1$  (the horizontal axis is the time and the vertical is the failure function)

### Example 1-4

If time to failure of a device is lognormally distributed with ( $\mu = 5, \sigma = 1$ ). Find the values of the reliability and hazard functions for  $t=150$  units of time.

### Solution

$$R(150) = Pr\left(Z > \frac{\ln 150 - 5}{1}\right) = 0.496$$

$$f_T(t) = \frac{1}{\sigma t \sqrt{2\pi}} e^{-\frac{1}{2}\left(\frac{\ln t - \mu}{\sigma}\right)^2}, \quad f_T(t = 150) \cong 0.0027$$



$$h(150) = \frac{f(150)}{R(150)} = \frac{0/0027}{0.496} = 0.0053 \text{ failure/1 unit time} =$$

$$53 \text{ failures/10000 units of time} \quad \blacktriangle$$

### 1-8-5 Uniform distribution

If the probability density function of a random variable is as follows:

$$f_X(x) = \begin{cases} \frac{1}{b-a} & a \leq x \leq b \\ 0 & \text{o.w} \end{cases} \quad (1-23-1)$$

The variable is said to be uniformly distributed over  $[a \ b]$ .

For example the density function of the uniform distribution in

$$\text{the interval } (0 \ \theta_0) \text{ is: } f(t) = \begin{cases} \frac{1}{\theta_0} & 0 \leq t \leq \theta_0 \\ 0 & \text{other} \end{cases}$$

In this distribution:

$$F_X(x) = \frac{x-a}{b-a} \quad (1-23-2)$$

$$R(x) = \frac{b-x}{b-a} \quad (1-23-3)$$

$$h(x) = \frac{f(x)}{R(x)} = \frac{1}{b-x} \quad a \leq x \leq b \quad (1-23-4)$$

Figures 1-6 and 1-7 shows the density function  $f(x)$  and the hazard function  $h(x)$ .

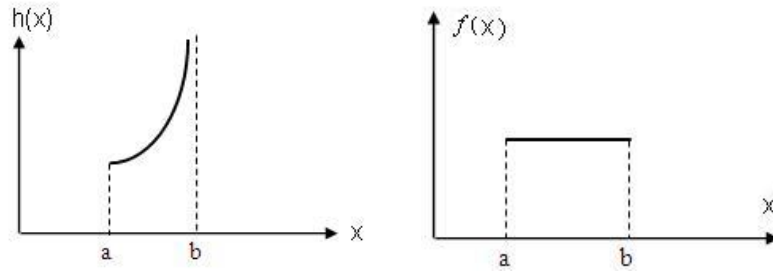

Fig 1.7 The hazard function of a uniform distribution      Fig 1.7 The density function of a uniform distribution

### 1-8-6 Weibull distribution

If the probability density function of a random variable is as follows:

$$f(t) = \frac{C}{B} \left( \frac{t-A}{B} \right)^{C-1} e^{-\left( \frac{t-A}{B} \right)^C} \quad t > A \quad (1-24-1)$$

This continuous distribution is called Weibull after Swedish mathematician and engineer Waloddi Weibull.

The CDF, the reliability (survivor) function, the rate function are:

$$F(t) = 1 - e^{-\left( \frac{t-A}{B} \right)^C} \quad (1-24-2)$$

$$R(t) = e^{-\left(\frac{t-A}{B}\right)^C} \quad (1-24-3)$$

$$h(t) = \frac{f(t)}{R(t)} = \frac{C}{B} \left(\frac{t-A}{B}\right)^{C-1} \quad (1-24-4)$$

and the mean, variance and median are:

$$E(T) = A + B \Gamma\left(1 + \frac{1}{C}\right) \quad (1-24-5)$$

$$\text{Var}(T) = B^2 \Gamma\left(1 + \frac{2}{C}\right) - B^2 \left(\Gamma\left(1 + \frac{1}{C}\right)\right)^2 \quad (1-24-6)$$

$$\text{median} = A + B (\ln 2)^{\frac{1}{C}} \quad (1-24-7)$$

A is called the location parameter, B is the scale parameter and C is the shape parameter.

An interpretation of location parameter in reliability theory :

A minimum life time of A is guaranteed.

Figure 1-8 shows some Weibull distribution pdf 's.

In weibull distribution:

-If  $A=0$  , the distribution is called 2-paramter distribution.

-If  $A=0$   $C=1$  , the distribution is exponential distribution whose hazard function is constant.

-If  $A=0$ ,  $C=2$  the distribution is called Rayleigh distribution whose hazard function is linear. This distribution is frequently used as the statistical distribution of sea wave height and to model the behavior of some communication channels.

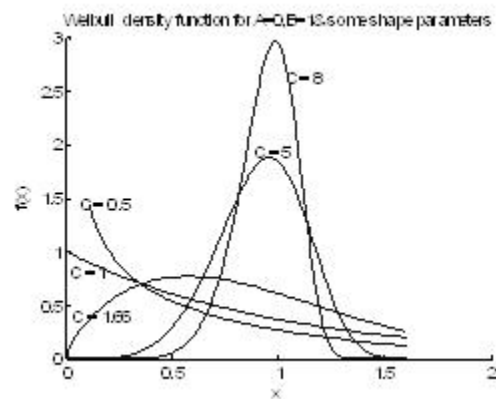

Fig. 1-8 Plot of the Weibull distribution for scale parameter  $B=1$  and five values of shape parameter (extracted from Grant&Leavenworth, 1988 page605)

Given a random sample  $x_1, \dots, x_n$ , the following relations could be used to estimate the parameters  $B$  and  $C$  of a Weibull distribution with  $A=0$ . These relations are related to maximum likelihood estimation (MLE) method in statistics theory.

$$C = \left[ \frac{\sum_{i=1}^n (x_i^C \ln x_i)}{\sum x_i^C} - \frac{\sum_{i=1}^n \ln x_i}{n} \right]^{-1} \quad (1-23-8)$$

$$B = \left[ \frac{\sum x_i^C}{n} \right]^{\frac{1}{C}} \quad (1-23-9)$$

- In an exceptional case where the shape parameter of Weibull (A,B,C) is C=3.44, the distribution could be approximated with a normal distribution with parameters (Carter,1986 as referenced by O'Connor, 2003 page 122 )

$$\mu = A + B\Gamma\left(1 + \frac{1}{C}\right) \cong A + 0.9B, \quad \sigma = B\sqrt{\Gamma\left(1 + \Gamma\left(\frac{2}{C}\right)\right)} \cong 0.3B$$

### Example 1-5

Write a MATLAB code to estimate the parameters B and C of a Weibull distribution from which the following random sample is at hand:

X=[113.0634 49.5432 53.4872 93.7147 74.0594  
114.3216 97.1033 61.5069 74.7216 52.8807];

Furthermore estimate the parameters with wblfit MATLAB command.

### Solution

```
%Sample X=[X(1).....X(n)]
X=[113.0634 49.5432 53.4872 93.7147 74.0594
114.3216 97.1033 61.5069 74.7216 52.8807];
for C=.01:0.001:40
for I=1:length(X)
LNX(I)=log(X(I));
XIC(I)=X(I)^C;XICLN(I)=XIC(I)*LNX(I);
end
A= C-(sum(XICLN)/sum(XIC)-sum(LNX)/length(X))^(1/C);
if ( abs(A)<= 0.001 ) C1=C; disp(sprintf('C= %6.4f ', C1))
end
end
B=(sum(X.^C1)/(length(X)))^(1/C1);
disp(sprintf('B= %6.4f ', B))
with MATLAB command wblfit:
```

```
>>wblfit(X)
ans = 87.1543 3.7149▲
```

### 1-8-7 GEV distribution

Fisher and Tippet presented three statistical distributions  $EV_1, EV_2, {}^1EV_3$ , or  $FT_1, FT_2, {}^2FT_3$ . Jerkinson (1955) showed that these 3 are special cases of one distribution which was called later generalized extreme value (GEV) distribution. The characteristics of this distribution as well as Weibull distribution and general Pareto distribution are given in Table F at the end of the book.

### 1-8-8 Gamma distribution

The gamma distribution is another continuous distribution used in reliability work to fit failure data. It is sufficiently flexible. A random variable X which follows a Gamma distribution has 2 positive parameter:  $\alpha > 0$   $\lambda > 0$  with the following pdf:

$$f(x) = \begin{cases} \frac{\lambda^\alpha}{\Gamma(\alpha)} x^{\alpha-1} e^{-\lambda x} & x > 0 \\ 0 & x \leq 0 \end{cases} \quad (1-24-1)$$

Furthermore:

---

<sup>1</sup> Extreme Value

<sup>2</sup> Fisher-Tippet I or Gumbel distribution

$$E(X) = \frac{\alpha}{\lambda} \quad (1-24-2)$$

$$\text{Var}(X) = \frac{\alpha}{\lambda^2} \quad (1-24-3)$$

$$\text{MGF}(t) = \left(\frac{\lambda}{\lambda - t}\right)^\alpha \quad (1-24-4)$$

$\alpha$  is called shape parameter and  $\lambda$  is the scale parameter.

The failure rate function of the gamma distribution does not exist in a simple closed form. Figure 1.9 shows the function.

For  $\alpha > 1$  it is increasing, for  $\alpha = 1$  it is constant and for  $\alpha < 1$  it is decreasing

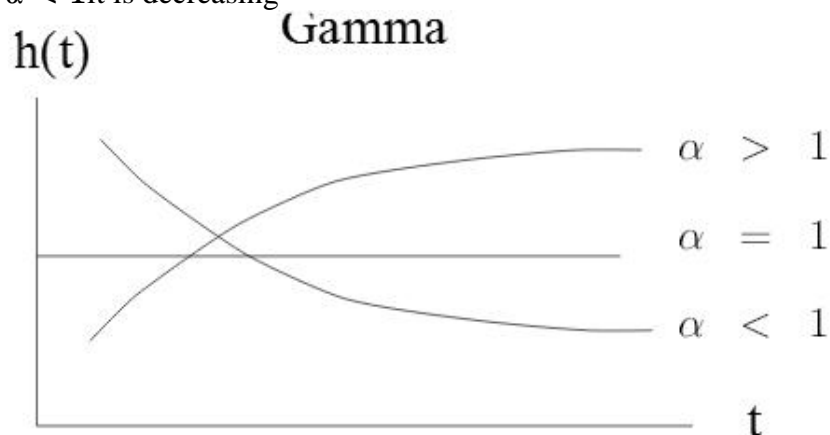

Fig 1-9 The hazard function of gamma distribution

#### 1-8-8-1 Erlang distribution

If  $\alpha$  is some positive integer  $n$ , the distribution is called Erlang and in the pdf we could replace  $\Gamma(n)$  with  $\Gamma(n) = (n - 1)!$ .

If  $\alpha = 1$  the distribution is exponential;

If  $\alpha = 2$  the distribution is Rayleigh.

An application of Erlang distribution is to calculate the probabilities related to the  $n^{\text{th}}$  occurrence in a Poisson process.

In Erlang distribution with parameters  $n$  and  $\lambda$  the  $k$ th moment about the origin is:

$$E(X^k) = \frac{\Gamma(n+k)}{\lambda^k \Gamma(n)} \quad n+k > 0 \quad (1-25)$$

Figure 1-10 shows three functions related to 7 different distributions.



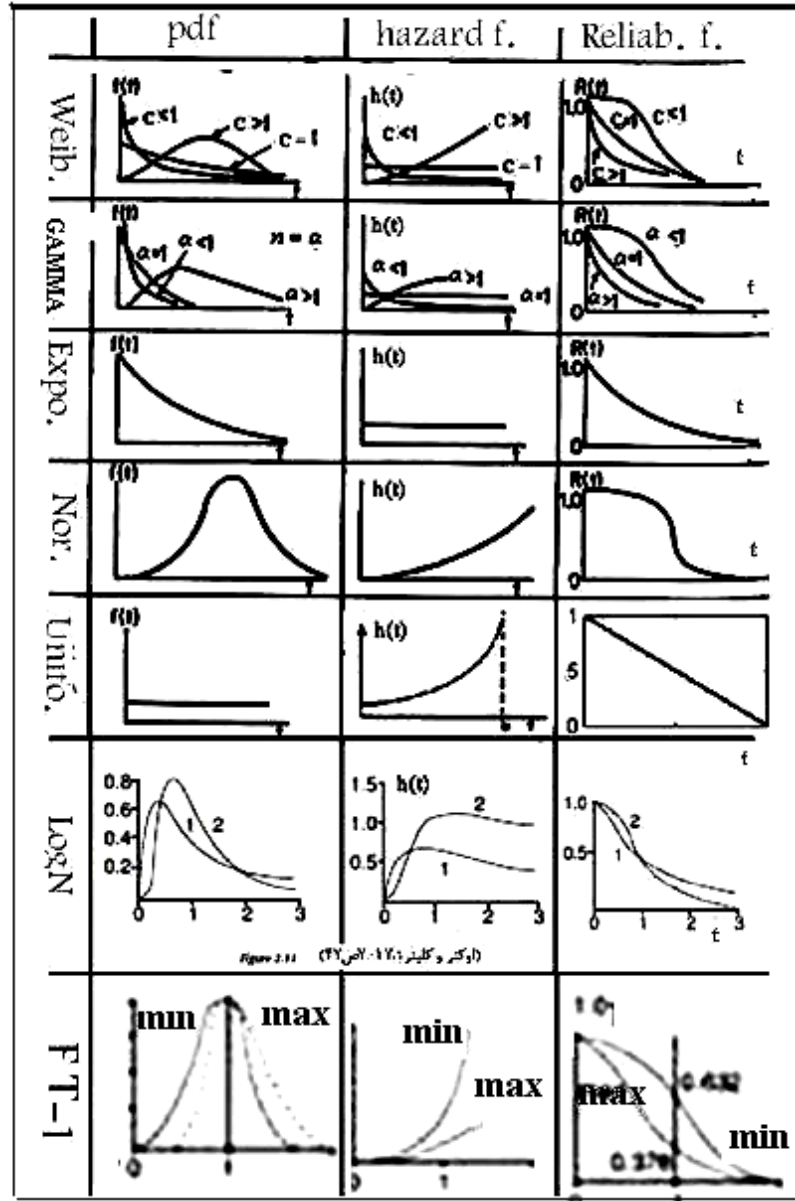

Fig. 1-10 pdf, h(t),R(t) of some distributions

### 1-9 Bathtub curve hazard function

The hazard function varies with time. A well-known pattern is called bathtub curve whose ideal form is shown in Fig.1-11-1.

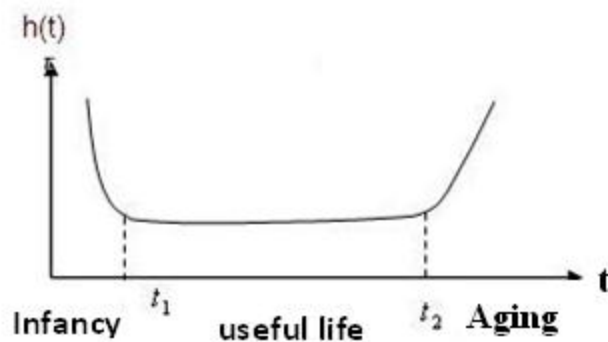

Fig 1-11-1 Ideal Bathtub curve

It comprises of three parts: 1)Infancy(early-life period ), 2)useful life, 3)aging. The first part represents the failure rate of early life period which is decreasing. The second part has a constant rate of failure, The last part is the wear-out period and has an increasing failure rate.

A distribution which could be used for each of the 3 parts of Fig.1-11-1 is Weibull distribution with different shape parameter  $C$  as described below:

$$\begin{cases} 0 < C < 1 & : & 0 < t < t_1 \\ C = 1 & & : & t_1 < t < t_2 \\ C > 1 & & : & t > t_2 \end{cases}$$

Figures 1-11-1 to 1-11-5 show some other variations of bathtub curve which happen in practice,

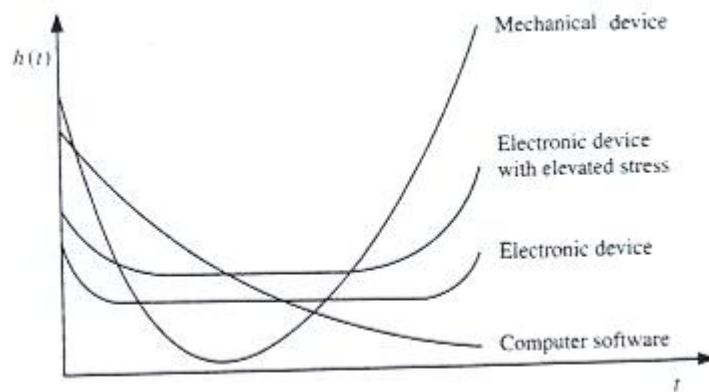

Fig 1-11-2 Some variations of bathtub curve(Kuo&Zuo,2003)

### BATHTUB CURVE

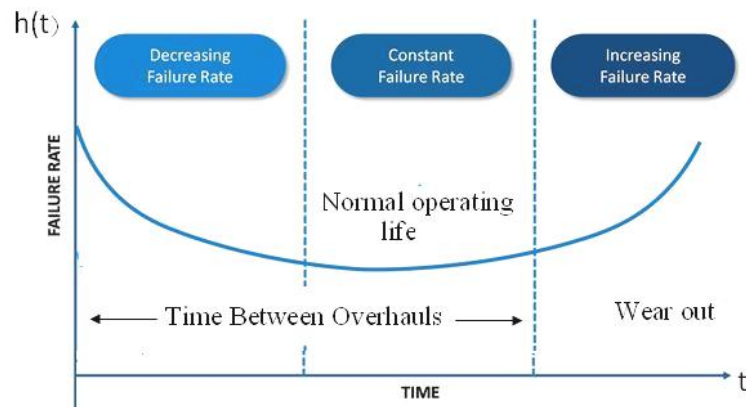

Fig 1-11-3 A variation of bathtub curve for some mechanical devices (Ireson,1995 page18-2)

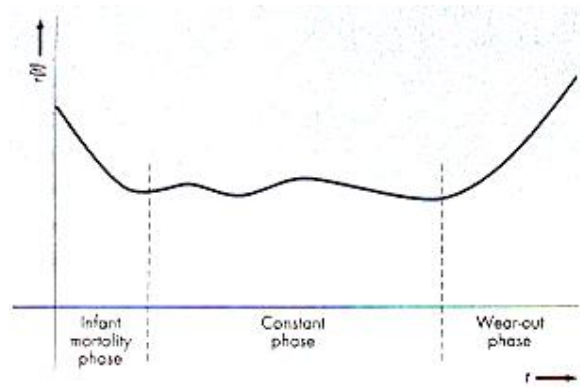

Fig 1-11-4 Another variation of Bathtub failure rate function  
(Nahmias, 2004, Fig.12-4)

Figure 1-11-5 shows different forms of bathtub failure curve due to different levels of stress on some mechanical devices.

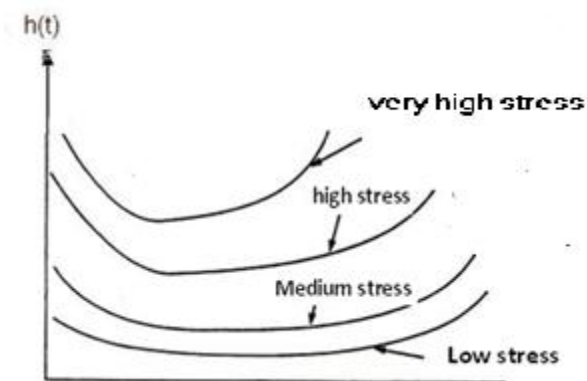

Fig1-11-5 Effects of stress levels on mechanical failure rates  
(Ireson,1995 Fig18-1, Stamatis,2010 Fig. 6-3 page163 )

### 1-9-1 Some forms of hazard functions

For each part of the bath tub curve different hazard function is appropriate. So next some kinds of failure rate function are considered (K&L page 28).

#### a- Constant hazard (failure rate) function

If the failure rate function is  $h(t) = \lambda$  i.e. is constant and does not depend on time, according to the relationship between the hazard function and the density function of lifetime (TTF);

$$f(t) = h(t)e^{-\int_0^t h(\tau)d\tau} = \lambda e^{-\int_0^t \lambda d\tau} = \lambda e^{-\lambda t} \quad \lambda > 0$$

$$R(t) = \frac{f(t)}{h(t)} = \frac{\lambda e^{-\lambda t}}{\lambda} = e^{-\lambda t}$$

Therefore if the **hazard function is constant**, the **lifetime is exponentially distributed**.

The concept of being constant is illustrated in the histogram and table of Example 1-11.

#### b- Linear hazard function

If the failure rate function is  $h(t) = \lambda + \alpha t$ ,  $\lambda \geq 0$  which represent a line, then

$$R(t) = e^{-\int_0^t h(\tau)d\tau} = e^{-\lambda t - \alpha \frac{t^2}{2}} \quad (1-26)$$

For the case  $\lambda = 0, \alpha > 0$ , the hazard function is linearly increasing:

$$h(t) = \alpha t \quad t \geq 0, \text{ The density function is}$$

$$f(t) = h(t)e^{-\int_0^t h(\tau)d\tau} \Rightarrow$$

$$f(t) = \alpha t e^{-\int_0^t c\tau d\tau} = \alpha t e^{-\alpha \frac{t^2}{2}} \quad t \geq 0 \quad (1-27-1)$$

Which corresponds a Rayleigh distribution or a Weibull distribution with parameters  $A=0, B=\sqrt{\frac{2}{\alpha}}, C=2$  whose reliability function is

$$R(t) = e^{-\alpha \frac{t^2}{2}} \quad (1-27-2)$$

For the case that the failure rate of a device is like a bathtub except the first and last part are linear, the hazard function is as follows (K&L page 29):

$$h(t) = \begin{cases} c_0 - c_1 t + \lambda & \lambda > 0, \quad 0 < t < \frac{c_0}{c_1} \\ \lambda & \lambda > 0, \quad \frac{c_0}{c_1} < t < t_0 \\ c(t - t_0) + \lambda & \lambda > 0, \quad t > t_0 \end{cases} \quad (1-28)$$

This hazard function linearly decreases to  $\lambda$  at time  $\frac{c_0}{c_1}$ , remains constant until time  $t_0$ , and then linearly increases.

### c- Power function Model

The hazard function might be of the following power function:

$$h(t) = \frac{Ct^{C-1}}{B^C} = \frac{C}{B} \left(\frac{t}{B}\right)^{C-1}$$

Then the density function and the reliability functions would be

$$f(t) = h(t)e^{-\int_0^t h(\tau)d\tau} = \frac{C}{B} \left(\frac{t}{B}\right)^{C-1} e^{-\left(\frac{t}{B}\right)^C} \quad C, B > 0$$

$$R(t) = e^{-\left(\frac{t}{B}\right)^C}$$

Which corresponds to a 2-parameter Weibull distribution

**d- Hazard function of form  $h(t) = \lambda + Ct^k$**

If the failure rate function is of the form  $h(t) = \lambda + Ct^k$

where  $C, k$  are constants then:

$$R(t) = e^{-\int_0^t h(\tau)d\tau} = e^{-\lambda t - C\frac{t^{k+1}}{k+1}}$$

**e- Hazard function of form  $h(t) = \gamma e^{\alpha t}$**

If the failure rate function is  $h(t) = \gamma e^{\alpha t}$  where  $\lambda, \gamma$  are constants, the function increase or decreases sharply and (K&L page 30):

$$f(t) = \gamma e^{\alpha t} e^{-\left(\frac{\gamma}{\alpha}\right)(e^{\alpha t}-1)} \quad (1-29-1)$$

The distribution is a kind of GEV distribution with the reliability function:

$$R(t) = e^{-\left(\frac{\gamma}{\alpha}\right)(e^{\alpha t}-1)} \quad (1-29-2)$$

## 1-10 Some discrete distributions

Below some discrete distributions are reminded.

### 1-10-1 Geometric distribution

Consider running an experiment(trial) which has two outcomes (failure or success). Let  $p$  = the probability of success in each trial. Now notice the two distributions described below:

#### a) Geometric distribution for failures

We perform the above experiment until a success occurs. Let  $X$  = the number of failures before the first success,

then the probability function of random variable  $X$  is given by:

$$P_X(x) = p(1 - p)^x. \quad 0 < p < 1, x = 0, 1, 2 \dots \quad (1 - 30 - 1)$$

The following figure shows the function for  $p = \frac{1}{36}$ .



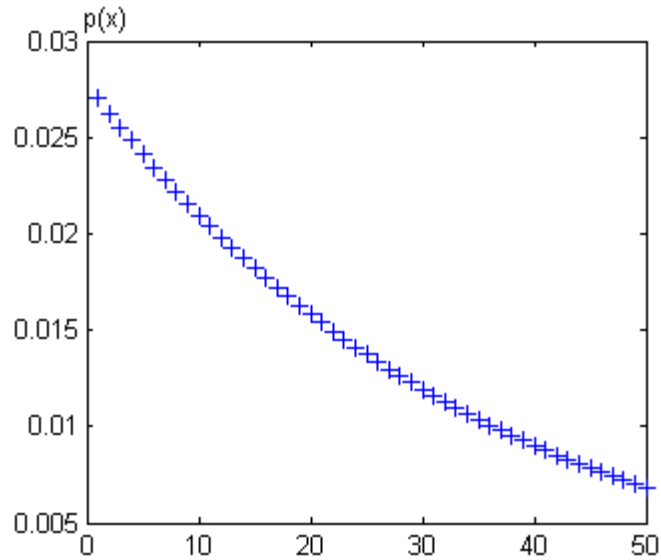

Fig. 1.12 The probability function of a Geometric distribution ( $p=0.1$ )

The CDF, the mean and the variance are:

$$F_X(x) = 1 - p(1 - p)^{x+1} \quad (1-30-2)$$

$$E(X) = \frac{1-p}{p} \quad (1-30-3) \quad \text{Var}(X) = \frac{1-p}{p^2} \quad (1-30-4)$$

In this distribution the hazard function is constant:

$$h(x) = p \quad (1 - 30 - 5)$$

### **b) Geometric distribution for success**

If We perform the above experiment until the first success occurs and define a random variable

$X$  = the number of trials until the first success, and

then the probability function of random variable  $X$  is given by:

$$P_X(x) = p(1 - p)^{x-1}, \quad 0 < p < 1, \quad x = 1, 2, \dots \quad (1-31-1)$$

and

$$E(X) = \frac{1}{p} \quad (1-31-2) \quad \text{Var}(X) = \frac{1-p}{p^2} \quad (1-31-3)$$

Geometric distribution is the only discrete distribution which is memory-less.

### 1-10-2 Binomial distribution

If the probability function of a random variable  $x$  with binomial distribution which has 2 parameters positive integer  $n$ ,  $0 < p < 1$  is as follows:

$$P_X(x) = \binom{n}{x} p^x (1 - p)^{n-x}, \quad x = 0, 1, \dots \quad (1-32-1)$$

As proved in Example 1-6 the mean of binomial distribution is

$$E(x) = np. \quad (1-32-2)$$

The variance is

$$\text{Var}(X) = np(1-p). \quad (1-32-3)$$

#### Example 1-6

Find the mean of a binomial distribution .

**Solution**

$$E(X) = \sum_{x=0}^n x \binom{n}{x} p^x (1-p)^{n-x}$$

Since the value of the first term (i.e. for  $x=0$ ) is zero and

$$i \binom{k}{i} = k \binom{k-1}{i-1} \text{ then}$$

$$E(X) = \sum_{x=0}^n x \binom{n}{x} p^x (1-p)^{n-x} = \sum_{x=1}^n n \binom{n-1}{x-1} p^x (1-p)^{n-x} = np \sum_{x=1}^n \binom{n-1}{x-1} p^{x-1} (1-p)^{n-x}$$

$$x-1=y \Rightarrow E(X) = np \sum_{y=0}^{n-1} \binom{n-1}{y} p^y (1-p)^{n-1-y}$$

$$(a+b)^n = \sum_{i=0}^n \binom{n}{i} a^i b^{n-i} \Rightarrow E(X) = np(p+1-p)^{n-1} = np$$

For The binomial distribution with parameters  $\sim B(k, \pi)$  :

$$E(X) = k\pi .$$

End of Example 

**1-10-2 Poisson distribution**

The Poisson distribution gives the probability of a given number of events happening in a specified time period.

If we let  $X$  = the number of events in a unit time, then the probability function is given by:

$$P_X(x) = \frac{\lambda^x (e^{-\lambda})}{x!} \quad \lambda > 0 \quad x = 0, 1, 2, \dots \quad (1-33-1)$$

and

$$\text{Var}(X)=E(X)=\lambda \quad (1-33-2)$$

Therefore it could be concluded that if the mean and variance of a random variable are not equal, its distribution is not Poisson.

Now let  $X$  = the number of events in a time interval and

$\lambda$  = the average number of events occurring in a unit time interval then the probability function is given by:

$$P_X(x) = \frac{(\lambda t)^x (e^{-\lambda t})}{x!} \quad x = 0, 1, 2, \dots \quad (1-33-3)$$

and

$$\text{Var}(X)=E(X)=\lambda t \quad (1-33-4)$$

In fact  $t$  could be expressed in other units (length unit, space unit...) as well as time unit (Ireson et al, 1996).

**Example 1-7** (Ireson et al, 1996page 11-26).

The failure of an electricity transfer line has roughly a Poisson distribution with annual mean of 0.0256 failure per 1000 feet(nearly 26 failures per one million feet). Find the probability that no failures occurs along 515.8 feet of the line.

**Solution**

$$\lambda = 0.0256$$

Let  $X$  = the number failures occurring along  $t$  feet.

For  $t=515.8$  feet, the desired probability is

$$\Pr(X=0) = \frac{(0.0256 \times 515.8)^0 e^{-0.0256 \times 515.8}}{0!} = 1.8 \times 10^{-6} \blacktriangle$$

The following table shows the probability function, the CDF, the hazard function of some discrete probability distributions.

Distribution	$Pr(x = x)$	$Pr(x \leq x)$	$h(x)$
Discrete uniform $x \in \{0, 1, \dots, n\}$	$\frac{1}{n}$	$\frac{x+1}{n}$	$\frac{x}{n-x}$
<b>Binomial</b> $x \in \{0, 1, \dots, n\}$	$\binom{n}{x} p^x (1-p)^{n-x}$	$\sum_{k=0}^x \binom{n}{k} p^k (1-p)^{n-k}$	$\frac{\binom{n}{x} p^x (1-p)^{n-x}}{\sum_{k=x}^n \binom{n}{k} p^k (1-p)^{n-k}}$
Poisson $x \in \{0, 1, \dots\}$	$\frac{\lambda^x e^{-\lambda}}{x!}$	$e^{-\lambda} \sum_{k=0}^x \frac{\lambda^k}{k!}$	$\frac{\lambda^x}{x! \left(1 - \sum_{k=0}^{x-1} \frac{\lambda^k}{k!}\right)}$
Geometric $x \in \{0, 1, \dots\}$	$p(1-p)^x$	$1 - (1-p)^{x+1}$	$p$
Hyper-geometric $\max(0, m+n-N) \leq x \leq \min(n, m)$	$\frac{\binom{m}{x} \binom{N-m}{n-x}}{\binom{N}{n}}$	$\sum_{k=0}^x \frac{\binom{m}{k} \binom{N-m}{n-k}}{\binom{N}{n}}$	$\frac{x \binom{m}{x} \binom{N-m}{n-x}}{\sum_{k=x}^{\min(m,n)} \binom{m}{k} \binom{N-m}{n-k}}$

## **1-11 On accelerated life testing (ALT), parametric and non-parametric reliability analysis**

In reliability theory, to speed out obtaining life data for a kind of device, system or component there are some tests called accelerated life testing and to estimate the values related to reliability of a device, system or component there are 2 methods: parametric and nonparametric. These concepts are briefly described below.

### **1-11-1 Accelerated life testing(ALT)**

To perform reliability analysis for a device ,system or a component the analyst needs life data. In conventional life testing, to obtain life data some devices are set on a test under normal condition until they fail. Obtaining life data in this way is very time consuming and sometimes impossible. Accelerated life testing (ALT) is the process of testing a product by subjecting it to conditions (stress, strain, temperatures, voltage, vibration rate, pressure etc.) in excess of its normal service. The life test data is extrapolated to obtain the estimates of normal time to failure. ALT produces the required data in a short amount of time. Tobias & Trindad(2019) and Cabarbaye(2019) are 2 references among many others which deal with ALT.

### **1-11-2 Parametric reliability analysis**

In parametric models of reliability analysis, a statistical distribution such as exponential, Weibull, lognormal and normal is used to fit the life data or failure rate to estimate the values such as reliability, failure rate of components.

### **1-11-3 Non-parametric reliability analysis**

Nonparametric analysis allows the analyst to characterize life data without assuming an underlying distribution. There are some methods in this kind of analysis including Kaplan–Meier method, simple actuarial method and standard actuarial method. Below nonparametric estimation of functions  $\mathbf{h(t)}$ ,  $\mathbf{R(t)}$ ,  $\mathbf{F(t)}$ ,  $\mathbf{f(t)}$  from grouped observations and from ordered sample is described.

#### **1-11-3-1 Non-parametric Estimation of $\mathbf{h(t)}$ , $\mathbf{R(t)}$ , $\mathbf{F(t)}$ , $\mathbf{f(t)}$ from Grouped Observations**

Below it is described how the functions  $\mathbf{h(t)}$ ,  $\mathbf{R(t)}$ ,  $\mathbf{F(t)}$ ,  $\mathbf{f(t)}$  for a product could be estimated from a frequency distribution table of grouped lifetimes or from a random sample of lifetime

### 1-11-3-2 Non-parametric Estimation of $h(t)$ , $R(t)$ , $F(t)$ , $f(t)$ from frequency table

Suppose the following frequency distribution table has been prepared from a random sample of size  $N_0$  put on test for the lifetime of an item :

interval	$(a_1 \ b_1)$	$(a_2 \ b_2)$	...	$(a_i \ b_i)$	..	$(a_n \ b_n)$	sum
Frequ.	$f_1$	$f_2$	..	$f_i$	..	$f_n$	$N_0$

and let

$N_0$  The size of the initial sample put on lifetime test at  $t=0$

$\bar{N}(t)$  The number of survivor components (or the number still working adequately) at time  $t$

Given the above frequency table, the four functions could be estimated as follows:

#### The reliability function estimate

The reliability function at  $t = b_i$  is estimated as:

$$\hat{R}(b_i) = \frac{\bar{N}(b_i)}{N_0} \quad (1-34)$$



### The hazard function estimate

The hazard function related to  $i^{\text{th}}$  interval i.e.  $a_i - b_i$  could be estimated as follows (K&L page 13 Grosh, 1989 page 3):

$$\hat{h}(t) = \frac{\bar{N}(a_i) - \bar{N}(b_i)}{\bar{N}(a_i) \times (b_i - a_i)} = \frac{\text{number of items failed during } (\Delta t)_i}{\bar{N}(a_i) \times (\Delta t)_i} \quad (1-35-1)$$

If during  $(\Delta t)_i = b_i - a_i$  one item fails then

$$\hat{h}(t) = \frac{1}{\bar{N}(a_i) \times (\Delta t)_i} \quad (1-35-2)$$

### The density function estimate

The density function for  $a_i < t < b_i$  is estimated as follows:

$$\hat{f}(t) = \frac{\bar{N}(a_i) - \bar{N}(b_i)}{N_0 \times (b_i - a_i)} = \frac{\text{number of items failed during } (\Delta t)_i}{(\text{initial sample size}) \times (\Delta t)_i} \quad (1-36)$$

### The cumulative distribution function (CDF) estimate

The CDF at  $t = b_i$  is estimated from:

$$\hat{F}(b_i) = 1 - \hat{R}(b_i) = 1 - \frac{\bar{N}(b_i)}{N_0} \quad (1-37)$$

### Example 1-8

46 components were placed on a life test. The system is observed every 20000 hours and number survivors are written down (see the following frequency distribution table). Estimate  $h(t)$ ,  $R(t)$ ,  $F(t)$ ,  $f(t)$ .

Time intervals(hr)	failures in interval	Cum. frequ.	$\bar{N}(t)$ =the number of components working at Time t
0-20000	19	19	27
20000 <sup>+</sup> -40000	11	30	16
40000 <sup>+</sup> -60000	7	37	9
60000 <sup>+</sup> -80000	5	42	4
80000 <sup>+</sup> -190000	4	46	0
>100000	0	46	0
Sum	$N_0 = 46$		

**Solution**

The above relationships were used to estimate  $h(t), R(t), F(t), f(t)$ . The results are shown in the following table:

i	$a_i$	$b_i = a_i + (\Delta t)_i$	$\bar{N}(a_i)$	$\bar{N}(b_i)$	$\hat{R}(b_i) = \frac{\bar{N}(b_i)}{N_0}$	$\hat{F}(b_i)$	$\hat{f}(t)$ multiply by: $10^{-3}$	$\hat{h}(t)$ multiply by: $10^{-4}$
							$a_i < t < b_i$	
1	0	20000	46	27	0.587	0.413	0.207	0.207
2	20000	40000	27	16	0.348	0.652	0.120	0.204
3	40000	60000	16	9	0.196	0.804	0.076	0.219
4	60000	80000	9	4	0.087	0.913	0.055	0.278
5	80000	100000	4	0	0.0	1.000	0.044	0.500

To see how the estimates were calculated, Sample calculations are shown below:

$$\hat{R}(b_1) = \frac{N(b_1)}{N_0} \rightarrow \hat{R}(20000) = \frac{\bar{N}(20000)}{N_0} = \frac{46 - 19}{46} = \frac{27}{46} = 0.587$$

$$\hat{h}(t) = \frac{\bar{N}(a_i) - \bar{N}(b_i)}{\bar{N}(a_i) (b_i - a_i)} \rightarrow$$

$$\hat{h}(t) = \frac{46 - 27}{(46)(20000)} = 0.207 \times 10^{-4} \quad 0 < t \leq 20000$$

$$\hat{f}(t) = \frac{\bar{N}(a_i) - \bar{N}(b_i)}{N_0 \times (b_i - a_i)} \rightarrow$$

$$20000 < t \leq 40000 \quad \hat{f}(t) = \frac{27 - 16}{(46)(20000)} = 0.12 \times 10^{-3} \quad \blacktriangle$$

### Example 1-9

10 components were placed on life test. If one failure has occurred in each of the time intervals given in the following table estimate and plot the density function, the reliability function and hazard function for the time intervals. (Grosh.,1989 Example 1.1 )

### Solution

Note that for all intervals  $f_i = 1$ . Therefore according to Eqs. 1-34 through 1-37:

$$\hat{f}(t) = \frac{1}{N_0 \times (b_i - a_i)}, \hat{R}(b_i) = \frac{\bar{N}(b_i)}{N_0}, \hat{h}(t) = \frac{1}{\bar{N}(a_i) (b_i - a_i)}$$

The following table and figures shows the results of the calculations based on these equations.

i			$\hat{f}(t) = \frac{1}{N_0(b_i - a_i)}$ $a_i < t < b_i$ ( $\times 0.01$ )	$\hat{R}(b_i)$ $=$ $\frac{\bar{N}(b_i)}{N_0}$	$\hat{h}(t) = \frac{1}{\bar{N}(a_i)(b_i - a_i)}$ <i>for</i> $a_i < t < b_i$ ( $\times 0.01$ )
	$a_i$	$b_i$			
1	0	5	$1/(10*5)= 2$	$\frac{9}{10}$	$1/(10*5)= 2$
2	5+	10	$1/(10*5)=2$	$\frac{8}{10}$	$1/(9*5)= 2.22$
3	10+	17.5	$1/(10*7.5)= 1.33$	$\frac{7}{10}$	$1/(8*7.5)= 1.67$
4	17.5+	30	$1/(10*12.5)=0.$	$\frac{6}{10}$	$1/(7*12.5)= 1.14$
5	30+	40	$1/(10*10)= 1$	$\frac{5}{10}$	$1/(6*10)= 1.67$
6	40+	55	$1/(10*15)=0. 67$	$\frac{4}{10}$	$1/(5*15)= 1.33$
7	55+	67.5	$1/(10*12.5)=0. 8$	$\frac{3}{10}$	$1/(4*12.5)= 2$
8	67.5+	82.5	$1/(10*15)=0. 67$	$\frac{2}{10}$	$1/(3*15)= 2.22$
9	82.5+	100	$1/(10*17.5)=0.$	$\frac{1}{10}$	$1/(2*17.5)= 2.86$
10	100+	117.5	$1/(10*17.5)=0.$	0	$1/(1*17.5)= 5.7$

The following figures shows the functions of Example 1-9:

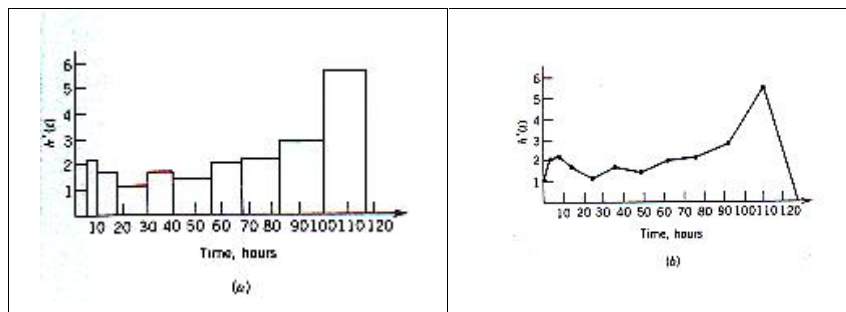

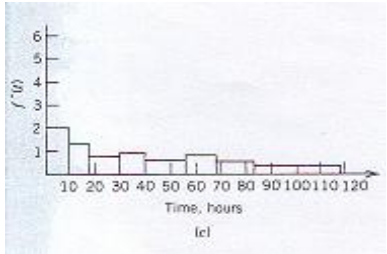
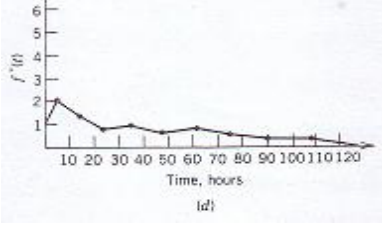
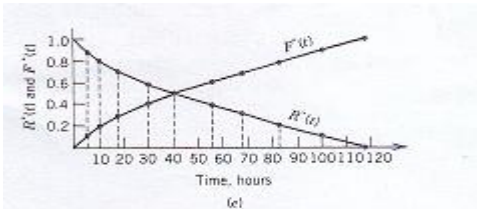
Histogram of failure rate	Polygon of failure rate
	
Histogram of density function	Polygon of density function
	
Cumulative density function and Reliability function	

### Example 1-10

800 units of a product were placed on the life test and every 3 hours the number of failures were recorded (see table below). Estimate and plot the density function, the reliability function & hazard function for the time intervals. (Example. 1.2 Grosh, 1989 )

### Solution

The appropriate equations are:

$$\hat{f}(t) = \frac{f_i}{N_0(b_i - a_i)} \quad , \quad \hat{R}(b_i) = \frac{\bar{N}(b_i)}{N_0} \quad , \quad \hat{h}(t) = \frac{f_i}{\bar{N}(a_i)(b_i - a_i)}$$

The following table and figures shows the results of the Calculations:

Calculations of Example 1-10						
i	$a_i$	$b_i$	no. of failures	Density function $f^{\wedge}(t) = \frac{f_i}{N_0(b_i - a_i)}$ $a_i < t < b_i$	$\hat{R}(b_i) = \frac{\bar{N}(b_i)}{N_0}$	Failure rate $\hat{h}(t) = \frac{f_i}{\bar{N}(a_i)(b_i - a_i)}$ $a_i < t < b_i$
1	0	3	185	$185/(800 \times 3) = 0.0771$	$\frac{615}{800}$	$185/(800 \times 3) = 0.0771$
2	3	6	42	$42/(800 \times 3) = 0.0175$	$\frac{573}{800}$	$42/(615 \times 3) = 0.0227$
3	6	9	36	$36/(800 \times 3) = 0.015$	$\frac{537}{800}$	$36/(573 \times 3) = 0.0209$
4	9	12	30	$30/(800 \times 3) = 0.0125$	$\frac{507}{800}$	$30/(537 \times 3) = 0.0175$
5	12	15	17	$17/(800 \times 3) = 0.0071$	$\frac{490}{800}$	$17/(507 \times 3) = 0.0112$
6	15	18	8	$8/(800 \times 3) = 0.0033$	$\frac{482}{800}$	$8/(490 \times 3) = 0.0054$
7	18	21	14	$14/(800 \times 3) = 0.0058$	$\frac{468}{800}$	$14/(482 \times 3) = 0.0097$
8	21	24	9	$9/(800 \times 3) = 0.00375$	$\frac{459}{800}$	$9/(468 \times 3) = 0.0064$
9	24	27	6	$6/(800 \times 3) = 0.0025$	$\frac{453}{800}$	$6/(459 \times 3) = 0.0044$
10	27	30	3	$3/(800 \times 3) = 0.0013$	$\frac{450}{800}$	$3/(453 \times 3) = 0.0022$

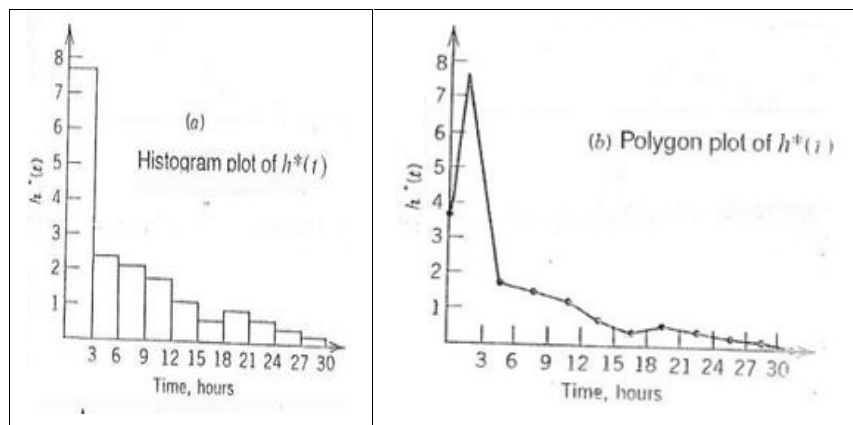

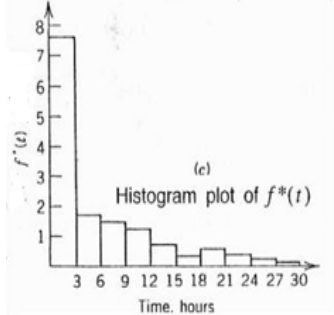
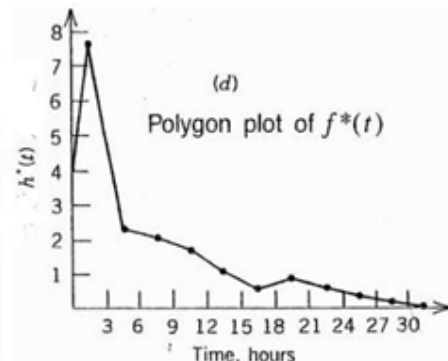
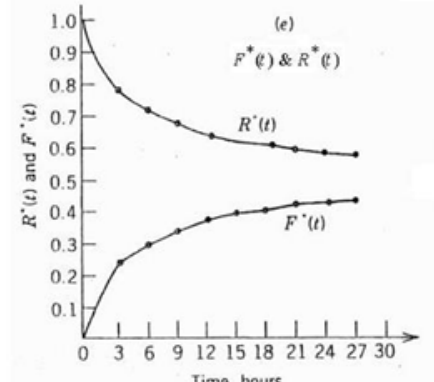
Histogram of failure rate	Polygon of failure rate
 <p>(c) Histogram plot of <math>f^*(t)</math></p>	 <p>(d) Polygon plot of <math>f^*(t)</math></p>
<p>Histogram of density function</p>	<p>Polygon of density function</p>
 <p>(e) <math>F^*(t)</math> &amp; <math>R^*(t)</math></p>	<p>Cumulative Distr. function and Reliability function</p>
<p>The functions of Example 1-10 (Grosh, 1989 Example 1.2)</p>	

### Example 1-11

Estimate the density function, the reliability function and the rate function related to a product whose life test results for 200 units are shown on the following histogram.

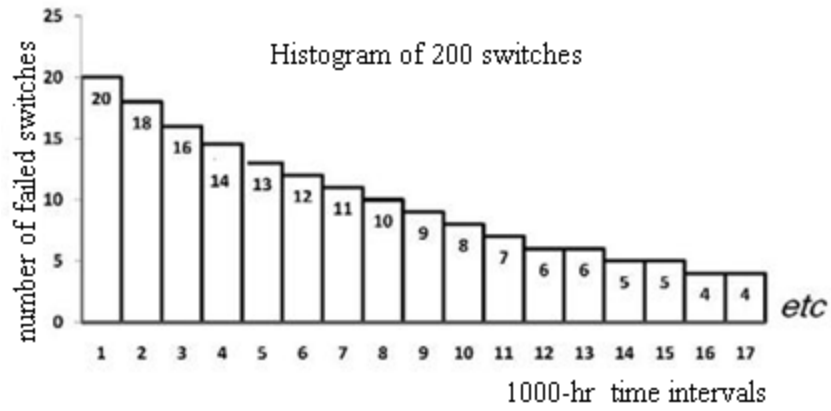

Fig. 1-13 Histogram of 200 Switch lifetimes (Feigenbaum,1990)

**Solution**

$\hat{h}(t)$ ,  $\hat{f}(t)$ ,  $\hat{R}(t)$  were calculated using Eqs. 1-35-1, 1-36-1 and 1-37. The following table shows the results:

Estimation of $h(t)$ , $R(t)$ , $F(t)$ , $f(t)$ for the lifetime of the switches in Histogram of Fig 1-12												
1000-hr interval	1	2	3	4	5	6	7	8	9	10	11	12
Items volume working at the beginning of the interval	200	180	162	146	132	119	107	96	86	77	69	62
Failure frequency	20	18	16	14	13	12	11	10	9	8	7	6
No. of Failures in the interval $h(t) \cong 0.1$	$\frac{20}{200} = 0.1$	$\frac{18}{180} = 0.1$	$\frac{16}{162} \cong 0.098$	$\frac{14}{146}$	0.1	$\frac{12}{119}$	$\frac{11}{107}$	$\frac{10}{96}$	$\frac{9}{86}$	$\frac{8}{77}$	$\frac{7}{69}$	$\frac{6}{62}$



<b>Estimation of <math>h(t), R(t), F(t), f(t)</math> for the lifetime of the switches in Histogram of Fig 1-12</b>												
1000-hr interval	1	2	3	4	5	6	7	8	9	10	11	12
Items volume working at the beginning of the interval	200	180	162	146	132	119	107	96	86	77	69	62
Failure frequency	20	18	16	14	13	12	11	10	9	8	7	6
No. of Failures in the interval $h(t) \cong 0.1$	$\frac{20}{200} = 0.1$	$\frac{18}{180} = 0.1$	$\frac{16}{162} \cong 0.098$	$\frac{14}{146}$	0.1	$\frac{12}{119}$	$\frac{11}{107}$	$\frac{10}{96}$	$\frac{9}{86}$	$\frac{8}{77}$	$\frac{7}{69}$	$\frac{6}{62}$
$D = 2 \times 10^5$ $\hat{f}(t)$ t in hour	$\frac{20}{D}$	$\frac{18}{D}$	$\frac{16}{D}$	$\frac{14}{D}$	$\frac{13}{D}$	$\frac{12}{D}$	$\frac{11}{D}$	$\frac{10}{D}$	$\frac{9}{D}$	$\frac{8}{D}$	$\frac{7}{D}$	$\frac{6}{D}$
$\hat{f}(t)$ t in 1000 hours	$\frac{20}{200}$	$\frac{18}{200}$	$\frac{16}{200}$	$\frac{14}{200}$	$\frac{13}{200}$	$\frac{12}{200}$	$\frac{11}{200}$	$\frac{10}{200}$	$\frac{9}{200}$	$\frac{8}{200}$	$\frac{7}{200}$	$\frac{6}{200}$
$\hat{F}(t)$ t in 1000 hours	$\frac{20}{200}$	$\frac{38}{200}$	$\frac{54}{200}$	$\frac{68}{200}$	$\frac{81}{200}$	$\frac{93}{200}$	$\frac{104}{200}$	$\frac{114}{200}$	$\frac{123}{200}$	$\frac{131}{200}$	$\frac{138}{200}$	$\frac{144}{200}$
$\hat{R}(t)=1-\hat{F}(t)$	0.90	$\frac{0.8}{1}$	0.73	0.66	0.6	.54	.48	0.43	0.39	.36	.48	0.28

End of Example ▲

### 1-11-2 Estimation of $h(t), R(t), F(t), f(t)$ from ordered random sample

Suppose a random sample of  $n$  units of a product were placed on life test and the  $n$  failure time are :

$$t_{(1)} < t_{(i)} < \dots < t_{(n)}.$$

$h(t), R(t), F(t), f(t)$  could be estimated similar to Example 1-8 by forming subintervals with frequency 1. However at the  $i^{\text{th}}$  ordered time i.e.  $t_{(i)}$ , they could be estimated from the following relations as well( K&L p 32):

$$\hat{F}(t_{(i)}) = \frac{i-0.3}{n+0.4} \quad (1-38)$$

$$\hat{R}(t_{(i)}) = 1 - \frac{i-0.3}{n+0.4} \quad (1-39)$$

$$\hat{h}(t_{(i)}) = \frac{\hat{R}(t_{(i)}) - \hat{R}(t_{(i+1)})}{(t_{(i+1)} - t_{(i)})[\hat{R}(t_{(i)})]} \Rightarrow$$

$$\hat{h}(t_{(i)}) = \frac{1}{(t_{(i+1)} - t_{(i)})(n-i+0.7)} \quad (1-40)$$

$$\hat{f}(t_{(i)}) = \frac{\hat{F}(t_{(i+1)}) - \hat{F}(t_{(i)})}{t_{(i+1)} - t_{(i)}} \Rightarrow$$

$$\hat{f}(t_{(i)}) = \frac{1}{(t_{(i+1)} - t_{(i)})(n+0.4)} \quad (1-41)$$

#### Example 1-12

8 units of a kind of spring were placed on the life test. The spring failed at the following kilo cycles:

190, 245, 265, 300, 320, 325, 370, 400

Estimate  $F(t)$ ,  $R(t)$ ,  $f(t)$  and  $h(t)$  at the above points in time.

### Solution

The computations are shown in the following table.

Failure No.(i)	$t = t_{(i)}$	$\hat{F}(t)$	$\hat{R}(t)$	$\hat{f}(t)$	$\hat{h}(t)$
1	190	0.083	0.917	0.0022	0.0024
2	245	0.202	0.798	0.0060	0.0075
3	265	0.321	0.679	0.0034	0.0050
4	300	0.440	0.560	0.0059	0.0170*
5	320	0.560	0.440	0.0248	
6	325	0.679	0.321	0.0025	0.0082
7	370	0.798	0.202	0.0040	0.0198
n=8	400	0.917	0.083		

Because the short interval of time between failures 5 and 6 produced a large increase in  $\hat{h}(t)$ , this interval was combined with the previous interval and  $h(t=300)$  was estimated as follows:

$$h_4 = \frac{2}{(325 - 300)(8 - 4 + 0.7)} = 0.0170$$

With empirical data this kind of smoothing must frequently be done

Some of the calculations are shown below:

$$h_1 = \frac{1}{(245-190)(n-1+0.7)} = 0.0024 \quad R_1 = 1 - \frac{1-0.3}{n+0.4} = R(195) = 0.9167$$

$$h_3 = \frac{1}{(300-265)(n-3+0.7)} = 0.0050 \quad R_4 = 1 - \frac{4-0.3}{n+0.4} = R(300) = 0.5595$$

$$h_6 = \frac{1}{(370-325)(n-6+0.7)} = 0.0082 \quad R_6 = 1 - \frac{6-0.3}{n+0.4} = R(325) = 0.3214 \blacktriangle$$

### Example 1-13

In Example 1-9, 10 units of a kind of components were placed on life test. The failures occurred at the following times:

5 10 17.5 30 40 55 67.5 82.5 100 117.5

Use Eqs. 1-38 through 1-41 to estimate  $F(t)$ ,  $R(t)$ ,  $f(t)$  and  $h(t)$

### Solution

The computations are shown in the following table<sup>1</sup>.

$i$	$t = t_{(i)}$	$\hat{f}(t) = \frac{1}{(t_{(i+1)} - t_{(i)})(n + 0.4)}$	$\hat{F}(t) = \frac{i - 0.3}{n + 0.4}$	$\hat{R}(t) = 1 - \hat{F}(t)$	$\hat{h}(t) = \frac{1}{(t_{(i+1)} - t_{(i)})(n - i + 0.7)}$
1	5	$\frac{1}{(10 - 5)(10 + 0.4)} = 0.0192$	$\frac{1 - 0.3}{10 + 0.4} = 0.0673$	0.9327	$\frac{1}{(10 - 5)(10 - 1 + 0.7)} = 0.0206$
2	10	0.0128	0.1635	0.8365	0.0153
3	17.5	0.0077	0.2596	0.7404	0.0104
4	30	0.0096	0.3558	0.6442	0.0149
5	40	0.0064	0.4519	0.5481	0.0117
6	55	0.0077	0.5481	0.4519	0.0170
7	67.5	0.0064	0.6442	0.3558	0.0180
8	82.5	0.0055	0.7404	0.2596	0.0212
9	100	0.0055	0.8365	0.1635	0.0336
10	117.5	Cannot be computed	0.9327	0.0673	Cannot be computed

End of Example ▲

<sup>1</sup> Prepared by: Mr M Morrdi former student of Kerman University

In summary, if the lifetime distribution is known or could be specified, the relationships related to the distribution have to be used for reliability computations; if the distribution is unknown but sufficient data regarding the lifetime is available, the relationships related to grouped data should be used, otherwise prepare an ordered sample of the lifetimes and perform the calculations using the ordered sample.

### 1-12 The density function & Cumulative distribution function of sample minimum

Suppose random sample of size  $n$  ( $X_1, X_2, \dots, X_n$ ) is taken from a statistical distribution having CDF  $F_X(x)$   $-\infty < x < \infty$ . Either the smallest or the largest of the  $n$  observations is referred to as an extreme value statistic. Practical applications of extreme value statistics are many; e.g. a chain is not stronger than its weakest link. Let  $X_{(1)}$  denote the smallest of the  $n$  observations. If  $X_1, X_2, \dots, X_n$  are independent then:

$$\Pr(X_{(1)} > y) = \Pr[(X_1 > y), (X_2 > y), \dots, (X_n > y)] = \prod_{i=1}^n \Pr(X_i > y) \Rightarrow$$

$$\Pr(X_{(1)} > y) = [1 - F_X(y)]^n \text{ or}$$

$$F_{X_{(1)}}(y) = 1 - [1 - F_X(y)]^n \quad -\infty < y < \infty \quad (1-42)$$

If the distribution of  $X_i$  is continuous then the density function of  $X_{(1)}$  is:

$$f_{X_{(1)}}(y) = \frac{d}{dy} F_{X_{(1)}}(y) \quad -\infty < y < \infty \quad (1-43)$$

### Example 1-14

Random samples of size  $n$  are taken from a population whose pdf and CDF are:

$$f(x) = \lambda e^{-\lambda x} \quad x \geq 0, \quad F_X(x) = 1 - e^{-\lambda x} \quad x \geq 0$$

Find the pdf and CDF of the smallest extreme value.

### Solution

The CDF of the smallest value of the  $n$  observation is given by Eq. 1-42

$$F_{X_{(1)}}(y) = 1 - [1 - 1 + e^{-\lambda y}]^n = \begin{cases} 1 - e^{-n\lambda y} & y \geq 0 \\ 0 & y < 0 \end{cases}$$

The pdf is given by Eq. 1-43:  $f_{X_{(1)}}(y) = n\lambda e^{-n\lambda y}$ ,  $y \geq 0$ ;  
therefore:

**The minimum of the samples of size  $n$  taken from an exponential distribution with parameter  $\lambda$  has an exponential distribution with parameter  $n\lambda$ .**

End of example ▲

### 1-12-1 The CDF of the minimum of samples of largish size taken from a population with known $F_X(x)$

If the CDF  $F_X(x)$  of the population from which the samples are taken is known, as the sample size  $(n)$  becomes large<sup>1</sup> the following approximate approach is helpful in the study of the sample minimum distribution (from K&L page 42).

To derive  $F_{X_{(1)}}(y)$ , when the sampling size  $(n)$  from the distribution with CDF  $F_X(x)$  is large, let random variable  $U_n$  be defined as:  $U_n = nF_X(X_{(1)})$  which has a value between 0 & 1. This variable is used in determining the limiting distribution of  $X_{(1)}$ . Below it is shown that  $F_{U_n}(u)$  i.e. the CDF of  $U_n$  is as follows:

$$F_{U_n}(u) = 1 - \left(1 - \frac{u}{n}\right)^n \quad (1-44)$$

And as  $n$  approaches infinity we have:

$$\lim_{n \rightarrow \infty} F_{U_n}(u) = F_U(u) = 1 - e^{-u} \quad (1-45)$$

Proof:

$$F_{U_n}(u) = Pr(U_n \leq u) = Pr[nF_X(X_{(1)}) \leq u] \Rightarrow$$

$$F_{U_n}(u) = Pr\left[F_X(X_{(1)}) \leq \frac{u}{n}\right] = Pr\left[X_{(1)} \leq F^{-1}\left(\frac{u}{n}\right)\right] \Rightarrow$$

---

<sup>1</sup> This assumption in the fracture of structures is logical because the number of their defects are large.

$$F_{U_n}(u) = F_{X_{(1)}} \left[ F_X^{-1} \left( \frac{u}{n} \right) \right] \quad 0 \leq u \leq n$$

Substituting  $y = F_X^{-1} \left( \frac{u}{n} \right)$ , in Eq. 1-42 i.e

$$F_{X_{(1)}}(y) = 1 - [1 - F_X(y)]^n$$

$$F_{X_{(1)}} \left( F_X^{-1} \left( \frac{u}{n} \right) \right) = 1 - \left[ 1 - F_X \left( F_X^{-1} \left( \frac{u}{n} \right) \right) \right]^n$$

Since  $F[F^{-1}(x)] = x$  then the CDF of  $U_n$  is:

$$F_{U_n}(u) = 1 - \left( 1 - \frac{u}{n} \right)^n \quad 0 \leq u \leq n$$

We know from mathematics that

$$\lim_{n \rightarrow \infty} \left\{ \left( 1 - \frac{u}{n} \right)^n \right\} = e^{-u} \quad u \geq 0 \quad \text{therefore:}$$

$$\lim_{n \rightarrow \infty} F_{U_n}(u) = 1 - e^{-u} \quad u \geq 0$$

Here it is reasoned that (K&L p 42, Mann et al, 1974p 102): that since the sequence of the following CDF's converges to  $1 - e^{-u}$

$$F_{U_1}(u) = 1 - \left( 1 - \frac{u}{1} \right)^1, \dots, F_{U_n}(u) = 1 - \left( 1 - \frac{u}{n} \right)^n$$

Therefore the sequence of random variable  $U_n$  i. e

$$U_1 = 1F_X(X_{(1)}), \quad U_2 = 2F_X(X_{(1)}), \dots, \quad U_n = nF_X(X_{(1)})$$



Converges in distribution to a random variable U with CDF

$$1 - e^{-u}:$$

$$F_U(u) = \lim_{n \rightarrow \infty} F_{U_n}(u) = 1 - e^{-u}$$

The pdf of U is:

$$f_U(u) = \frac{dF_U(u)}{du} = f_U(u) = e^{-u} \quad u \geq 0. \text{End of proof} \blacksquare$$

Now notice that

since  $U_n = nF_X(X_{(1)})$  then  $X_{(1)} = F^{-1}\left(\frac{U_n}{n}\right)$  and the sequence of random variables  $X_{(1)}$  converges in distribution to a random variable, say Y, where

$$Y = F_X^{-1}\left(\frac{U}{n}\right) \quad \text{and} \quad U = \text{limiting } U_n = \text{limiting } nF_X(X_{(1)})$$

Thus for large sample size( n) the limiting distribution of the smallest extreme value( $X_{(1)}$ ) is given by the distribution of Y as described in the following steps;

**Derivation of  $F_{\text{limiting } X_{(1)}}$  i.e. the CDF of sample minimum or  $X_{(1)}$  when sample size  $n \rightarrow \infty$**

Step1 Given  $F_X(x)$  substitute  $x=X_{(1)}$ .

Step 2 Let  $U_n = nF_X(X_{(1)})$  then calculate its inverse i.e.

$X_{(1)} = \dots$  in terms of  $U_n$

Step 3 Calculate the limiting  $X_{(1)}$  in terms of  $U$ (=limiting  $U_n$ )  
from step 2

Step 4 Calculate the following:

$$F_{\text{limiting } X_{(1)}}(y) = \Pr(\text{limiting } X_{(1)} < y)$$

From this relationship calculate  $F_{\text{limiting } X_{(1)}}$  in terms of

$$\Pr(U < \dots) = F_U.$$

Step 5 Calculate  $F_{\text{limiting } X_{(1)}}(y)$ , considering step 4 and

$$\text{Eq. 1-45 i. e. } \Pr(U \leq u) = 1 - e^{-u}.$$

Examples 1-15 and 1-16 illustrates the derivation.

### **Example 1-15**

Random samples of size  $n$  are taken from a uniform distribution on  $[0, 1]$ . What is the CDF and pdf of the smallest extreme value when  $n \rightarrow \infty$ .

### **Solution**

The density function of the uniform distribution is:

$$f_X(x) = \begin{cases} \frac{1}{a} & 0 \leq x \leq a \\ 0 & \text{o.w} \end{cases}$$

To derive the CDF of the sample minimum as  $n \rightarrow \infty$  the above 5 steps are followed:

### Step 1

$$F_X(x) = \frac{x - 0}{a} \Rightarrow F_X(X_{(1)}) = \frac{X_{(1)}}{a}$$

### Step 2

$$U_n = nF_X(X_{(1)}) \Rightarrow U_n = \frac{nX_{(1)}}{a} \Rightarrow X_{(1)} = \frac{a}{n}U_n$$

### Step 3

Let  $U$  = the limiting value of  $U_n$ , then:

$$X_{(1)} \underset{n \rightarrow \infty}{=} \frac{a}{n}(U)$$

### Step 4

$$F_{\text{limiting } X_{(1)}}(y) = Pr(X_{(1)} \leq y) = Pr\left(\frac{aU}{n} \leq y\right) = Pr\left(U \leq \frac{n}{a}y\right)$$

$$\Rightarrow F_{\text{limiting } X_{(1)}}(y) = Pr\left(U \leq \frac{n}{a}y\right) = F_U\left(\frac{n}{a}y\right)$$

**Step 5**

According to Eq. 1-45 the CDF of U is

$$F_U(u) = 1 - e^{-u} \quad u > 0; \text{ then}$$

$$F_{\text{limiting } X_{(1)}}(y) = F_U\left(\frac{n}{a}y\right) = 1 - e^{-\frac{n}{a}y}, \quad \frac{n}{a}y \geq 0 \Rightarrow$$

$$F_{\text{limiting } X_{(1)}}(y) = 1 - e^{-\frac{n}{a}y}, \quad y \geq 0$$

Taking derivative yields the pdf as follows:

$$f_{\text{limiting } X_{(1)}}(y) = \begin{cases} \frac{n}{a} e^{-\frac{n}{a}y} & y \geq 0 \\ 0 & \text{others} \end{cases} \text{ .End of Example } \blacktriangle$$

**Example 1-16**

Random samples of size  $n$  are taken from an exponential distribution with parameter  $\lambda$ . What is the CDF and pdf of the smallest extreme value when  $n \rightarrow \infty$ .

**Solution**

The density function of the uniform distribution is:

$$f_X(x) = \begin{cases} \lambda e^{-\lambda x} & x \geq 0 \\ 0 & \text{o.w} \end{cases}$$

To derive the CDF of the sample minimum as  $n \rightarrow \infty$  the above 5 steps are followed:

### Step 1

$$F_X(x) = 1 - e^{-\lambda x} \quad F_X(X_{(1)}) = 1 - e^{-\lambda X_{(1)}}$$

### Step 2

$$U_n = nF_X(X_{(1)}) \Rightarrow U_n = n[1 - e^{-\lambda X_{(1)}}] \Rightarrow$$

$$X_{(1)} = \frac{1}{\lambda} \ln \frac{1}{1 - \frac{U_n}{n}} = -\frac{1}{\lambda} \ln \left(1 - \frac{U_n}{n}\right)$$

Taylor expansion of  $f(x)$  about  $x=a$  is:

$$f(x) = f(a) + \frac{1}{1!} f'(a)(x - a) + \frac{1}{2!} (x - a)^2 f''(a) + \dots$$

This expansion for  $\ln(1 + x)$ ,  $-1 < x \leq 1$  is:

$$\ln(1 + x) = 0 + x - \frac{1}{2} x^2 + \frac{1}{3} x^3 - \frac{1}{4} x^4 + \dots$$

Let  $x = -\frac{U_n}{n}$ ; then

$$X_{(1)} = -\frac{1}{\lambda} \left[ -\frac{U_n}{n} - \frac{1}{2} \left(\frac{U_n}{n}\right)^2 - \frac{1}{3} \left(\frac{U_n}{n}\right)^3 - \dots \right]$$

### Step 3

Let as  $n \rightarrow \infty$   $U =$  the limiting value of  $U_n$ . Ignoring the terms of order 2 and higher we could say that the distribution of  $X_{(1)}$

when  $n \rightarrow \infty$  approaches the distribution of  $\frac{U}{n\lambda}$  :

$$X_{(1)} \underset{n \rightarrow \infty}{=} \frac{1}{\lambda n} \times U.$$

**Step 4**

$$F_{\text{limiting } X_{(1)}}(y) = \Pr(\text{limiting } X_{(1)} < y) = \Pr\left(\frac{U}{n\lambda} \leq y\right) = \Pr(U \leq n\lambda y)$$

$$\Rightarrow F_{\text{limiting } X_{(1)}}(y) = F_U(n\lambda y)$$

**Step 5**

According to Eq. 1-45 the CDF of U is

$$F_U(u) = 1 - e^{-u} \quad u > 0; \text{ then}$$

$$F_{\text{limiting } X_{(1)}}(y) = F_U(n\lambda y) = 1 - e^{-n\lambda y}, \quad n\lambda y \geq 0 \Rightarrow$$

$$F_{\text{limiting } X_{(1)}}(y) = 1 - e^{-n\lambda y}, \quad y \geq 0$$

Taking derivative yields the pdf as follows:

$$f_{\text{limiting } X_{(1)}}(y) = \begin{cases} e^{-n\lambda y} & y \geq 0 \\ 0 & \text{others} \end{cases}$$

End of Example ▲

The following example (extracted from K&L p 45) shows an application of GEV distribution to reliability.

### Example 1-17

An application of the extreme value distribution is to study the failures of car exhausts caused by corrosion.

Consider a kind of automotive exhaust pipe that has various pits when new. The exhaust gases and other corrosives increase the depth of these pits and, ultimately, a failure occurs when the exhaust gases can escape through one pit that has penetrated the thickness of the pipe and has become a hole. If we assume that the time of penetration is proportional to the difference between the pipe thickness ( $D$ ) and the initial pit depth ( $d_i$ ) and  $d_i$  has a truncated exponential probability distribution between  $(0, D)$ , show that the time to failure of the exhaust pipes is a GEV distribution and find the reliability function.

### Solution

#### Symbols

$D$	Exhaust pipe thickness
$d_i$	Initial pit depth of $i^{\text{th}}$ pit $i=1,2,\dots,N$
$t_i$	Failure time of $i^{\text{th}}$ pit
$N$	Number of pits.
$T$	Failure time of the exhaust pipe

The distribution of  $d_i$  is a truncated exponential with the following density function:

$$f_{d_i}(x) = \frac{\lambda e^{-\lambda x}}{\Pr(0 \leq x \leq D)} = \frac{\lambda e^{-\lambda x}}{1 - e^{-\lambda D}} \quad 0 \leq x \leq D$$

Since the failure time of  $i^{\text{th}}$  pit ( $t_i$ ) is proportional to  $(D - d_i)$ , then

$t_i = k(D - d_i)$ , where  $k > 0$  is the constant of proportionality.

The cumulative distribution of  $t_i$  is as follows

$$\begin{aligned} F_{t_i}(t) &= \Pr(t_i \leq t) = \Pr((kD - kd_i) \leq t) = \Pr(kD - t \leq kd_i) \Rightarrow \\ F_{t_i}(t) &= \Pr\left(D - \frac{t}{k} \leq d_i\right). \end{aligned}$$

Since the maximum of  $d_i$  is  $D$ , then:

$$F_{t_i}(t) = \Pr\left(D - \frac{t}{k} \leq d_i \leq D\right) = F_{d_i}(D) - F_{d_i}\left(D - \frac{t}{k}\right)$$

where

$D$  is the thickness of the pipe and

$d_i$ , the initial depth of the  $i^{\text{th}}$  pit,  $i=1,2,\dots,N$ .

$N$  is the number of pits.

The  $d_i$ 's constitute a random sample from a truncated exponential distribution defined on the interval  $(0, D)$ :



$$F_{d_i}(x) = \frac{1-e^{-\lambda x}}{1-e^{-\lambda D}}, \quad 0 \leq x \leq D, i = 1, 2, \dots, N$$

Therefore

$$\begin{aligned} F_{t_i}(t) &= F_{d_i}(D) - F_{d_i}\left(D - \frac{t}{k}\right) = \frac{1-e^{-\lambda D}}{1-e^{-\lambda D}} - \frac{1-e^{-\lambda\left(D-\frac{t}{k}\right)}}{1-e^{-\lambda D}} = \\ &= \frac{e^{-\lambda\left(D-\frac{t}{k}\right)} - e^{-\lambda D}}{1-e^{-\lambda D}} = \frac{e^{-\lambda D} \cdot e^{\frac{\lambda t}{k}} - e^{-\lambda D}}{1-e^{-\lambda D}} \Rightarrow \end{aligned}$$

Since  $D - \frac{t}{k} \geq 0$  and  $D - \frac{t}{k} \leq D$  then  $0 \leq t \leq kD$  and

$$F_{t_i}(t) = \frac{e^{\frac{\lambda t}{k}} - 1}{e^{\lambda D} - 1} \quad 0 \leq t \leq kD, i = 1, 2, \dots, N$$

Let  $T$  = the failure time of the entire exhaust pipe, then

$T = \min_{i=1}^N (t_i)$  and its CDF is:

$$F_T(t) = Pr(T < t) = 1 - Pr(T > t) = 1 - Pr(t_1 > t, \dots, t_N > t)$$

Assuming  $t_1, \dots, t_N$  are independent and similar, we could write:

$$F_T(t) = 1 - Pr(t_1 > t) \dots Pr(t_N > t) = 1 - [1 - F_{t_1}(t)] \dots [1 - F_{t_N}(t)]$$

$$F_T(t) = Pr(T < t) = 1 - [1 - F_{t_i}(t)]^N$$

In mathematics it is shown that for  $0 < a < 1$ ,  $[1 - a]^N$  approaches  $e^{-Na}$  as  $\rightarrow \infty$ , then

Since  $0 \leq F_{t_i}(t) \leq 1$  and there are a lot of pits in the pipe, therefore  $F_T(t) \cong 1 - e^{-N \times F_{t_i}(t)}$ .

We saw earlier  $F_{t_i}(t) = \frac{e^{\frac{\lambda t}{k}} - 1}{e^{\lambda D} - 1}$  then:

$$F_T(t) = 1 - e^{-N \frac{e^{\frac{\lambda t}{k}} - 1}{e^{\lambda D} - 1}} \Rightarrow R(t) = 1 - F_T(t) = e^{-N \frac{e^{\frac{\lambda t}{k}} - 1}{e^{\lambda D} - 1}}$$

This is an extreme value or a GEV distribution(K&L page 46) ▲.

### Example 1-18

In the previous example, suppose  $D = \frac{1}{16}$  inch,  $N = 10^4$ ,  $k=10^6$  hr/in and the average depth of pits is  $\frac{1}{128}$  in. Find the life time that will give a reliability of 90% .

### Solution

If the pdf of the initial depth of a pit were  $\lambda e^{-\lambda d_i}$ , the average depth would be  $\frac{1}{\lambda} = \frac{1}{128}$  and  $\lambda = 128$ . However here the pdf is  $f_{d_i}(x) = \frac{\lambda e^{-\lambda x}}{1 - e^{-\lambda D}}$  and to find the value of  $\lambda$  the following equation has to be solved:

$$E(d_i) = \int_0^D x f_{d_i}(x) dx = \frac{1}{128} \quad \begin{cases} D = \frac{1}{16} \text{ in} \\ E(d_i) = \frac{1}{128} \text{ in} \end{cases}$$

$$E(d_i) = \int_0^D x \left( \frac{\lambda e^{-\lambda x}}{1 - e^{-\lambda D}} \right) dx = \frac{1}{128} \Rightarrow \frac{\int_0^D \lambda x e^{-\lambda x} dx}{1 - e^{-\lambda D}} = \frac{1}{128}$$

Solving the equation  $\frac{\int_0^D \lambda x e^{-\lambda x} dx}{1 - e^{-\lambda D}} = \frac{1}{128}$  in MATLAB:

```
>>syms landa x; landa =solve((int(landa*x*exp(-
landa*x),x,0,1/16))./(1-exp(-landa/16))=1/128)
```

```
landa=127.64972
```

Notice that ignoring  $e^{-\lambda D}$  from the denominator yields  $\lambda = 128$ .

Substituting the followings in  $R(t) = e^{-N \frac{\exp(\frac{\lambda t}{k}) - 1}{e^{\lambda D} - 1}}$

$N = 10^4$  ,  $k = 10^6$  ,  $D = \frac{1}{16}$  ,  $\lambda = 128$  ,  $R(t) = 0.9$

Yields  $t \cong 242$  hr. ▲

## Fisher -Tippet and central limit Theorems

Fisher -Tippet Theorem

If  $X_1, \dots, X_n$  are independent and identically distributed(iid) random variables then as n increases the distribution of the maximum of these variables approaches a GEV distribution and the distribution of the minimum of these variables ] approaches another GEV distribution. ■

It is worth mentioning that:

- 1) in the original theorem by Fisher and Tippet, states that the limiting distribution is one of three extreme value

distributions ( $EV^1=FT1$ ,  $EV2=FT2$  and  $EV3=FT3$ ) but Jerkinson(1955) showed that the aforementioned three limiting distributions can be unified into a single expression known as the generalized extreme value (GEV) distribution.

- 2) This theorem is used in extreme value analysis such finding the possible maximum of wind speed, wave length, etc.... Interested readers could refer to references such as Coles (2001).
- 3) For using this theorem, some random samples of largish size from the desired population are needed. Extract their minimum or maximum and prepare a vector (titled say *Data*) of the minima or the maxima. Then use `gevfit(Data)` command to estimate the fitting GEV.

### Central Limit Theorem

According to the **central limit theorem** the mean of random samples  $X_1, \dots, X_n$  of sufficiently large size  $n$  from a population with mean  $\mu$  and finite variance  $\sigma^2$ , tends towards a normal distribution with mean  $\mu$  and finite variance  $\frac{\sigma^2}{\sqrt{n}}$ ; even if the original distribution is not normally distributed. The theorem also

---

<sup>1</sup> Extreme value 1=Fisher Tippet 1

states that sum of the sample elements ( $\sum X_i$ ) tends towards a normal distribution with mean  $\mu$  and finite variance  $n\sigma^2$ .

### 1-13 Bartlett's goodness of fit(GOF) test for exponential distribution

To deal with the following hypotheses using a GOF test

$H_0$ : The distribution is exponential

$H_1$ : The distribution is not exponential

we could use the Bartlett' test described below:

Take a random sample of size at least 20 : $t_1, \dots, t_r$   $r \geq 20$ , where  $t_i$  is the time of the  $i^{\text{th}}$  event; calculate the statistic  $B$  given by(K&L p239):

$$B = \frac{2r \left[ \ln \left( \left( \frac{1}{r} \right) \sum_{i=1}^r t_i \right) - \left( \frac{1}{r} \right) \sum_{i=1}^r \ln t_i \right]}{1 + \frac{r+1}{6r}} \quad (1-46)$$

which has a chi-squared distribution with  $r-1$  degrees of freedom under the null hypothesis  $H_0$ . If  $B$  is outside the

interval  $[\chi_{1-\frac{\alpha}{2}, r-1}^2, \chi_{\frac{\alpha}{2}, r-1}^2]$ , reject  $H_0$ ;  $\alpha$  is the level of

significance of the test.

$\chi_{\frac{\alpha}{2}, r-1}^2$  is read from Table E or calculated in MATLAB from

$$\text{chi2cdf}(1 - \frac{\alpha}{2}, r - 1)$$

$\chi_{1-\frac{\alpha}{2}, r-1}^2$  is read from Table E or calculated in MATLAB

from  $\text{chi2cdf}(\frac{\alpha}{2}, r - 1)$ .

### Example 1-19

The following sample of size  $r=20$  is available from the lifetime of a kind of electric bulb. Does an exponential distribution fit the lifetime data? Use Bartlett's test with  $\alpha = 10\%$ . If the answer is yes, give the mean and the pdf of the distribution?

50.1	20.9	31.1	96.5	36.3	99.1	42.6	84.9	6.2	32.0
30.4	87.7	14.2	4.6	2.5	1.8	11.5	84.6	88.6	10.7

### Solution

$H_0$ : The lifetime distribution is exponential

$H_1$ : The distribution is not exponential

Let  $t_i, i = 1, \dots, r = 20$  be the sample values. We use Bartlett's test:

$$B = \frac{2r \left[ \ln \left( \left( \frac{1}{r} \right) \sum_{i=1}^r t_i \right) - \left( \frac{1}{r} \right) \sum_{i=1}^r \ln t_i \right]}{1 + \frac{r+1}{6r}}$$

$$\sum_{i=1}^{20} t_i = 50.1 + 20.9 + \dots + 88.6 + 10.7 = 836.3$$

$$\sum_{i=1}^{20} \ln(t_i) = \ln 50.1 + \ln 20.9 + \dots + \ln 88.6 + \ln 10.7 = 63.9385$$

$$B = \frac{2 \times 20 \left[ \ln \left( \frac{836.3}{20} \right) - \frac{63.94}{20} \right]}{1 + \frac{20+1}{6 \times 20}} = 19.34$$

$$\chi_{1-\frac{\alpha}{2}, r-1}^2 = \text{chi2inv}(0.05, 19) = 10.1170$$

$$\chi_{\frac{\alpha}{2}, r-1}^2 = \text{chi2inv}(0.95, 19) = 30.1415$$

$H_0$  is not rejected because, the value of statistic B does not

fall outside  $\left[ \chi_{1-\frac{\alpha}{2}, r-1}^2 \quad \chi_{\frac{\alpha}{2}, r-1}^2 \right]$ . Therefore the

distribution of the bulbs are fitted to an exponential

distribution with the mean and pdf:

$$\hat{\theta} = \frac{\sum_{i=1}^{20} t_i}{20} = \frac{836.3}{20} \cong 41.82, \quad f(t) = \frac{1}{\theta} \times e^{-\frac{t}{\theta}} = \frac{e^{-\frac{t}{41.82}}}{41.82} \blacktriangle$$

It is worth mentioning that using Kolomogrov-Smironov

test in MATLAB does not reject  $H_0$

```
>>Data=[...  
50.1  
...  
10.7];  
>> H=kstest(Data, [Data expcdf(Data,mean(Data))] , 0.1)  
H=0
```

This means that  $H_0$  is not rejected at the significance level of 10%. ▲

### 1-14 Q-Q plot

Quantile-Quantile(Q-Q) plot is a graphical device to observe whether a particular distribution fits a dataset or not. In this graph the observed data and the corresponding data obtained from the distribution are plotted versus each other in an X-Y coordinate plane. The better the population follows the distribution, the closer the points to the angle bisector of the first quarter of the X-Y plane. The procedure for preparing a Q-Q plot is as follows:

- Sort The sample of data from minimum to maximum, giving rank 1 through n:  $X_{(1)}, \dots, X_{(n)}$
- Allocate a number  $F(i)$ , called plotting position calculated from one the following formulae to each  $x_{(i)}$ . In fact



$F(i)$  is a number near to relative frequency and an estimate for the cumulative distribution function at  $x_{(i)}$ .

There are many formulae for plotting position including the followings:

#### A) Gumbel Plotting position

One of the first formulae for plotting position was given by Gumbel:

$$F(i) = \frac{i}{n+1}, \quad i = 1, \dots, n \quad (1-47)$$

#### B) Plotting position for normal distribution

There are some formulae for the normal case including

(Besterfield, 1990 page 52):

$$F(i) = \frac{i - 0.5}{n} \quad (1-47-1)$$

or (Goda, 2000 page 287):

$$F(i) = \frac{i - 0.375}{n + 0.25}. \quad (1-47-2)$$

### C) Plotting position for Weibull distribution with parameters A,B,C

The Plotting position for Weibull distribution with parameters A,B,C is (Goda,2000 page 287):

$$F(i) = \frac{i - a}{n + b} \quad (1-48)$$

$$\text{where } a = 0.20 + \frac{0.27}{\sqrt{C}} \quad b = 0.20 + \frac{0.23}{\sqrt{C}}$$

### D) Plotting position for Exponential Distribution

Since Exponential distribution could be considered a Weibull with C=1 then:

$$F(i) = \frac{i - 0.47}{n + 0.43} \quad (1-48-1)$$

- From  $F_x[\hat{x}_{(i)}] = F(i)$  for each F(i), i=1,...,n calculate  $\hat{x}_{(i)}$ , i=1,...,n from where  $F_x$  is the cumulative distribution function of the distribution under study.
- Plot the pairs  $(x_{(i)} \& \hat{x}_{(i)})$  in an X-Y coordinate plane, and fit a line to the points. The closer this line to the angle bisector of the first quarter of the plane, the better fits the distribution to the dataset. It is worth knowing that the better the distribution fits the data set the closer the correlation coefficient of  $x_{(i)}$  &  $\hat{x}_{(i)}$  to 1; but the vice

versa is not necessarily true i.e. if the correlation coefficient of  $x_{(i)}$  &  $\hat{x}_{(i)}$  is close to 1, necessarily the distribution does not fit the dataset well.

The correlation coefficient is calculated by the following formula:

$$R = \frac{n \sum x_{(i)} \hat{x}_{(i)} - \sum x_{(i)} \sum \hat{x}_{(i)}}{\sqrt{n \sum x_{(i)}^2 - (\sum x_{(i)})^2} \sqrt{n \sum \hat{x}_{(i)}^2 - (\sum \hat{x}_{(i)})^2}} \quad (1-49)$$

### Example 1-20

The following table shows a sorted random sample,  $x_{(i)}$  's, from a population. Is the sample a representative of normal distribution?

### Solution

To answer, a Q-Q plot is drawn. The mean and variance of the distribution is estimated as follows:

$$\hat{\mu} = \bar{X} = 54. \quad , \quad \hat{\sigma} = \frac{s}{c_4} = 11.7287$$

$F(i)$ ,  $i=1, \dots, n$  was computed using  $F(i) = \frac{i - 0.375}{n + 0.25}$  as the plotting position, and inserted in the table. Then the corresponding  $\hat{x}_{(i)}$  is calculated by equating the  $F(i)$  to the

normal standard cumulative distribution, and calculating  $\hat{x}_{(i)}$  from these equations.

$$\Pr(X < \hat{x}_{(i)}) = \Pr(Z < \frac{\hat{x}_{(i)} - \hat{\mu}}{\hat{\sigma}}) = F(i) \quad \hat{\mu} = \bar{X}, \quad \hat{\sigma} \cong \frac{s}{c_4}$$

sample calculation follows:

For  $i = 1$ :

$$\Pr(Z < \frac{\hat{x}_{(i)} - \hat{\mu}}{\hat{\sigma}}) = F(i), \quad \Pr(Z < \frac{\hat{x}_{(1)} - 54.81}{11.7287/0.9876}) = 0.0294 \Rightarrow \hat{x}_{(1)} \cong 32.37$$

or  $\hat{x}_{(1)} = \text{norminv}(0.0294, 54.81, 11.8751) = 32.3698$ .

The following table contains all the results

Rank(i)	$x_{(i)}$	F(i)	$\hat{x}_{(i)}$	Rank(i)	$x_{(i)}$	F(i)	$\hat{x}_{(i)}$
1	32	0.0294	32.37	12	59	0.5471	56.21
2	34	0.0765	37.84	13	59	0.5941	57.64
3	39	0.1235	41.06	14	60	0.6412	59.10
4	44	0.1706	43.51	15	61	0.6882	60.64
5	46	0.2176	45.55	16	64	0.7353	62.28
6	47	0.2647	47.34	17	67	0.7824	64.08
7	50	0.3118	48.98	18	68	0.8294	66.11
8	51	0.3588	50.52	19	70	0.8765	68.56
9	51	0.4059	51.98	20	70	0.9235	71.78
10	52	0.4529	53.41	21	71	0.9706	77.25
11	56	0.5000	54.81				

Fig.1.14 2 shows  $x_{(i)}$ 's versus  $\hat{x}_{(i)}$ 's and a line fitted to them.

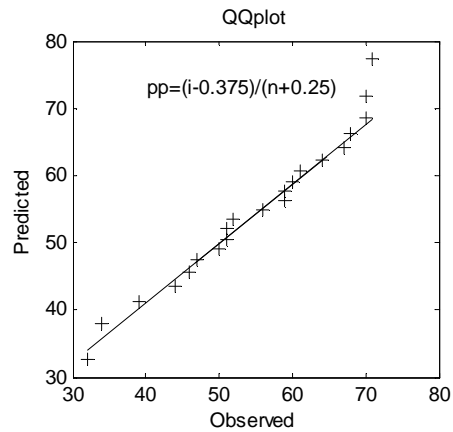

Fig. 1.14-1 Q-Q plot with

$$F(i) = \frac{i-0.375}{n+0.25}$$

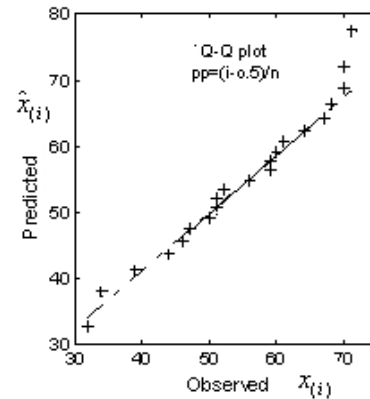

Fig. 1.14-2 Q-Q plot

$$\text{with } F(i) = \frac{i-0.5}{n}$$

Since the points are near to the fitted line and the line is close to the angle bisector of the first quarter of the X-Y coordinate plane, it is concluded that the normal distribution fits the dataset.

In MATLAB, the command *qqplot* could be utilized to make a Q-Q plot from the normally distributed dataset  $X$ . The Q-Q plot of Fig. 1.13-1 was made by this command. The difference of the two plots is not significant. It is worth mentioning that if the dataset  $X$  is not normally distributed, the following MATLAB command could be used to plot the Q-Q plot:

```
X=[data]; pd=makedist('Distribution name'...);qqplot(X,pd)
```

The correlation coefficient( $r$ ) between  $\hat{x}_{(i)}, x_{(i)}$  is calculated by

$$r=\text{corrcoef}(X,X\text{hat});r=R(1,2)$$

where

$X$  is the vector containing  $x_{(i)}$ ,  $i=1,2,3..$

$X_{hat}$  is the vector containing  $\widehat{x}_{(i)}$ ,  $i = 1,2,..$  which gives 0.9826. This value, being near to 1, together with the Q-Q plot of Fig. 1-13=1 or Fig. 1-13-2 indicate that normal distribution is a good fit for the data best fit. ▲

## 1-15 Convolution

Since the concept of convolution of functions in statistics and probability is used to find the distribution of the sum of independent continuous random variables  $X$  and  $Y$  having the density function (pdf),  $f_X(x)$  and  $f_Y(y)$  and the cumulative distribution function  $F_X(x)$  and  $F_Y(y)$ ; this concept is reviewed below.

### 1-15-1 CDF and pdf of sum of independent variables $X$ and $Y$

Let  $X$  and  $Y$  be 2 independent random variables and  $Z=X+Y$ .

a)The CDF of  $Z$  i.e.  $F_{X+Y}(a)$  is derived from the following relationship which is called the convolution of  $F_X$  &  $F_Y$  and is denoted by  $F_X * F_Y$ :

$$F_{X+Y}(a) = F_X * F_Y(a) = \int_{-\infty}^{\infty} F_X(a - y)f_Y(y)dy \quad (1-50)$$

**Proof** (from Ross,1983 page 17):

$$F_{X+Y}(a) = \Pr(X + Y \leq a) = \int_{-\infty}^{\infty} \Pr(X + Y \leq a | Y = y) f_Y(y) dy =$$

$$\int_{-\infty}^{\infty} \Pr(X + y \leq a | Y = y) f_Y(y) dy = \int_{-\infty}^{\infty} F_X(a - y) f_Y(y) dy.$$

End of proof of section a ■

b) The pdf of Z i.e.  $f_{X+Y}(a)$  is derived from the following relationship which is called the convolution of  $f_X$  &  $f_Y$  and is denoted by  $f_X * f_Y$ :

$$f_{X+Y}(a) = f_X * f_Y(a) = \int_{-\infty}^{\infty} f_X(a - y) f_Y(y) dy = \int_{-\infty}^{\infty} f_X(x) f_Y(a - x) dx \quad (1 - 51)$$

where

$f_X(x)$  is the pdf of random variable X

$f_Y(y)$  is the pdf of random variable Y

**Proof** (from Ross,1985 page 54):

$$f_{X+Y}(a) = \frac{d}{da} \int_{-\infty}^{\infty} F_X(a - y) f_Y(y) dy = \int_{-\infty}^{\infty} \frac{d}{da} F_X(a - y) f_Y(y) dy \Rightarrow$$

$$f_{X+Y}(a) = \int_{-\infty}^{\infty} f_X(a - y) f_Y(y) dy.$$

End of proof of section b ■

**Notice that**

- When calculating the convolution integral, usually it is easier to set the simpler function as the second function (Gordon, 1993).

- If the distribution of  $X+Y$  is known for us, there is no need for the above integrations

- The concept of convolution has been extended for more than 2 functions.

**Example 1-20** (Ross, 1985 page 54)

$X$  and  $Y$  are independent uniformly distributed random variables on the interval  $(0, 1)$ . Find the density function of  $X+Y$ .

**Solution**

$$f_{X+Y}(a) = \int_{y=-\infty}^{\infty} f_X(a-y)f_Y(y)dy$$

Considering the uniform distribution of  $X$  and  $Y$  on  $(0, 1)$ , it is evident that a value of  $X+Y$ , say  $a$ , lies in the interval  $(0, 2)$ ; mathematically  $0 \leq a \leq 2$ .

**To find the limits of the above integral notice that:**

For  $0 \leq y \leq 1$ ,  $f_Y(y)$  is nonzero and



$f_X(a - y) \neq 0$  for  $0 \leq a - y \leq 1$  or  $a - 1 \leq y \leq a$

Then the limits of the integral are the intersection of the intervals  $0 \leq y \leq 1$  and  $a - 1 \leq y \leq a$ . To calculate the resulting interval which depend on the value, we divide the range of  $0 \leq a \leq 2$  into  $0 \leq a \leq 1$  and  $1 \leq a \leq 2$ :

If  $0 \leq a \leq 1$ , as the following figure shows, the limits of integral would be  $0 \leq y \leq a$ :

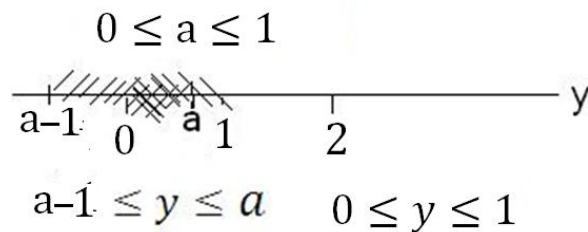

If  $1 \leq a \leq 2$ , using a similar figure it could be shown that the limits of integral would be  $a - 1 \leq y \leq 1$ .

Therefore

$$f_{X+Y}(a) = \int_{y=-\infty}^{\infty} f_X(a - y) f_Y(y) dy$$

$$= \begin{cases} \int_{y=0}^a 1 \times 1 dy & 0 \leq a \leq 1 \\ \int_{y=a-1}^1 1 \times 1 dy & 1 \leq a \leq 2 \end{cases} \Rightarrow$$

$$f_{X+Y}(a) = \begin{cases} a & 0 \leq a \leq 1 \\ 2 - a & 1 \leq a \leq 2 \end{cases} \blacktriangle$$

### Example 1-21

X and Y are 2 independent random variables with density functions  $f_X(x) = e^{-x}$ ,  $x \geq 0$  and  $f_Y(y) = e^{-y}$ ,  $y \geq 0$ . Find the density function of  $Z=X+Y$ .

### Solution No.1

$$f_{X+Y}(a) = \int_{y=-\infty}^{\infty} f_X(a-y)f_Y(y)dy$$

Considering the range of X and Y, we could say that  $a \geq 0$ .

**To find the limits of the above integral notice that:**

$f_Y(y) \neq 0$  for  $y \geq 0$  and

$f_X(a-y) \neq 0$  for  $a-y \geq 0$  or  $y \leq a$ .

Therefore the range of integral to become nonzero is  $0 \leq y \leq a$ :

$$f_{X+Y}(a) = \int_{y=0}^a f_X(a-y)f_Y(y)dy = \int_{y=0}^a e^{-(a-y)}e^{-y}dy = ae^{-a}, a \geq 0$$

### Solution No.2

$$f_{X+Y}(a) = \int_{y=-\infty}^{\infty} f_Y(a-x)f_X(x)dx.$$

with a similar reasoning for the range of integral:

$$f_{X+Y}(a) = \int_{x=0}^a e^{-(a-x)} e^{-x} dx = a e^{-a} \quad a \geq 0$$

### Solution No.3

As it is well known that the sum of 2 independent variable with the same parameter has a *Gamma* ( $n = 2, \lambda$ ) distribution, then:

$$f_{X+Y}(a) = \frac{\lambda e^{-\lambda a} (\lambda a)^{n-1}}{(n-1)!} = \frac{e^{-a} (a)^{2-1}}{(2-1)!} = a e^{-a} \quad a \geq 0 \blacktriangle$$

### Example 1-22

X and Y are independent random variables with normal( $\mu, \sigma$ ) and Uniform(0,1) distribution respectively. Find the density function of X+Y.

### Solution

$$f_{X+Y}(a) = \int_{y=-\infty}^{\infty} f_X(a-y) f_Y(y) dy$$

The range of  $a=x+y$  is  $-\infty < a < \infty$ .

**To find the limits of the above integral notice that:**

$f_Y(y) \neq 0$  for  $0 \leq y \leq 1$  and

$f_X(a-y) \neq 0$  for  $-\infty \leq a-y \leq \infty$  or  $-\infty \leq y \leq \infty$ .

The intersection of these 2 intervals is  $0 \leq y \leq 1$ . Therefore the integral is not zero between 0 to 1:

$$f_{X+Y}(a) = \int_{y=0}^1 f_X(a-y) \times 1 \, dy$$

If we let  $a-y = t$ , the range of  $t$  would be  $a-1 \leq t \leq a$

$$f_{X+Y}(a) = \int_{t=a}^{a-1} f_X(t)(-dt) = \int_{t=a-1}^a \frac{1}{\sigma\sqrt{2\pi}} e^{-\frac{1}{2}\left(\frac{t-\mu}{\sigma}\right)^2} dt \rightarrow$$

$$f_{X+Y}(a) = \varphi_Z(a) - \varphi_Z(a-1) \quad -\infty < a < \infty$$

where  $\varphi_Z$  is the CDF of standard normal distribution. ▲

### 1-15-2 n-fold convolution of f with itself

Suppose we have  $n$  independent random variables with the same density function  $f(x)$  and we want to derive the density function of their sum i.e.  $g(t) = f_{\sum X_i}(t)$ .  $g(t)$  which called  $n$ -fold convolution of  $f$  with itself and denoted by  $[f(t)]_{n*}$  is defined as follows:

$$g(t) = f(t) * [f(t)]_{(n-1)*} \quad (1-52)$$

Furthermore, denoting  $F * F$  by  $F_{2*}$ ,  $F_{n*}$ , the  $n$ -fold convolution of  $F$  (cumulative distribution function) with itself is the distribution of the sum of  $n$  independent random variables each having distribution  $F$  (Ross, 1983, page 17) is denoted by:

$$F * F_{(n-1)*} = F_{n*} \quad (1-53)$$

and also

$$F * F = F_{2*} \quad (1-54)$$

### Example 1-23

Find the probability density function of the sum of the exponentially distributed lifetimes of 3 independent components with parameter  $\lambda$ .

#### Solution

Using convolution:

$$\begin{aligned} g(t) &= [f(t)]_{(n)*} = f(t) * [f(t)]_{(n-1)*} \\ &= \lambda e^{-\lambda t} * [\lambda e^{-\lambda t}]_{(3-1)*} \end{aligned}$$

$$[f(t)]_{(3-1)*} = [f(t)]_{2*}$$

$$[f(a)]_{2*} = \int_{-\infty}^{\infty} f(a-t)f(t)dt \quad a > 0$$

Since the lifetimes are exponentially distributed  $t > 0$  and  $a - t > 0$  ( $\equiv t < a$ ), then  $0 < t < a$  and:

$$[f(a)]_{2^*} = \int_0^a \lambda e^{-\lambda(a-t)} \lambda e^{-\lambda t} dt = \lambda^2 e^{-a\lambda} \int_0^a dt = \lambda^2 a e^{-\lambda a}$$

Continue with convolving  $\lambda^2 t e^{-\lambda t}$  and  $\lambda e^{-\lambda t}$  to reach the solution which is:  $\frac{\lambda}{2} (\lambda a)^2 e^{-\lambda a}$ .

The solution was, because the sum of 3 independent exponential distributions with the same parameter  $\lambda$  has a Gamma distribution with parameters  $(n=3, \lambda)$ .

End of Example ▲

### 1-16 The pdf of the difference of 2 independent and nonnegative random variables

Suppose  $X_1, X_2$  are 2 independent nonnegative random variables with density functions  $f_{X_1}$  and  $f_{X_2}$  and let  $Y=X_2-X_1$ .  $Y$  is sometimes called interference random variable. The density function of  $Y$  is calculated from (extracted from K&L page 125):

$$f_Y(y) = \int_{x_2} f_{X_1}(y+x_2) f_{X_2}(x_2) dx_2 = \begin{cases} \int_{x_2=0}^{\infty} f_{X_1}(y+x_2) f_{X_2}(x_2) dx_2 & y \geq 0 \\ \int_{x_2=-y}^{\infty} f_{X_1}(y+x_2) f_{X_2}(x_2) dx_2 & y \leq 0 \end{cases} \quad (1-55)$$

Needless to say that if the distribution of  $X_2-X_1$  is known There is no need for using The above equation.

## 1-17 Percentage of a distribution being outside limits

To calculate the proportion of a random variable which fell inside and outside any specified limits, let's distinguish 2 cases:

### a) If the distribution of Y is completely known

The calculation is as simple as follows:

For continuous random variable:  $\Pr(a \leq Y \leq b) = \int_a^b f(y) dy$ .

For discrete random variable  $\Pr(a \leq Y \leq b) = \sum_a^b p(y)$ .

where  $f(y)$  and  $p(y)$  are density or probability function of Y.

### b) If the distribution of Y is unknown

In this case Tchebycheff inequality could be used which states that in all statistical distributions the fraction falling outside  $\mu_Y \pm k\sigma_Y$   $k > 1$  is at most  $\frac{1}{k^2}$ :

$$\Pr(|Y - \mu_Y| \geq k\sigma_Y) \leq \frac{1}{k^2}, \quad k > 1 \quad (1-56-1)$$

or

$$\Pr(\mu_Y - k\sigma_Y \leq Y \leq \mu_Y + k\sigma_Y) > 1 - \frac{1}{k^2}, \quad k > 1 \quad (1-56-2)$$

where

$\mu_Y$  and  $\sigma_Y$  are the mean and standard deviation of Y.

### c) A table containing some intervals and frequencies

In this case if the frequency distribution shows the distribution of Y has only one mode and the mode is the same as the arithmetic mean and the frequencies decline continuously on

both side of the mode,(Grant &Leavenworth,1988),according to an adaptation of the above inequality by Camp and Meidel:

$$\Pr(|Y - \mu_y| \geq k\sigma_y) \leq \frac{4}{9k^2} = \frac{1}{2.25k^2}, k \geq 1 \quad (1-57-1)$$

Or

$$\Pr(\mu_y - k\sigma < Y < \mu_y + k\sigma) > 1 - \frac{4}{9k^2}, k \geq 1 \quad (1-57-2)$$

### Example 1-24

The strength of a kind of component is a random variable with  $\hat{\mu}=\bar{X}=40$  . For each of the following cases determine, what percentage of the components fall within the specification limits ( 34, 46).

- 1)The strength is normally distributed with  $\sigma=2$
- 2) the distribution is unknown but  $\sigma=2$
- 3) can the strength in part a be exponentially distribute?
- 4) the distribution is unknown but has one mode and  $\sigma=2$

### Solution

Normal distribution

$$\Pr(a < X < b) = \Pr\left(\frac{a - \mu}{\sigma} < Z < \frac{b - \mu}{\sigma}\right) =$$

$$\Pr\left(\frac{34-40}{2} < Z < \frac{46-40}{2}\right) = \Pr(-3 < Z < 3)$$

From Table C:

$$\Pr(-3 < Z < 3) = 0.99865 - 0.00135 = 0.9973$$



With MATLAB:

$$\Pr(34 < X < 46) = \text{normcdf}(46, 40, 2) - \text{normcdf}(34, 40, 2) = 0.9973$$

That is 99.73% of the product fall within (34 46)

2)Using Tchebychef Inequality:

$$\Pr(\bar{X} - k\sigma < X < \bar{X} + k\sigma) > 1 - \frac{1}{k^2}$$

$$\bar{X} - k\sigma = 34, \quad \bar{X} + k\sigma = 46 \Rightarrow k = 3$$

$$\Pr(40 - 3 \times 2 < X < 40 + 3 \times 2) > 1 - \frac{1}{k^2} = 1 - \frac{1}{3^2} = \frac{8}{9} = \%88.9$$

In this case more than 88.99% of the product fall within 34 and 46.

3)The distribution cannot be exponential because the mean and standard deviation of exponential distribution are equal.

4)Assume the conditions for applying Camp-Meidell inequality holds, therefore :

$$\text{More than } 1 - \frac{1}{2.25k^2} = 1 - \frac{4}{9k^2} \text{ of the product fall within (34 46) ;}$$

or

$$\Pr(34 < X < 46) > 1 - \frac{1}{2.25k^2} = 1 - \frac{1}{2.25 \times 9} = \%95.06 \blacktriangle$$

## Appendix 1 Parameter Estimation Techniques

There many techniques for estimating the parameters of a statistical distribution including the following:

- 1)Maximum Likelihood Estimation(MLE)
- 2)Method of Moments(MOM)

- 3) Least Squares Method (LSE)
- 4) Bayes Method
- 5) Geometric Mean Slope<sup>1</sup>
- 6) Pickands Estimators
- 7) Heuristic Algorithms
- 8) Minimum chi-squared Estimation
- 9) Using Inverse Probability theory
- 10) Bootstrap Estimation Method

From the above methods, MLE and MOM are described briefly below.

## 1-Maximum Likelihood Estimation Method

To use maximum likelihood method, we first need to define likelihood function. Likelihood is a concept that works with joint distributions.

### Definition of Likelihood function

Suppose a random sample  $X_1, \dots, X_n$  has been taken from a continuous or discrete distribution. The following joint probability function  $L$  is called likelihood function:

For continuous distribution:

$$L = f(x_1 \dots x_n) = f_{x_1}(x_1) \cdots f_{x_n}(x_n) \quad (1-58-1)$$

---

<sup>1</sup> Refer to page 25.33 Handbook of Reliability by Irenson et al, 1996

For discrete distribution:

$$L = \Pr(X_1 = x_1, \dots, X_n = x_n) = \Pr(X_1 = x_1) \times \dots \times \Pr(X_n = x_n) \quad (1-58-2)$$

e.g.:

for exponential distribution:

$$L = (\lambda e^{-\lambda x_1}) \dots (\lambda e^{-\lambda x_n}) = \lambda^n e^{-\lambda \sum x_i} \quad (1-58-3)$$

for binomial distribution:

$$L = \prod_{i=1}^k \binom{n}{x_i} p^{\sum_{i=1}^k x_i} \times (1-p)^{\sum_{i=1}^k (n-x_i)} \quad (1-58-4)$$

Notice that the calculation of this method is based on the assumption that  $X_1, \dots, X_n$  are independent and identically distributed(iid).

### Steps of Maximum Likelihood Estimation(MLE) Method

To estimate the parameters  $\theta = \theta_1, \theta_2, \dots, \theta_k$  of a distribution, MLE method could be used through a 3-step process.

1. Find the likelihood function L for the given random variables  $(X_1, X_2, \dots, X_n)$ ,
2. Maximize the likelihood function by taking the derivatives of L with respect to  $\theta$ .

Notice that  $\log(x)$  is a monotone<sup>1</sup>-increasing function of x, maximizing logarithm of a function is equivalent to maximizing the function(based on Barlow and Proshan,1996 p166).

---

<sup>1</sup> A function is monotonic if its first derivative is always positive or negative

Therefore it is often simpler to maximize the logarithm of function  $L$  rather than  $L$  itself (Bowker and Lieberman, 1972 page287)

3. Estimate the value of  $\theta_1, \theta_2, \dots, \theta_k$  by setting the derivatives obtained in Step 2 equal to zero.

Notice that if  $X_1, \dots, X_n$  is random sample from a uniform distribution with  $f(x) = \frac{1}{\theta}$   $\cdot < x < \theta$  it is proved that:

$$MEL(\theta) = \max_{i=1}^n (x_i)$$

### Example 1-25

a) Given a random sample  $X_1, \dots, X_n$  from an exponential distribution, use MLE method to estimate  $\lambda$ .

b) If the sample is (1.1, 0.9, 1.21, 0.8) calculate the value of  $\lambda$ .

### Solution

a) Since the sample is random,  $X_i$  's are independent.

$$L = \lambda^n e^{-\lambda \sum x_i} \Rightarrow \ln L = \ln(\lambda^n e^{-\lambda \sum x_i}) = n \ln \lambda - \lambda \sum x_i \Rightarrow$$

$$\frac{d(\ln L)}{d\lambda} = 0 \Rightarrow MLE(\lambda) = \hat{\lambda} = \frac{n}{\sum x_i} = \frac{1}{\bar{X}}$$

$$b) MLE(\lambda) = \hat{\lambda} = \frac{1}{\bar{X}} = \frac{4}{\sum_{i=1}^4 X_i} = \frac{4}{1.1+0.9+1.2+0.8} = 1 \blacktriangle$$

### Lemma<sup>1</sup>

---

<sup>1</sup> Based on page 290 Bowker & Liberman (1972).

If  $\hat{\theta}$  is the maximum likelihood estimator of  $\theta$  and  $T(\theta)$  is the function of  $\theta$  possessing a single inverse (i.e. its derivative is always positive or negative), then  $T(\hat{\theta})$  is the maximum likelihood estimator of  $T(\theta)$ :

$$MLE [g(\theta)] = g [MLE(\theta)]$$

End of lemma ■

### Example 1-26

If  $X_1, \dots, X_n$  is a random sample of size  $n$ , taken from an exponentially distributed lifetime, estimate  $\theta = \frac{1}{\lambda}$ .

### Solution

Since  $\theta'(\lambda) = \frac{-1}{\lambda^2} < 0$  therefore  $\theta$  has a unique inverse and according to the above lemma:

$$MLE[\theta(\lambda)] = \theta(MLE(\lambda)) = \frac{1}{\bar{X}} = \bar{X}^{-1}$$

### Example 1-27

Given a random sample  $x_1, \dots, x_n$  from a Weibull distribution with location parameter  $A=0$ , use MLE method to derive the relations for calculating the scale and shape parameters  $B$  and  $C$ .

### Answer

$$C = \left[ \frac{\sum_{i=1}^n (x_i^C \ln x_i)}{\sum x_i^C} - \frac{\sum_{i=1}^n \ln x_i}{n} \right]^{-1} \quad (1-59-1)$$

$$B = \left[ \frac{\sum x_i^C}{n} \right]^{\frac{1}{C}} \quad (1-59-2)$$

It is worth mentioning that the MATLAB command `wbfit` estimates the parameters of a Weibull distribution. ▲

### Example 1-28

a) Write a MATLAB code to return the estimates of a 2-p Weibull distribution from which the following sample is available.

b) Also use `wblfit` function to estimate the parameters.

### Solution

a)

```
% Sample X=[X(1).....X(n)]
X=[113.0634 49.5432 53.4872 93.7147 74.0594 114.3216 97.1033
61.5069 74.7216 52.8807];
for C=.01:0.001:40
for I=1:length(X)
LNX(I)=log(X(I));XIC(I)=X(I)^C;XICLN(I)=XIC(I)*LNX(I);
end
A=C-(sum(XICLN)/sum(XIC)-sum(LNX)/length(X))^(1/C);
if abs(A)<= 0.001 )C1=C;disp(sprintf('C= %6.4f', C1)) end
end
B=(sum(X.^C1)/(length(X)))^(1/C1);
disp(sprintf('B= %6.4f ', B))
```

b)

```
>> wblfit(X)
ans = 87.1543 3.7149▲
```

### Example 1-29

Let  $x_i, i=1, \dots, k$  be the number of successes in a sample of size  $n$  from a binomial distribution with parameter  $p$ , Find MLE( $p$ ).

**Solution**

$$L = \prod_{i=1}^k P_{x_i} \quad P_{x_i} = \binom{n}{x_i} p^{x_i} q^{n-x_i}$$

$$L = \prod_{i=1}^k \binom{n}{x_i} p^{x_i} q^{n-x_i} = \binom{n}{x_1} p^{x_1} q^{n-x_1} \times \dots \times \binom{n}{x_k} p^{x_k} q^{n-x_k} \Rightarrow$$

$$L = \prod_{i=1}^k \binom{n}{x_i} \times p^{\sum_{i=1}^k x_i} \times q^{\sum_{i=1}^k (n-x_i)} \Rightarrow$$

$$\ln(L) = \ln\left(\prod_{i=1}^k \binom{n}{x_i}\right) + \ln(p^{\sum_{i=1}^k x_i}) + \ln(q^{\sum_{i=1}^k (n-x_i)}) \Rightarrow$$

$$\ln(L) = \sum_{i=1}^k \ln\left(\binom{n}{x_i}\right) + \sum_{i=1}^k x_i \ln p + \sum_{i=1}^k (n-x_i) \ln(1-p),$$

$$\frac{\partial \ln(L)}{\partial p} = \Rightarrow \frac{\sum_{i=1}^k x_i}{p} - \frac{\sum_{i=1}^k (n-x_i)}{1-p} = \Rightarrow \frac{1-p}{p} = \frac{\sum_{i=1}^k (n-x_i)}{\sum_{i=1}^k x_i} = \frac{nk - \sum_{i=1}^k x_i}{\sum_{i=1}^k x_i} \Rightarrow$$

$$\frac{1-p}{p} = \frac{nk}{\sum_{i=1}^k x_i} - 1 \Rightarrow MLE(p) = \frac{\sum_{i=1}^k x_i}{kn}$$

End of Example ▲

$$k = 1 \Rightarrow MLE(p) = \frac{x}{n}$$

**MATLAB commands for estimating Distributions parameters**

The MATLAB commands for estimating the parameters of some statistical distributions are given in Table H.

For example, given a sample the MATLAB command

expfit returns parameter  $\theta$  for  $f(x) = \frac{1}{\theta} e^{-\frac{x}{\theta}}$ ;

poissfit returns parameter  $\lambda$  of a Poisson distribution

binofit returns parameter  $p$  of a binomial distribution.

### Example 1-30

The following sample shows the lifetime(in year) of some units randomly taken from a batch of a device having an exponentially distributed lifetime. Estimate the parameter of the distribution.

0.04 0.15 0.04 0.09 0.03 0.01 0.04 0.06 0.01 0.15

#### Solution

`X=[0.04 0.15 0.04 0.09 0.03 0.01 0.04 0.06 0.01 0.15]; expfit(X)`

This yields  $\hat{\theta} = 0.062$  which is the mean of the distribution.

Thus  $\hat{\lambda} = \frac{1}{\hat{\theta}} = 16.13$ , which is the average number of annual failures.

### Example 1-30

The annual number of failures of a device has a Poisson distribution; given the following sample estimate the distribution parameter.

17 13 19 8 17 17 12 19 18 19

#### Solution

`>> X=[17 13 19 8 17 17 12 19 18 19];poissfit(X)`

This returns  $\hat{\lambda} = 15.9$ . End of Example▲



### Example 1-30

To estimate the failure probability( $p$ ) of the cables used in the construction of a kind of bridge, 5 samples of size  $n$  from this kind of cable was set to life test. The number of failures in these 5 samples are as follows:

$x_1 = 2, : x_2 = 1, : x_3 = 4, : x_4 = 0, : x_5 = 1$ . What is the maximum likelihood estimate of  $p$ ?

#### Solution

$$k = 5, n = 100, \text{MLE}(p) = \frac{\sum_{i=1}^k x_i}{kn} = \frac{\bar{X}}{n} = \frac{2 + 1 + 4 + 0 + 1}{5 \cdot 100} \Rightarrow$$

$$\text{MLE}(p) = 0.016$$

#### Using MATLAB:

Given  $x_1 = 2, : x_2 = 1, : x_3 = 4, : x_4 = 0, : x_5 = 1$  As seen below, *binofit* function returns 5 estimates with mean of  $\hat{p}=0.016$ .

```
>>x=[2 1 4 0 1]; P=binofit(x,100); phat =mean(P)
phat=0.016.
```

## 2- Methods of Moments(MOM)

A widely used technique in estimation is method of moments .

Before describing the method, it is reminded that:

the  $k^{\text{th}}$  moment of random variable  $X$  about zero(0) is

$E(X^k)$  = expected value of  $X^k$  and  
the  $k^{\text{th}}$  moment about 0 of sample  $x_1, \dots, x_n$  is

$$M_k = \frac{\sum_{i=1}^n X_i^k}{n} .$$

Methods of moments for estimating the parameters of the distribution of random sample  $X$  is based on the fact that the  $k^{\text{th}}$  moment of  $X$  could be estimated by the  $k^{\text{th}}$  sample moment i.e.  $\hat{E}(X^k) = M_k, k=1, 2, \dots$

### Steps of MOM

To estimate parameters  $\theta_1, \dots, \theta_k$  of the statistical distribution of random variable  $X$ ,

i-Compute  $E(X^j), j = 1, \dots, k$  in terms of  $\theta_1, \dots, \theta_k$ .

Notice that always the first moment of a distribution is its mean and the second moment is equal to the variance of the distribution plus the squared mean.

ii-Form the  $k$  equations

$$E(X^j) = M_j, j=1, \dots, k$$

iii-Solve the equations for the parameters  $\theta_1, \dots, \theta_k$ .

The resulting values are called method of moments estimators for the parameters.

**Example 1-32**

Let  $X_1, \dots, X_n$  be a random sample taken from an exponential distribution with parameter  $\lambda$ , Estimate the parameter by the method of moments.

**Solution**

$$E(X) = M_1 \Rightarrow \frac{1}{\lambda} = \frac{\sum X_i}{n} \Rightarrow \hat{\lambda} = \frac{n}{\sum X_i}$$

End of example ▲

**Example 1-33**

Let  $X_1, \dots, X_n$  be a random sample taken from a normal distribution with parameters  $\mu$  and  $\sigma^2$ , estimate the parameters by the method of moments.

**Solution**

$$\begin{cases} E(X) = M_1 \\ E(X^2) = M_2 \end{cases} \Rightarrow \begin{cases} \mu = \frac{\sum X_i}{n} \\ \mu^2 + \sigma^2 = \frac{\sum X_i^2}{n} \end{cases}$$

$$\Rightarrow \begin{cases} \mu = \frac{\sum X_i}{n} \\ \sigma^2 = \frac{\sum X_i^2}{n} - \mu^2 \end{cases} \Rightarrow \begin{cases} \hat{\mu} = \bar{X} \\ \hat{\sigma}^2 = \frac{\sum X_i^2}{n} - \bar{X}^2 \end{cases}$$

In statistics theory it is proved that instead of the above

estimate for variance i.e.  $\frac{\sum_{i=1}^n x_i^2}{n} - \bar{X}^2$  sample variance i.e.

$$S^2 = \frac{\sum_{i=1}^n (x_i - \bar{X})^2}{n-1} = \frac{\sum_{i=1}^n x_i^2 - n\bar{X}^2}{n-1}$$

is a good estimate for the variance of X because of being unbiased i.e.  $\mathbf{E}(S^2) = \sigma^2$ .

## Appendix 2: Application of MATLAB in Reliability theory

Softwares have provided calculations easy. Here some MATLAB functions which might be used in reliability subject is described.

### A-Plotting the frequency distribution of lifetime

Given a sample of the lifetime of a kind of product, the frequency distribution which consists of classes and their corresponding frequencies could be plotted using the following command;

```
>>hist(Data,K)
```

where

Data is a vector consisting the life times of a sample selected at random from a lot of the product,

K is the number of classes into which the range of life time is desired for partitioning.

## B-Parameter estimation

Once the histogram in the above section was prepared one might guess the statistical distribution to which the life times belong. The parameters of this distribution could be estimated using some commands given in Table H at the end of the book e.g.:

To estimate  $\theta$  in an exponential distribution with  $f(x) = \frac{1}{\theta} e^{-\frac{x}{\theta}}$ ,  
`thetahat=expfit(Data)`

To estimate the parameters of a normal distribution:

`[muhat,sigmahat] = normfit(Data)`

To estimate the parameters B and C of a Weibull distribution with reliability function  $e^{-\left(\frac{x-A}{B}\right)^C}$  and A=0:

`BhatandChat= wblfit(data)`

where Data is a vector containing a sample of the life times of the product.

## C-Goodness of fit (GoF)

Goodness of fit implies a comparison of the observed data with the data expected under the model using some fit. It describes how well a statistical model fits a set of observations.

To accomplish this, one could use several GoF tests as well as a kind of graph known as Q-Q plot.

There are a number GoF tests including Pearson chi-squared test for continuous and discrete distributions and Kolmogorov-Smirnov test for continuous distributions. In this section the latter test is introduced.

### C-1 Kolmogorov-Smirnov(KS) test

The Kolmogorov-Smirnov test is used to examine whether a sample comes from a population with a specific CDF  $F(x)$  or not:

$H_0$  The distribution with CDF  $F(x)$  fits the data

$H_1$  CDF  $F(x)$  does not fit the data

The MATLAB function related to this test is as follows:

$H = \text{kstest}(\text{Data}, \text{CDF}, \alpha)$

where

Data A column vector containing data

$\alpha$  Level of significance e.g . 0.05,0.10

CDF hypothesized, continuous cumulative distribution function  $F(x)$

Examples for the format of specifying the desired CDF are given below:

$[\text{Data} \text{ wblcdf}(\text{Data}, \text{A}, \text{B})]$  ,

[Data expcdf (Data,  $\theta$ )],  
 [Data, [Data normcdf(X,  $\mu$ ,  $\sigma$ )].

if omitted or

If the CDF is unspecified (i.e., set to an empty matrix []), the hypothetical distribution is assumed to be a standard normal: N(0,1).

H indicates the result of the test:

$H = 0 \Rightarrow$  Do not reject the null hypothesis at significance level  $\alpha$ .

$H = 1 \Rightarrow$  Reject the null hypothesis at significance level  $\alpha$ .

### Example 1-33

Could it be said that the following sample comes from an exponential distribution with significance level  $\alpha = 0.05$ ?

[110, 520, 645, 680, 330, 75, 95, 480, 360, 575, 1065, 170, 415, 15, 20, 1275, 270, 90, 1500, 1923, 715, 1523, 427, 730, 1120, 390, 240, 40, 220, 673, 2397, 1032, 315]

### Solution

Entering the data as a column vector:

```
>>Data=[...
    110
    520
    ...
    1032
    315];
```

Giving the command:

```
>>H=kstest(Data, [Data expcdf(Data, mean(Data))], 0.05)
```

The answer for H is 0; i.e. it is not rejected that the data belongs to an exponential distribution with significance level  $\alpha = 0.05$ .



## C-2 Q-Q plot

Quantile-quantile ( Q-Q) plot examines the conformity between the empirical distribution and the given theoretical distribution through command **qqplot( X , pd)** which displays the quantiles of the sample data X versus the theoretical quantiles of the distribution specified by the probability distribution object pd:

```
>> X=[...data];  
pd=makedist(distribution name ); e.g.  
pd=makedist ('exponential')  
pd=makedist ('Gamma')  
qqplot(X,pd)
```

Figure1-15 shows a sample Q-Q plot.

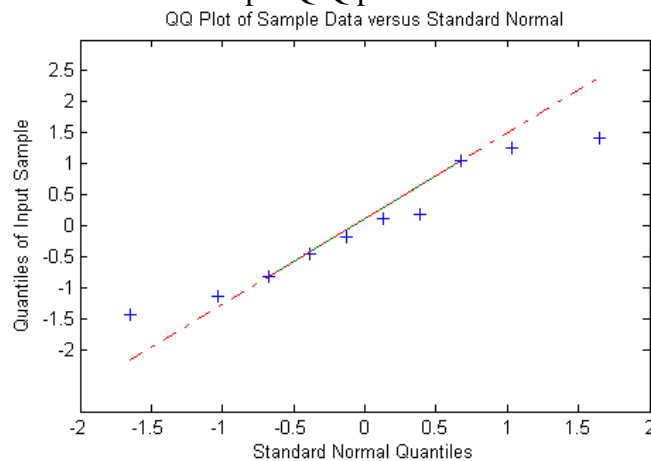

Fig. 1-15 A sample Q-Q plot



The more the points near to the line and the line near to the bisector of the first quarter, the better the distribution fits the data.

#### **D Calculation of Reliability**

Once the distribution of the lifetime of a device is determined to be one of the well-known distributions, the reliability could be easily calculated using the CDF commands in Table H; e.g.

for exponential :

$R=1-\text{expcdf}(x,\theta)$  where  $x$  is mission time and  $\theta$  is the distribution mean,

for normal :

$R = 1-\text{normcdf}(x, \mu, \sigma)$  where  $x$  is the mission time and  $\mu, \sigma$  are the distribution mean and standard deviation.

for 2-parameter Weibull( location parameter  $A=0$ )

$R = 1-\text{wblcdf}(x, B,C)$  where where  $x$  is the mission time and  $B,C$  are the scale and shape parameters of the distribution.

#### **E Calculation of the inverse of cumulative distribution function (CDF )and Reliability function**

The inverse of a CDF gives a value say  $a$  associated with random variable  $X$  such that the probability of the variable being less than or equal ( $X \leq a$ )to  $a$  is equal to the given cumulative probability.

Table H shows the MATLAB command for this purpose. The commands have the suffix *.inv*

### Example 1-34

Suppose the life time( $X$ ) of a device is exponentially distributed with mean of 100 hours,

a) Find  $a$  in  $\Pr(X \leq a) = 0.3935$

answer :

```
>>x=expinv(0.3935,100)
```

```
x=50
```

b) Find the reliability for lifetime equal to 50.

answer

```
>> p=1-expcdf(50,100)
```

```
p = 0.6065
```

c) Find the lifetime value for which the reliability of the device is 0.6065.

```
>>x= expinv(1-0.6065,100)
```

```
x = 50.0051 ▲
```

## **F Finding polynomial roots and Solution of Equations in MATLAB**

During the calculations of problems the following MATLAB commands might be helpful

### **F-1: Finding Roots of Polynomial Equation**

To find the roots of  $a_n x^n + \dots + a_1 x + \dots + a_0 = 0$  the following command in MATLAB is used:

```
>>roots([a_n ... a_1 a_0]).
```

### **F-2: Finding solution of algebraic equations**

*Solve* function in MATLAB finds the solution of an equation of simultaneous equations. For example to find the value of  $\lambda$

which satisfies the equation  $\frac{\int_0^{1/16} \lambda x e^{-\lambda x} dx}{1 - e^{-\lambda(1/16)}} = \frac{1}{128}$ , the following

commands could be used:

```
>>syms landa x; landa =solve((int(landa*x*exp(-landa*x),
x,0,1/16))./(1-exp(-landa/16))=1/128)
```

```
landa=127.65
```

One who brag ,  
will not become savant

## Exercises

1-(Problem 3 Page49 K&L) Two designs for a critical component are being studied for adoption. From extensive testing on prototypes it was found that the time to failure(TTF) is Weibull distributed with a minimum life of zero. Design I costs \$1,200 to build and has Weibull parameters of  $C= 2$  and  $B = 100\sqrt{10}$ . Design II costs \$1500 to build and has Weibull parameters of  $C= 3$  and  $B= 100$  hours,

(a) The component has a 10 hour guaranteed life. Which design should the manufacturer produce and why?

(b) For a 15 hour guaranteed life what should the choice be?

2(Problem 6 Page49 K&L) Consider the piecewise linear bathtub hazard function defined over three regions of interest given below.

$$h(t) = b_1 - c_1 t, \quad 0 \leq t \leq t_1$$

$$h(t) = b_1 - c_1 t_1 - c_2(t - t_1), \quad t_1 < t \leq t_2$$

$$h(t) = b_1 - c_1 t_1 - c_2(t_2 - t_1) + c_3(t - t_2), \quad t_2 < t < \infty$$

The constants  $b$  and  $c$  in the above expressions are determined so that they satisfy the normal requirements for  $h(t)$  to be a hazard function. Find the reliability function based on the above hazard function.

3(Problem 11 Page49 K&L) If  $h(t)$  is a hazard function prove that  $\int_0^{\infty} h(t)dt \rightarrow \infty$ .

4- (Problem 7 Page50 K&L) Which of the following functions can serve as hazard function

a)  $e^{-at}$     b)  $e^{at}$     c)  $ct^{+5}$     d)  $et^{-3}$     e)  $\frac{e^{-2t}}{t^3}$

Develop the density and Reliability functions for those which are hazard function.

5- (Problem 9 Page50 K&L)

50 automobile components are placed on test with a hazard function as below:

$$h(t) = \lambda \cdot t^{-3} \text{ where } t \text{ is in kilometers}$$

Compute the expected number of failures after 10,000 kilometres.

Hint: Let  $X =$  the life time; use binomial distribution with  $n = 50, p = \Pr(X > 10^4)$

6- Repeat the previous Problem for hazard functions

i)  $h(t) = 10^{-6}t$     ii)  $h(t) = 10^{-4} e^{-\frac{2}{100}t}$      $t = km$

7- (Problem 15 Page50 K&L) Given the population distribution is uniform on  $(0, \theta)$ , find the CDF and the pdf for the smallest

extreme value in a random sample of size  $n$ . use the exact theory not the approximation for large  $n$ .

8-(Problem 17 Page50 K&L)Rework the previous problem, assuming  $n$  large and asymptotic distribution of extreme values.

9-If a population is uniformly distributed on  $(\cdot, \theta)$  find the expected value and the variance of the minimum of the samples taken from this distribution.

10-What is the maximum likelihood estimate for parameter  $b$  in Rayleigh distribution with CDF  $F(x)=1-e^{-\frac{x^2}{b^2}}$  ?

11- Write the required relations for estimating the parameters of Bernoulli and normal distributions using MLE method.

12-Assuming  $f(x)$  is a unimodal pdf with modal value  $\tilde{x}$ , prove that  $h'(\tilde{x}) = h^2(\tilde{x})$ .

$$\text{Solution: } h(x) = \frac{f(x)}{R(x)} \Rightarrow h'(x) = \frac{f'(x)R(x) - R'(x)f(x)}{R^2(x)}$$

$$\Rightarrow h'(\tilde{x}) = \frac{f'(\tilde{x})R(\tilde{x}) - R'(\tilde{x})f(\tilde{x})}{R^2(\tilde{x})} = \frac{0 \times R(\tilde{x}) - R'(\tilde{x})f(\tilde{x})}{R^2(\tilde{x})} \Rightarrow h'(\tilde{x}) = \frac{-R'(\tilde{x})f(\tilde{x})}{R^2(\tilde{x})} =$$

$$\frac{-R'(\tilde{x})}{R(\tilde{x})} \times \frac{f(\tilde{x})}{R(\tilde{x})} \Rightarrow h'(\tilde{x}) = h^2(\tilde{x})$$

# Chapter 2

## Static Models

### in

## Reliability

# 2

## Static Reliability Models

### Aims of the chapter

This chapter is concerned with modeling the reliability of the systems in which time coordinate is not presented in the reliability of their subsystems or components. In this regard the chapter after introducing a diagram called reliability block diagram (RBD); deals with some reliability configurations such as series, parallel, k-out-of  $n$  configurations. Furthermore calculation of upper and lower reliability bound for the complex systems is described.

### 2-1 Definition of static reliability models

Here, the word static means that the time coordinate is not presented in the calculations. In modeling a system from a reliability stand point using static models, the component or subsystem reliabilities are considered to be constants; thus some base time period is implied(K&L page 55). Before dealing with some conventional component configurations, a graph is introduced below.



## 2-2 Reliability Block Diagram

A reliability block diagram(RBD) is a graphical model of the elements of a system permitting the calculation of system reliability given the reliability of the elements . Figures 2-1 and 2-2 are RBB examples. Each component or subsystem of the system is presented by a block or box in the RBD. This useful and important graph is used in the calculation of systems' reliability. Now some conventional configurations and their RBDs are addressed below.

### 2-3 series configuration

A series system is one that requires all of its subsystems to function in order for the system itself to function; in other words, it has a configuration such that if any one of the subsystems fails, the entire system fails. Figure 2-1 shows the RBD of a system with series configuration(or simply series system).

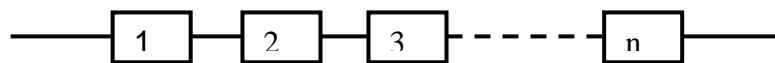

Fig. 2.1 RBD of a series configuration

Let  $E_i$ =event that subsystem  $i$  operates successfully, then the reliability of  $i^{\text{th}}$  subsystem is  $R_i = \Pr(E_i)$  and the system reliability( $R_{\text{sys}}$ ) equals:

$$R_{sys} = Pr(E_1 \cap E_2 \dots \cap E_n).$$

Assuming the operation of the subsystems are independent of each other, we have:

$$R_{sys} = Pr(E_1) \dots Pr(E_n) = R_1 \times \dots \times R_n \Rightarrow$$

$$R_{sys} = \prod_{i=1}^n R_i . \quad (2-1)$$

Since  $0 < R_i < 1$  therefore  $R_{sys} \leq \min_{i=1}^n \{R_i\}$ ; that is the reliability of a series system with independent components is not greater than the least reliable component(K&L page 56). It is worth mentioning that in an n- component series system, if the reliability of all components is equal to  $R_i = 1 - q, i = 1, \dots, n$  then:  $R_{sys} = (1 - q)^n$ . Now notice since according to binomial expansion:

$$(x + y)^n = \binom{n}{0}x^n y^0 + \binom{n}{1}x^{n-1}y^1 + \binom{n}{2}x^{n-2}y^2 + \dots + \binom{n}{n-1}x^1 y^{n-1} + \binom{n}{n}x^0 y^n$$

Therefore

$$(1 - q)^n = 1 + n(-q)^1 + \frac{n(n-1)}{2}(-q)^2 + \dots + (-q)^n$$

Ignoring higher order terms,  $R_{sys}$  could be approximated as follows if  $nq < 1$ :

*Series system:*  $R_{sys} = (1 - q)^n \cong 1 - nq, \quad nq < 1.$

If the components do not have the same reliability and  $i^{\text{th}}$  element failure probability is denoted by  $q_i = 1 - R_i$ , an approximation for the series system reliability is given by (K&L page 58):

$$R_{sys} \cong 1 - \sum_{i=1}^n q_i \quad \sum_{i=1}^n q_i < 1$$

### Example 2-1

A ten-component system with 95% reliability is to be designed. The system is to be designed in such a way that if any component fails the system would fail. What should be the reliability(R) of each component?

### Solution

The system configuration is series and its reliability is :  
 $R_{sys} = (1 - q)^n \quad 0.95 = (1 - q)^{10} \Rightarrow q = 0.0051 \Rightarrow$

$$R = 1 - q = 0.9949$$

Using approximation:

$$R_{sys} \cong 1 - nq \Rightarrow 0.95 = 1 - (10)(q) \Rightarrow q = 0.005$$

$$R = 1 - q = .995 \blacktriangle$$

Notice that if the components are not independent Eq. 2-1 could not be used for computing the reliability of a series system. In this case, the chain rule for factorization, as described below, might be useful:

### Chain Rule for Factorization

Let  $E_i$ =event that subsystem  $i$  operates successfully; then the system reliability( $R_{sys}$ ) equals:

$$R_{sys} = Pr(E_n \cap E_{n-1} \cap \dots \cap E_2 \cap E_1),$$

Using the chain rule for factorization, this joint probability can be rewritten as follows:

$$= Pr(E_n|E_{n-1}, \dots, E_2, E_1)Pr(E_{n-1}|E_{n-2}, \dots, E_1) \dots Pr(E_2|E_1)Pr(E_1)$$

$$= Pr(n^{th} \text{ component is on} | \text{other components are on}) \times \dots \times Pr(1^{st} \text{ component on}) \quad (2-2)$$

## 2-4 Parallel configuration

A system is said to have a parallel configuration if any of the elements in its structure permit the system to function; in other words parallel system is a configuration that works as long as not all of the system components fail.

Assuming the components work independently of one another,

$$Parallel R_{sys} = 1 - (1 - R_1)(1 - R_2) \dots (1 - R_n) = 1 - \prod_{i=1}^n (1 - R_i) \quad (2-3)$$

It could be easily verified that the reliability of a parallel system is more than any of its components reliability.

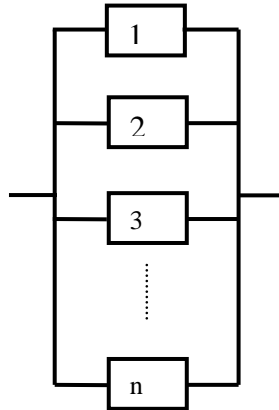

Fig. 2-2 Reliability block diagram of a parallel system-all components working

### Proof of Eq. 3-2

Suppose in a 2-component system, components 1 and 2 are connected in parallel, and let  $E_1$  and  $E_2$  denote the events that 1 and 2 operate successfully. Since the system works if either 1 or 2 works, then the system reliability ( $R_{\text{sys}}$ ) is equal to:

$$R_{\text{sys}} = \text{The probability that either 1 or 2 works} = \Pr(E_1 + E_2)$$

$$\Pr(E_1) = R_1 \quad \Pr(E_2) = R_2$$

$$R_{\text{sys}} = \Pr(E_1 + E_2) = \Pr(E_1) + \Pr(E_2) - \Pr(E_1 E_2) =$$

$$R_1 + R_2 - R_1 R_2 = R_1 + R_2(1 - R_1) =$$

$$1 - (1 - R_1) + R_2(1 - R_1) = 1 - (1 - R_1)(1 - R_2)$$

Or

$$R_{\text{sys}} = 1 - \Pr(\text{both components fail}) = 1 - (1 - R_1)(1 - R_2).$$

And in general if  $n$  components of a system are connected in parallel independent of each other, then the reliability of  $n$ -component parallel system is:

$$R_{sys} = 1 - (1 - R_1)(1 - R_2) \dots (1 - R_n) = 1 - \prod_{i=1}^n (1 - R_i). \quad (2 = 3 - 2)$$

If the unreliability of component  $i$  is denoted by  $Q_i = 1 - R_i$  then:

$$R_{sys} = 1 - Q_1 \dots Q_n. \quad (2 = 3 - 3)$$

End of proof ■

### Example 2-2

a) A 6-component parallel system with a reliability of 80% is to be designed, determine the reliability of each component.

b) How many components in a parallel system leads in a reliability of 99.9% system reliability?

### Solution

$$\begin{aligned} \text{a- } R_{sys} &= 1 - (1 - R)^6 \geq 0.80 \Rightarrow R \geq 1 - (1 - 0.8)^{\frac{1}{6}} = \\ &0.2353 = 23.53\% \end{aligned}$$

$$\text{b- } R_{sys} = 1 - (0.5)^n = 0.999 \Rightarrow n = 10 \blacktriangle$$

### Example 2-3 (K&L page 71)

In an electrical distribution system, electronically operated circuit breakers (CBs) can be activated to interrupt the current. If the current exceeds 105% of the rated line current it is required that the circuit breakers open, thereby disconnecting the supply.

The probability that a circuit breaker functions correctly is 0,98, and each breaker has its own line voltage sensor. If the reliability associated with interrupting the circuit is to be at least 0.999, how many circuit breakers in series are necessary to achieve the desired reliability?

### **Solution**

98% of the times a CB could disconnect the un-allowed current load. To increase the reliability associated with interrupting the circuit, series configuration cannot be used because a series configuration of number of the CBs would result in a reliability of less than 98%; instead a parallel configuration is used, the necessary number of CBs in parallel is calculated as follows:  $R = 1 - (1 - 0.98)^n = .999 \rightarrow n = \log(.001)/\log(.02) \cong 2$  ▲

### **Example 2-3** (from K&L)

A detection system for the CO level in a test cell is under consideration. Specifically, there is a sensor available that will close a circuit and thereby signal the personnel if it detects a particular level of CO concentration. However, this sensor can fail in the following ways:

Failure Statuts	Probability
Signal high CO level when none is present	0.10
Not detect high CO level when it is present	0.15

Obviously, the sensor is not too reliable and it is ecided to use 3 of them ia DC circuit.

(a) Arrange the sensors such that the probability of defecting a high emission level if it is present, is maximized.

(b) Calculate the probability of a false signal for each arrangement considered in (a)

### Solution

a) The reliability of the sensor is:

$$R = 1 - p = 1 - (0.1 + 0.15) = 0.75$$

The reliability of the system is

$$\text{Parallel: } R_{\text{sys}} = 1 - (1 - 0.75)^3 = 0.98$$

$$\text{Series: } R_{\text{sys}} = (0.75)^3 = 0.42$$

Select parallel configuration.

b)

The false signal probability is 0.1, then the probability of false signal in a parallel arrangement is:

$$1 - [1 - (1 - 0.9)^3] = (0.1)^3 = 0.001.$$

Since the probability of without-error operation of the series system is  $(0.9)^3$ ; then the probability of a false signal for series configuration is  $1 - (0.9)^3 = 0.271$ ▲



## **2-4-1 Types of parallel configurations**

In a parallel system the components might be arranged in the following ways;

### **1-Active redundant**

In this parallel configuration more than one components are active and failure of one component still makes the system keep working(Fig 2-2). Eqs. 2-3-1 through 2-3-3 are related to this type of parallel systems.

### **2-Standby redundant**

In this parallel configuration one component works and some similar components are waiting to replace the on-line component when it fails. The system is functional until all components fail. It is worth mentioning that waiting (standby) units might be subject to failure when waiting for replacement.

### **3-Shared parallel configuration**

In the shared parallel system, the failure rate of surviving components increases as failures occur. An automobile wheel assembly is an example of the shared parallel arrangement; if a lug nut comes loose the remaining nuts must support an increased load, and hence the failure rate is increased with each successive failure. Thus, the shared parallel is not truly a static model (K&L page99).

### Definition of Perfect and Imperfect switching

In standby redundant configurations by "perfect switching" it is meant that when the active component fails and a standby component is to replace it by the help of a switch, the switch does not fail during or before replacement operation, mathematically the switch is 100% reliable ( $P_s=1$ ).

"Imperfect switching" refers to the situation in which the switch has a probability of failing to change over from active component A to component B when A fails in a standby redundant configuration.

#### 2-4-1-1 Two-component system with 1 active and 1 standby-Perfect switching

Consider a system composed of an original and a backup component shown in Fig. 2-3. When the original component fails, a perfect switch (i.e. 100% reliable) turns on the standby backup component and the system continues to operate. Let  $R_1, R_2$  denote the reliability of the components.

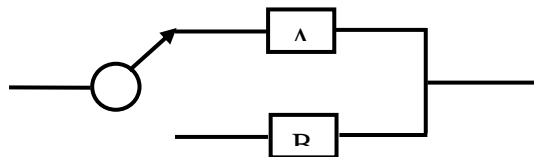

Fig. 2-3 RBD of a 2-component standby system

The reliability of this system is equal to:

$$R_{sys} =$$

$$\begin{aligned} \text{Pr}(\text{system works}) &= \text{Pr}(A \text{ works}) + \text{Pr}(A \text{ does not work}) \times \text{Pr}(B \text{ works}) \\ &= R_1 + R_2(1 - R_1) = R_1 + R_2 - R_1R_2 \end{aligned}$$

Therefore the reliability of a two-component standby system is the same as to that of a 2-component active system as given below:

$$R_{sys}^2 = 1 - (1 - R_1)(1 - R_2) \quad P_{s=1} \quad (2-3-1)$$

#### 2-4-1-2 n-component system with 1 active and n-1 standby-Perfect switching

Consider an n-component standby system with one normally operating subsystem and n-1 in standby status(Fig 2-3-1). The system is functional until n failures occur. The reliability of this system is:

$$\text{standby } R_{sys}^n = 1 - (1 - R_1) \dots (1 - R_n) \quad (2-3-2)$$

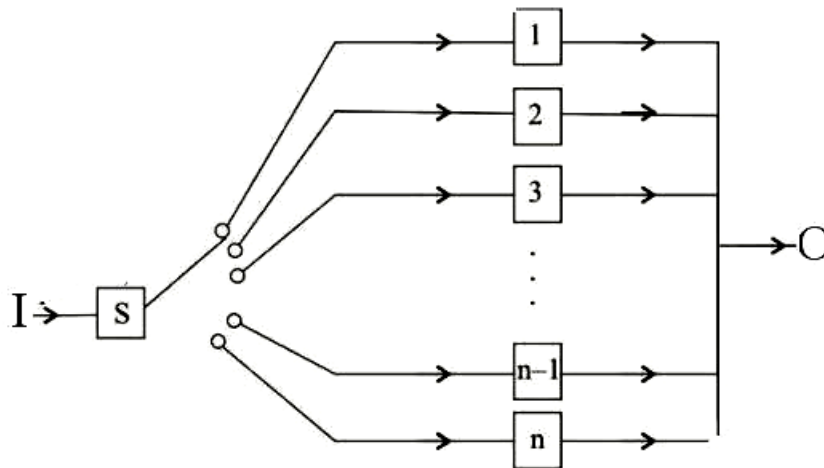

Fig. 2-3-1 RBD of n-component standby system

(<https://egyankosh.ac.in/bitstream/123456789/35169/1/Unit-15.pdf>)

### Proof of Eq. 2-3-2

Suppose a system includes 1 active subsystem and 2 redundant subsystems in standby status with a perfect switch. The

reliability of this system ( $R_{sys}^3$ ) is:

$$\begin{aligned} \text{Stand by} \quad R_{sys}^3 &= 1 - \left\{ 1 - \left[ 1 - (1 - R_1)(1 - R_2) \right] \right\} \{ 1 - R_3 \} \Rightarrow \\ \text{Standby} \quad R_{sys}^3 &= (1 - R_1)(1 - R_2)(1 - R_3) \quad P_s = 1 \end{aligned}$$

This was proof for a 3-component standby system; if the calculations continue in a similar manner for 4-component, 5-component ... standby systems, the result would be Eq. 2-3-2. End of proof ■.

### Example 2-5

A parallel system has an active device with 90% reliability. When this active fails, a perfect switch replaces it by a standby backup with 80% reliability. Calculate the system reliability.

### Solution

$$R_{sys}^2 = 1 - (1 - R_1)(1 - R_2) = 1 - (1 - 0.9)(1 - 0.8) = 0.98 \blacktriangle$$

### 2-4-1-3 Two-component system with 1 active and 1 standby- Imperfect switching

Consider a system composed of an original and a backup component as shown in Fig. 2-3. When the original component fails, an imperfect switch with reliability  $0 < P_s < 1$  turns on the standby backup and the system continues to operate. Let  $R_1, R_2$  denote the reliability of the components in the system  $R_1, R_2$  and  $P_s$  are constants not functions. The redundant component do not share any of the load and is not probable to be in a failure mode before turning on. In this case the system reliability ( $R_{sys}^2$ ) is given by the following relationship (based on

Billinton&Roy,1992 page77 Eq.4-12):

$$R_{sys}^2 = R_1 + P_s R_2 (1 - R_1) = 1 - (1 - R_1)(1 - P_s R_2), \quad P_s < 1 \quad (2-3-3)$$

#### Example 2-6

Evaluate the reliability of the system in Fig. 2-3 if A has the reliability of 0.9, B has a reliability given A has failed of 0.96 and switch has a reliability of 0.98.

#### Solution

$$R_{sys}^2 = 1 - (1 - R_1)(1 - P_s R_2) = 1 - (1 - 0.9)(1 - 0.92 \times 0.96) = 0.9883 \blacktriangle$$

## 2-5 Combination of Series and Parallel Configurations

Some systems have a series-parallel configuration as the ones shown in the following example.

**Example 2-7 :** Consider the series-parallel configurations A&B given below; which one is more reliable? A or B?

A

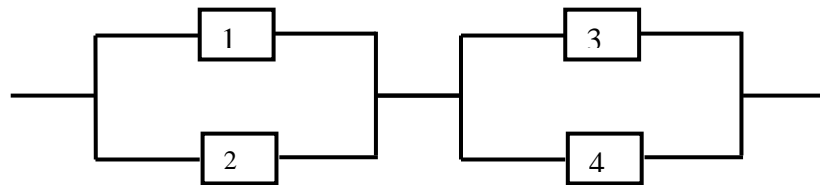

B

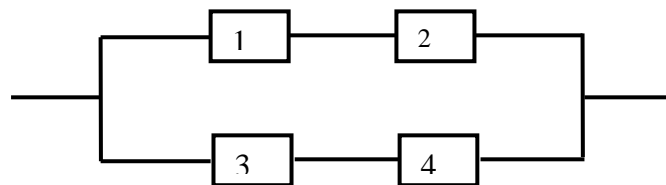

**Solution**

Assuming the components are independent from each other,

$$R_A = [1 - (1 - R_1)(1 - R_2)][1 - (1 - R_3)(1 - R_4)]$$

$$R_B = 1 - (1 - R_1R_2)(1 - R_3R_4)$$

$$R_A - R_B = R_1R_4(1 - R_2)(1 - R_3) + R_2R_3(1 - R_1)(1 - R_4) > 0$$

Then A is more reliable than B. ▲

### Example 2-8

In example 2-7 let  $R_1 = 0.95$ ,  $R_2 = 0.85$ ,  $R_3 = 0.75$ ,  $R_4 = 0.8$  and the components work independent of each other. Calculate the reliability of the configuration.

#### Solution

$$R_A = [1 - (1 - 0.95)(1 - 0.85)][1 - (1 - 0.75)(1 - 0.8)] = 0.9429$$

$$R_B = 1 - (1 - 0.95 \times 0.85)(1 - 0.75 \times 0.8) = 0.9230 \quad \blacktriangle$$

### 2-5-1 Redundancy Level

Redundancy is the duplication of critical components or functions of a system. It is a common approach to improve the reliability and availability a system. In this chapter you were introduced with active and standby redundancies.

One of the most fundamental determinants of component configuration concerns the level at which redundancy is to be provided. Lewis, 1994, Chap. 9). In this regard the following redundancies are introduced:

- ❖ High-level redundancy(HL) or the system level redundancy
- ❖ Low-level(LL) redundancy or the component level redundancy

High-level redundancy involves the duplication of the entire system while low-level redundancy is limited to the duplication of components or subsystems.

**High-level redundancy(HL) or the system level redundancy**

Suppose we have  $n$  types of component and using  $k$  components from each type, a series configuration is formed. If the  $n$  subsystems are connected as a parallel configuration then high-level(HL) redundancy or the system level redundancy has been formed(Fig 2-4-1).

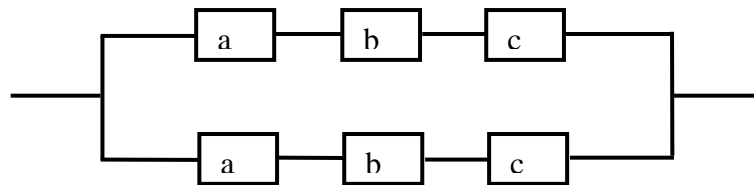

Fig. 2-4-1 Example of High-level(HL) redundancy (Lewis, 1994 p272)

The reliability of the above RBD is;

$$R_{HL} = 1 - [(1 - R_a R_b R_c)]^2$$

**Low-level(LL) redundancy or the component level redundancy**

Suppose we have  $n$  types of component and using  $k$  components from each type, a parallel configuration is formed. If the  $n$  subsystems are connected as a series configuration, then low-level(LL) redundancy or the component level redundancy has been formed(Fig 2-4-2).



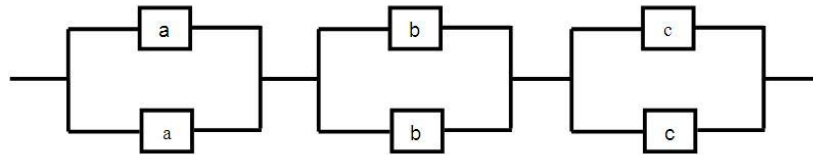

Fig. 2-4-2 Low-level(LL) redundancy (Lewis, 1994 p272)

Remember that if 2 similar components with reliability  $R$  are paralleled then the resulted system would have the following reliability:

$$1 - (1 - R)(1 - R) = 2R - R^2$$

Therefore the reliability of the above RBD is equal to:

$$R_{LL} = (2R_a - R_a^2)(2R_b - R_b^2)(2R_c - R_c^2)$$

If  $R_a = R_b = R_c$  then

$$R_{LL} - R_{HL} = 6R^3(1 - R)^2 > 0 \Rightarrow R_{LL} > R_{HL}.$$

Regardless of how many components the original system has in series, and regardless of whether two or more components are put in parallel, low-level redundancy yields higher reliability, but only if a very important condition is met. The failures must be truly independent in both configurations (Lewis, 1994 page 273)

**Example 2-9**

Find the reliability of a system having the RBD shown in Fig. 2-5-1 in which  $m$  series subsystem of  $n$  components are parallel.

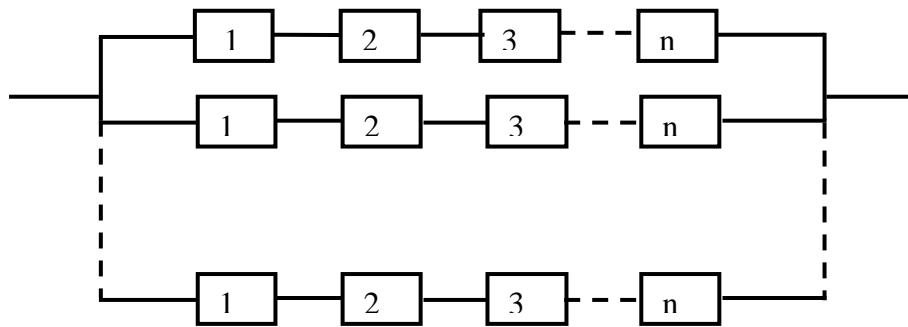

Fig. 2-5-1 The RBD of part *a* of Example 2-9

**Solution** Let  $r_i$  denote the reliability of  $i$ th component for  $i=1,2,\dots,n$ . Then each subsystem reliability is equal to  $\prod_{i=1}^n r_i$ , and the system reliability is given by:

$$R_{sys} = 1 - (1 - \prod_{i=1}^n r_i)^m \quad (2-4-1)$$

where

$m$  number of subsystems

$n$  number of components in each subsystem

$r_i$  the reliability of  $i^{\text{th}}$  component  $i=1,2,\dots,n$

b) Find the reliability of the following system

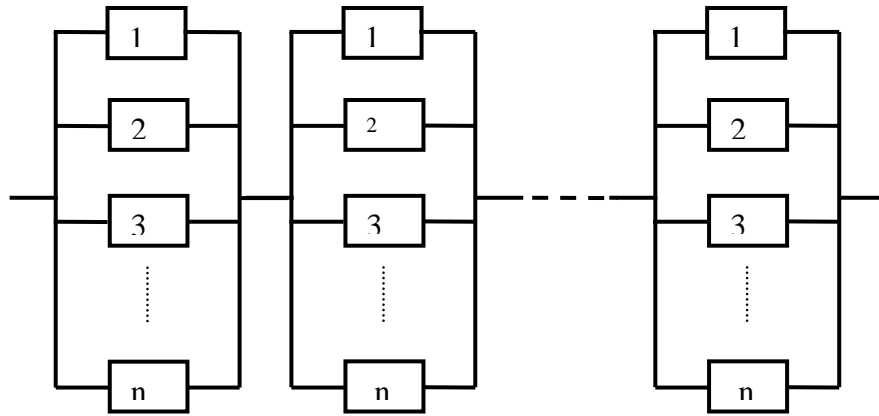

Fig.2-5-2 The RBD of part b of Example 2-9

### Solution

The figure shows that the system has  $m$  parallel subsystems each having  $n$  components. The reliability of this LL redundancy system is given by:

$$R_{sys} = [1 - \prod_{i=1}^n (1 - r_i)]^m \quad (2-4-2) \blacktriangle$$

### Example 2-10 (Lewis, 1994 page271)

Find the reliability of the RBD given in the following figure:

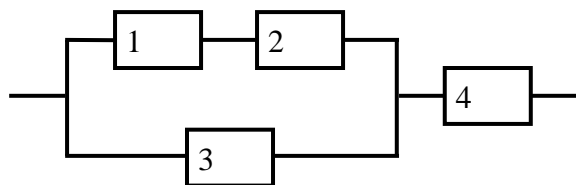

**Solution:**  $R_{sys} = [1 - (1 - R_1 R_2)(1 - R_3)](R_4)$  ▲

### Example 2-11

In the following 2-component system, the reliability of the components are respectively  $R_1, R_2$ . If the reliability of this system is not enough for us, and we have the following two options to use, which one has more reliability? A or B?

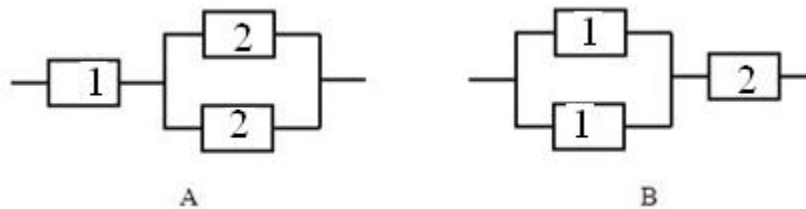

### Solution

$$R_A = R_1(R_2 + R_2 - R_2^2)$$

$$R_B = [R_1 + R_1 - (R_1)(R_1)](R_2)$$

$$R_B - R_A = (R_1 R_2)(R_2 - R_1)$$

Therefore if  $R_2 > R_1$ , configuration B would be more reliable than configuration A ▲.

Not surprisingly, this expression indicates that the greatest reliability is achieved in the redundant configuration if we duplicate the component that is least reliable; if  $R_2 > R_1$  then system B is preferable, and conversely. This rule of thumb can be generalized to systems with any number of non-redundant components; the largest gains are to be achieved by making the least reliable components redundant (Lewis, 1994 page 271).

## 2-6 k-out-of-n configuration

A k-out-of-n system has n identical independent components or subsystems, of which only k need to be functioning for system success (Fig. 2-6). It is supposed that each component works, independently of all the other components ..

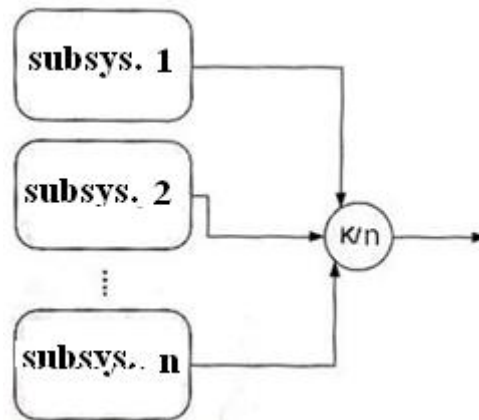

Fig 2-6 A k-out-of-n system

### examples of real world applications

Applications of k-out-of-n systems can be found in many areas such as communication, electric and electronic, safety monitoring systems and human organizations.

In a cable-supported bridge having n supporting cables, at least k cables must be working

A committee with n members who must decide to accept or reject innovation-oriented projects and the committee will accept a project when k or more member (Nordmann and Pham 1999)

### 2-6-1 Reliability of k-out-n configuration

In k-out-of-n configuration, if k=1 the configuration is active parallel configuration with the following reliability:

$$R_a = 1 - (1 - R_1) \dots (1 - R_n)$$

If k=n, the configuration would be:

$$R_{series} = R_1 \times \dots \times R_n$$

If k=n-1, the system does not fail with the failure of one component, but it fails with the failure of 2 components.

In the simplest form, let the reliability of all components be the same and equal to R. To compute the reliability of this k-out-of system notice that (Lewis, 1994 page 269):

For identical components, the reliability of an k-n system may be determined by the binomial distribution. Suppose that p is the probability of failure over some period of time for one unit. That is,  $p = 1 - R$ , where R is the component reliability.

From the binomial distribution the probability that n units will fail is just

$$Pr(X = x) = \binom{n}{x} p^x (1 - p)^{n-x}$$

The n-k system will function if there are no more than n-k failures. Thus the reliability is as follows:

$$Pr(X \leq n - k) = \sum_{x=0}^{n-k} \binom{n}{x} p^x (1 - p)^{n-x}$$

Substituting 1-R for p yields;

$$R_{sys} = \sum_{x=0}^{n-k} \binom{n}{x} (1 - R)^x (R)^{n-x} \quad (2-5)$$

with MATLAB:

$$R_{sys} = \text{binocdf}(n - k, n, 1 - R) \quad (2-5-1)$$

The system failure probability or system unreliability is calculated

from:

$$1 - R_{sys} = 1 - \text{binocdf}(n - k, n, 1 - R)$$

Alternatively,

we could say that system work as far as n-k components out of n component fail. Then the probability of system failure is given by:

$$Pr(X > n - k) = \sum_{x=n-k+1}^n \binom{n}{x} p^x (1 - p)^{n-x}$$

Then the system reliability ( $R_{sys}$ ) is;

$$R_{sys} = 1 - \sum_{x=n-k+1}^n \binom{n}{x} (1 - R)^x R^{n-x}$$

Or we could say that system work as far as k components out of n component work. Then the reliability of system is given by:

$$R_{sys} = \sum_{i=k}^n \binom{n}{i} R^i (1 - R)^{n-i}$$

where R is component reliability.

This relationship and the following integral are equal(Barlow & proshan,1998 page218):

$$R_{sys} = k \binom{n}{k} \int_0^R x^{k-1} (1-x)^{n-k} dx.$$

In summary, if the reliability of components in a k-n system is denoted by R then:

$$R_{sys} = \sum_{i=k}^n \binom{n}{i} R^i (1-R)^{n-i} = k \binom{n}{k} \int_0^R x^{k-1} (1-x)^{n-k} dx. \quad (2-6)$$

where

R	component reliability
$R_{sys}$	system reliability
n	Total number of components in the system
i	no. of components that work
n-i	no. of components that fail

using MATLAB:

$$R_{sys} = 1 - \text{binocdf}(k-1, n, R) \quad (2-6-1)$$

Notice that Eqs. 2-5 and 2-6 are equal.

### Example 2-12

A system has a 3 out of 5 active redundancy configuration. The reliability of each component is  $R=0.9$ . Calculate the reliability of the system.

#### Solution

Using integral of Eq. 2-6:

$$R_{sys} = 3 \binom{5}{3} \int_0^R x^{3-1} (1-x)^{5-3} dx = 6R^5 - 15R^4 + 10R^3$$

$$R=0.9 \Rightarrow R_{sys}=0.99144$$

Using  $\Sigma$  in Eq. 2-6:



$$R_{\text{sys}} = 1 - \sum_{i=0}^{k-1} \binom{n}{i} R^i (1-R)^{n-i} = 1 - \sum_{i=0}^{3-1} \binom{5}{i} 0.9^i (1-0.9)^{5-i}$$

With Matlab:

Eq. 6-2

$$3 * \text{nchoosek}(5,3) * \text{int}(R^2 * (1-R)^2) = 6R^5 - 15R^4 + 10R^3$$

Eq. 2-5-1

$$\text{binocdf}(n-k, n, 1-R), R_{\text{sys}} = \text{binocdf}(5-3, 5, 1-.9) = 0.9914$$

Eq. 2-6-1:

$$R_{\text{sys}} = 1 - \text{binocdf}(2, 5, 0.9) = 1 - 0.00856 = 0.99144$$

End of Example ▲

### Example 2-13

The system shown in the following figure has only 4 components  $A_1, A_2, A_3$  and  $A_4$ . Each component works, independently of all the other components. Determine the configuration of the system.

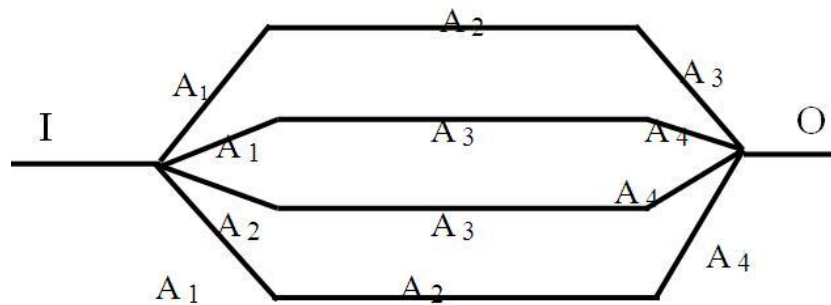

**Solution**

It is evident from the figure that the system works in the following conditions:

If  $A_1, A_2$  &  $A_3$  work,

If  $A_2, A_3$  &  $A_4$  work,

If  $A_1, A_3$  &  $A_4$  work,

If  $A_1, A_2$  &  $A_4$  work,

If  $A_1, A_2, A_3$  &  $A_4$  work.

Therefore the system works if at least 3 components work; i.e.

the system has a  $k=3/n=4$  configuration. End of Example▲

**Example 2-14**

The system shown in the following figure has only 3 components 1,2 and 3. Each component works, independently of the two others. Determine the configuration of the system.

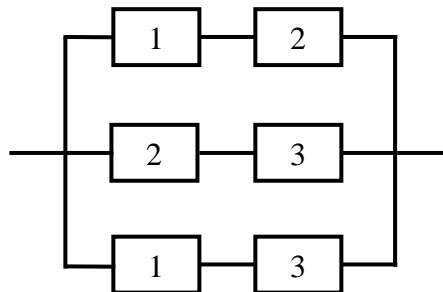
**Solution**

It is evident from the figure that the system works in the following conditions:

If 1 & 2 work,

If 1 & 3 work,

If 2 & 3 work,

If all 3 components work.

That is at least 2 components out of 3 must work in order to have a working system. Therefore the system has a 2-out-of-3 configuration. ▲

### Example 2-15

Verify that a k-out-of-n configuration converts to a series configuration for k=n and reduces to parallel configuration for k=1.

### Solution

According to Eq. 6-2, the reliability of a k/n system is:

$$R_{sys} = \sum_{i=k}^n \binom{n}{i} R^i (1-R)^{n-i}$$

substituting k=n:

$$R_{sys} = \sum_{i=n}^n \binom{n}{i} R^i (1-R)^{n-i} = \binom{n}{n} R^n (1-R)^{n-n} = R^n$$

$$k = n \Rightarrow R_{sys} = R^n$$

substituting k=1:

$$R_{sys} = \sum_{i=1}^n \binom{n}{i} R^i (1-R)^{n-i}$$

$$R_{sys} = \sum_{i=0}^n \binom{n}{i} R^i (1-R)^{n-i} - \binom{n}{0} R^0 (1-R)^{n-0} \Rightarrow$$

$$R_{sys} = \sum_{i=0}^n \binom{n}{i} R^i (1-R)^{n-i} - (1-R)^n$$

According to Newton binomial expansion:

$$(a + b)^n = \sum_{x=0}^n \binom{n}{x} (a)^x b^{n-x}$$

then

$$\sum_{x=0}^n \binom{n}{x} (1 - R)^x R^{n-x} = (1 - R + R)^n = 1^n = 1$$

therefore

$$R_{sys} = \sum_{i=0}^n \binom{n}{i} R^i (1 - R)^{n-i} - (1 - R)^n = 1 - (1 - R)^n$$

i.e. for  $k=1$   $k/n$  configuration reduces to parallel configuration.

End of Example ▲

### 2-6-1-1 Upper bound for k-out-of-n reliability

The reliability of  $k/n$  configuration is given by Eq. 5-2 :

$$R_{sys} = \sum_{x=0}^{n-k} \binom{n}{x} (1 - R)^x (R)^{n-x}$$

Then

$$\begin{aligned} R_{sys} &= 1 - \sum_{x=n-k+1}^n \binom{n}{x} (1 - R)^x (R)^{n-x} \\ &= 1 - \binom{n}{n-k+1} (1 - R)^{n-k+1} (R)^{n-(n-k+1)} \\ &\quad - \binom{n}{n-k+2} (1 - R)^{n-k+2} (R)^{n-(n-k+2)} - \dots \end{aligned}$$

Then

$$R_{sys} \leq 1 - \binom{n}{n-k+1} (1 - R)^{n-k+1} \quad (2-7)$$

This is an upper bound for the reliability of a  $k$ -out-of- $n$  configuration.

### Example 2-16

A pressure vessel is equipped with 6 relief valves that work independent of each other. Three valves are enough for the safe operation of the vessel. The failure probability of each valve is 0.1%. Calculate the probability of safe working of the vessel.

#### Solution

The reliability of this system, which has a 3-out-of-6 reliability configuration, is given by Eq. 2-6-1:

$$R = 1 - 0.001 = 0.999$$

$$R_{sys} = 1 - binocdf(k - 1, n, R)$$

$$1 - binocdf(2, 6, 0.999) = 0.99999999998502$$

The probability of failure (unreliability probability):

$$1 - R_{sys} \cong 1.4976 \times 10^{-11}. \text{End of Example } \blacktriangle$$

#### Notice that:

In Reliability literature related to k-out-of-n configuration sometimes the binary variables  $c_i$  and  $\eta$  are defined as:

$$c_i = \begin{cases} 1 & \text{if component } i \text{ is functioning} \\ 0 & \text{otherwise} \end{cases}$$

i.e. The structure of the  $i^{\text{th}}$  component is described by this binary variable.

$$\eta = \begin{cases} 1 & \sum_{i=1}^n c_i \geq k \\ 0 & \sum_{i=1}^n c_i < k. \end{cases}$$

The binary variable  $\eta$  indicates the state of the k/n system.

These binary variables might be used in the optimization problems related to k/n systems.

## 2-7 Complex System Analysis

Not all designs can easily be tackled for reliability computations. Certain designs such as those shown below are so complex that pure parallel or series are not appropriate for the calculation of their reliability. Such systems are known as complex systems. There are some methods for calculating the reliability of complex system including:

- a) Enumeration method
- b) Path Tracing
- c) Conditional Probability Method or Application of Bayes theorem or Conditioning on a key element
- d) Delta-Star Transformation Approach for Reliability Evaluation
- e) Method based on Markov chain
- f) Cut and tie set analysis

Methods c, d and f are described below.

### **2-7-1 Conditional Probability Method**

To evaluate the reliability of a complex system using conditional probability approach or the decomposition method , follow the steps explained below:

1. Choose a component, say K, which appears to bind together the reliability of the system as a keystone component. A poor choice may increase the number of steps in the calculations.

2. Decompose the original system first by considering the keystone component to be working all the time, which means is 100% reliable. Secondly, consider it as not working (which means that it is not reliable at all or has failed). Prepare 2 new RBDs as reduced subsystems:

in the first one, replace the working K by a line in the reliability block diagram of the original RBD. This means that the information can flow in either direction with no interruption.

For preparing the other subsystem remove component K from the RBD of the original system. This is because if component K does not work, it means that the path(s) of information which goes/go through component K is/are interrupted. Hence, information cannot pass through component K

3) Calculate the reliabilities of the reduced subsystems and then calculate the reliability of the system ( $R_{\text{sys}}$ ) from:

$$R_{\text{sys}} = \Pr(\text{system success} \mid \text{component K is working}) + \Pr(\text{system success} \mid \text{component K does not work at all})$$

It is worth explaining that this method has been extended to choosing more than one key element. For more details refer to references such as Wang & Jiang(2004).

**Example 2-17**(Lewis,2014Page 281)

Calculate the reliability of a system with the following RBD:

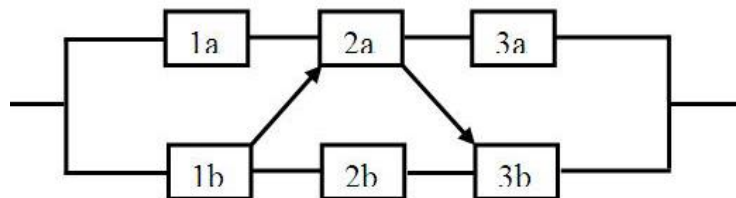

**Solution**

Component 2a is chosen as the key element and system operation is conditioned on:

- i) 2a works all the time
- ii) 2a does not work at all

With the following symbols :

- Y The event that the original system works successfully
- x The event that Component 2a fails



$\bar{X}$  The event that Component 2a works

$R_1$  The reliability of Components 1a&1b

$R_2$  The reliability of Components 2a&2b

$R_1$  The reliability of Components 3a&3b

The sample space(SS) includes 2 events:  $SS = \{\bar{X}, X\}$ .

Applying Bayes theorem:

$$Pr\{Y\} = Pr(Y|X)Pr(X) + Pr(Y|\bar{X})Pr(\bar{X}) \quad (2-8)$$

Let  $Pr\{X\} = R_1$      $Pr\{\bar{X}\} = R_2$

Then  $Pr\{X\} = 1 - R_2$  and and Eq. 2-8 is could be written as:

$$R = Pr(Y) = R^-(1 - R_2) + R^+R_2 \quad (2-9)$$

Now, we must evaluate the conditional reliabilities  $R^+$  and  $R^-$ .

For  $R^-$  in which 2a has failed, all paths leading through 2a in the original RBD are disconnected. The resulting RBD is as follows:

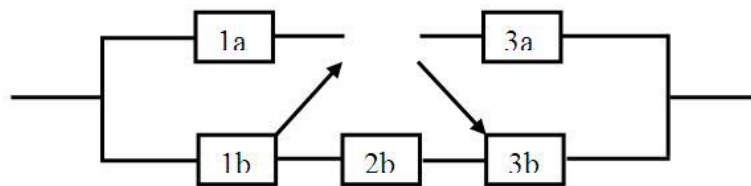

This reduced system forms a series configuration of components 1b, 2b and 3b then:

$$R^- = Pr(Y|X) = R_1R_2R_3$$

Conversely, for  $R^+$  in which 2a is operational a line is drawn instead of 2a. This action bypasses component 2b.

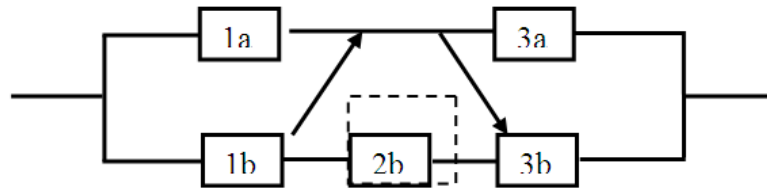

Therefore in this case the resulting RBD appears as follows:

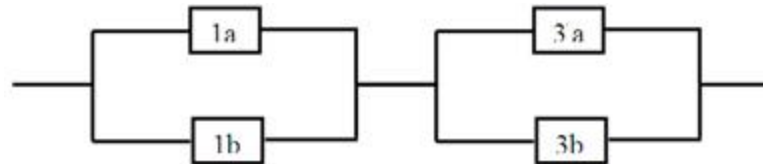

which has the following reliability

$$R^+ = Pr(Y|\bar{X}) = [1 - (1 - R_1)^2][1 - (1 - R_3)^2]$$

Substituting the expressions for  $R^-$  and  $R^+$  into Eq. 2.8, the reliability of the original system is as follows:

$$R = R_1 R_2 R_3 (1 - R_2) + [1 - (1 - R_1)^2][1 - (1 - R_3)^2](R_2) \quad (10-2)$$

### 2-7-2 Delta-Star Transformation Approach for Reliability Evaluation

In this section, the reader is presented with the so-called delta configuration and star configuration, delta-Star conversion and the use of this transformation to simplify complex reliability block diagrams.

Figure 2-7 shows the star and delta configurations. Here we use the capital letter R for the reliability of each component of star connections and lower case r for that of delta configuration. Capital letter V stands for vortices.

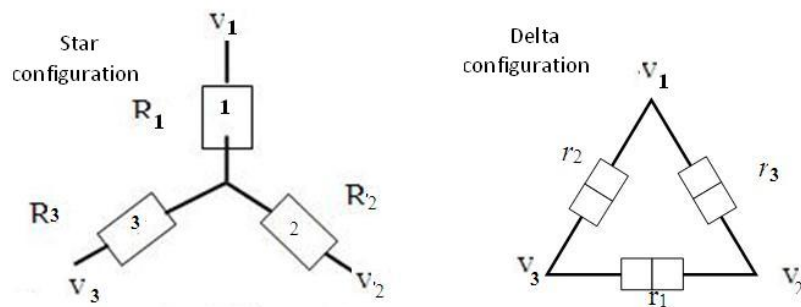

Fig. 2.7 Star and delta configurations

Delta- Star transformations help us to transform some reliability networks into series parallel networks. This is dealt below.

### 2-7-2-1 Transforming a delta configuration into an equivalent star configuration (Grosh,1989 Page137)

Suppose a delta configuration is completely known and given in Fig 2-7 and we would like to find a star configuration which has the same reliability. The reliability equivalence of the 2 configurations in Fig. 2-7 requires that:

1)The reliability of the section between vortices \$V\_1\$ and \$V\_2\$ in star configuration (\$R\_1\$ in series with \$R\_3\$) must be equivalent to the reliability of same section in delta configuration (subsystem \$r\_2\$ in parallel with "\$r\_3\$ in series with \$r\_1\$"); i.e.

$$R_3 R_1 = 1 - (1 - r_3 r_1)(1 - r_2) = C = r_2 + r_1 r_3 - r_1 r_2 r_3$$

2) With a similar argument for vortices 1 & 2, we could write :

$$R_1 R_2 = 1 - (1 - r_1 r_2)(1 - r_3) = A = r_3 + r_2 r_1 - r_1 r_2 r_3$$

3) Similarly:

$$R_2 R_3 = 1 - (1 - r_2 r_3)(1 - r_1) = B = r_1 + r_2 r_3 - r_1 r_2 r_3$$

### The equivalent star configuration:

Solving the above 3 equations simultaneously for  $R_1, R_2, R_3$  would result in:

$$\left. \begin{array}{l} 1 \left\{ \begin{array}{l} R_1 = \frac{\sqrt{ABC}}{B} \quad (2-10-1) \\ R_1 = \frac{\sqrt{[1 - (1 - r_2)(1 - r_3 r_2)][1 - (1 - r_1)(1 - r_2 r_1)][1 - (1 - r_1)(1 - r_3 r_1)]}}{1 - (1 - r_1)(1 - r_2 r_3)} \end{array} \right. \\ 2 \left\{ \begin{array}{l} R_2 = \frac{\sqrt{ABC}}{C} \quad (2-10-2) \\ R_2 = \frac{\sqrt{ABC}}{A} \quad (2-10-3) \end{array} \right. \\ 3 \left\{ \begin{array}{l} R_3 = \frac{\sqrt{ABC}}{A} \quad (2-10-3) \\ A = 1 - (1 - r_1 r_2)(1 - r_3) \quad B = 1 - (1 - r_2 r_3)(1 - r_1) \\ C = 1 - (1 - r_3 r_1)(1 - r_2) \end{array} \right. \end{array} \right.$$

### Example 2-18

Suppose the components of the delta configuration in Fig 2.7 has the following reliabilities  $r_1=0.7$  ,  $r_2=0.8$  ,  $r_3=0.9$ . Find the equivalent star configuration.

**Solution**

$$R_1 = \frac{\sqrt{ABC}}{B} \quad R_2 = \frac{\sqrt{ABC}}{C} \quad R_3 = \frac{\sqrt{ABC}}{A}$$

$$A = 1 - (1 - r_1 r_2)(1 - r_3) = 1 - (1 - r_3 - r_1 r_2 + r_1 r_2 r_3) = 0.956$$

$$B = 1 - (1 - r_2 r_3)(1 - r_1) = 0.916$$

$$C = 1 - (1 - r_3 r_1)(1 - r_2) = 1 - (1 - r_2 - r_1 r_3 + r_1 r_2 r_3) = 0.926$$

$$\sqrt{ABC} = 0.900497 \quad R_1 = \frac{0.900497}{0.916} = 0.9831$$

$$R_2 = \frac{0.900497}{0.926} = 0.9725 \quad R_3 = \frac{0.900497}{0.956} = 0.9419 \quad \blacktriangle$$

**2-7-2-3 Transforming a star configuration into an equivalent delta configuration**

In this section  $r_1, r_2, r_3$  have to be found from the 3 equations of Sec. 2-7-2-3 in terms of  $R_1, R_2, R_3$ . The following MATLAB code could be used to do this:

```
% Star2Delta.m
clc;
clear;
close all;
% Parameters input
R1=input('Please Insert R1 value in Y config: ');
R2=input('Please Insert R2 value in Y config: ');
R3=input('Please Insert R3 value in Y config: ');
global A B C;
A=R1*R2;
B=R2*R3;
C=R1*R3;
```

```
%% calculations
options=optimset('Display','Off');
Eq=fsolve(@Delta,[0.5,0.5,0.5],options);

Eq1=Eq(1);
Eq2=Eq(2);
Eq3=Eq(3);
display(['r1= ' num2str(Eq1), ' r2= '
num2str(Eq2), ' r3= ' num2str(Eq3)])
The sub-code Delta.m used above is as follows:
```

```
function W=Delta(r)
global A B C;
W=[1-(1-r(1)*r(2))*(1-r(3))-A;
1-(1-r(3)*r(2))*(1-r(1))-B;
1-(1-r(1)*r(3))*(1-r(2))-C];
```

### Performing star2Delta using the data in Example 2-11

```
>>star2Delta
Please Insert R1 value: 0.9831
Please Insert R2 value: 0.9725
Please Insert R3 value: 0.9419
Results: r1= 0.69991    r2= 0.79993    r3= 0.90017
```

### Special case: identical components

If a delta configuration consists of 3 identical component with a reliability of  $r_{\Delta}$ ; the equivalent star configuration must have the following components:

$$R_1 = R_2 = R_3 = \sqrt{-r_{\Delta}^3 + r_{\Delta}^2 + r_{\Delta}} = R_Y \quad (2-11)$$

Conversely a star configuration with identical components  $R_Y$  has an equivalent delta configuration in which all its 3 components has the reliability  $r_{\Delta}$  obtained from the following:

$$-r_{\Delta}^3 + r_{\Delta}^2 + r_{\Delta} - R_Y^3 = 0 \quad (2-12)$$

### Example 2-19

In a delta configuration the reliability of the 3 subsystems is  $r_{\Delta}=0.9$ . Find the equivalent star configuration.

### Solution

$$R_Y = \sqrt{-r_{\Delta}^3 + r_{\Delta}^2 + r_{\Delta}} = 0.99045 \text{ i.e. } R_1 = R_2 = R_3 = R_Y = 0.99045$$

Conversely if Eq. 2-12 is solved with  $R_Y = 0.99045$ ,

$-r_{\Delta}^3 + r_{\Delta}^2 + r_{\Delta} - 0.99045^2 = 0$  would give 3 answers (-0.995, 1.0952 and 0.9) for  $r_{\Delta}$ , the acceptable answer is  $r_{\Delta} = 0.9$ .

End of Example ▲

The following example illustrates the delta-star transformation approach for reliability evaluation of complex systems.

### Example 2-19

A system has the following RBD. The components work independent of each and the reliability of %90. Find the reliability of the system.

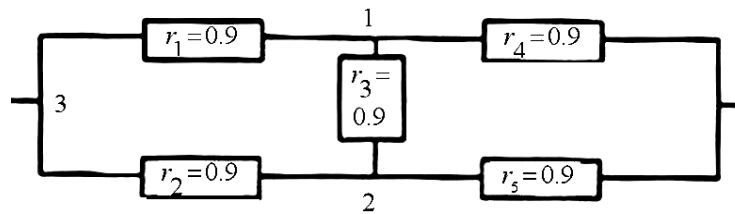

**Solution No.1:** star-delta approach

The vortices 1,2 and 3 in the given RBD constitute a delta configuration. The equivalent star configuration has 3 components with the following reliabilities:

$$R_1 = \frac{\sqrt{ABC}}{B} \quad R_2 = \frac{\sqrt{ABC}}{C} \quad R_3 = \frac{\sqrt{ABC}}{A}$$

where

$$A = B = C = 1 - [1 - (0.9)(0.9)](1 - 0.9) = 0.981$$

$$R_1 = R_2 = R_3 = \frac{\sqrt{0.981^3}}{0.981} = 0.9904$$

Replacing the delta configuration with this star configuration

would yield the following equivalent RBD for the system



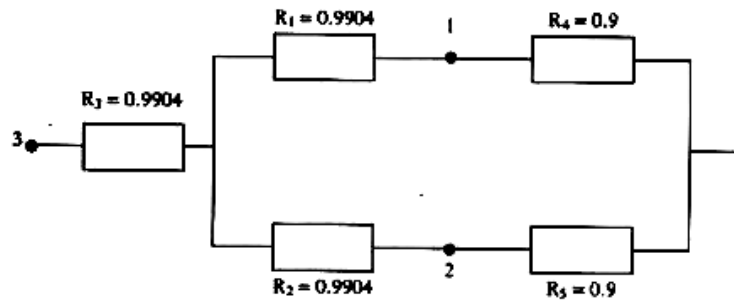

The reliability of the system based on the new RBD is calculated as follows:

$$R_{\text{Sys}} = 0.9904 \times (1 - (1 - 0.9904 \times 0.9) (1 - 0.9904 \times 0.9)) = 0.9787.$$

### Solution No.2 Conditional Probability Approach

The Element No 3 is chosen as the key element. If this element is not functional, the following RBD with a reliability denoted by  $R_{SP}$  would be obtained.:

$$R_{SP} = 1 - (1 - 0.9 \times 0.9)(1 - 0.9 \times 0.9) = 0.9639$$

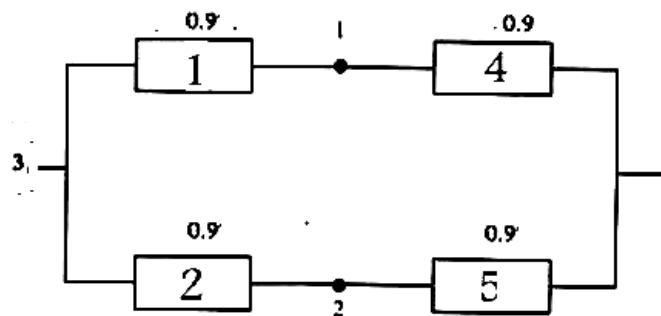

Suppose Element No. 3 in the original RBD works all the time. Replacing it with a line would result the following RBD with a reliability denoted by  $R_{PS}$ .

$$R_{PS} = [1 - (1 - 0.9)(1 - 0.9)][1 - (1 - 0.9)(1 - 0.9)] = 0.9801$$

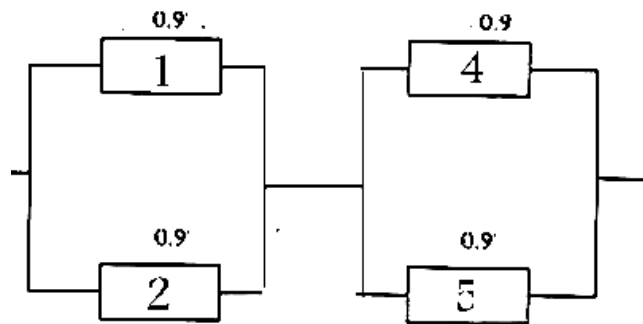

Now  $R_{sys}$  (the reliability of the system) is calculated using Bayes Rule (Eq. 2-8) as follows:

$$R_{sys} = R_{SP} \times (1 - r_3) + R_{PS} \times r_3 = 0.9639 \times 0.1 + 0.9801 \times 0.9 = 0.9785 \quad \blacktriangle$$

## 2-8 Calculation of upper and lower bounds for complex system using cut and tie set analysis

In this section a procedure is introduced for calculating an upper and a lower reliability bound for complex systems. This procedure is based on the so-called tie and cut sets. The RBS of some complex systems are shown below.

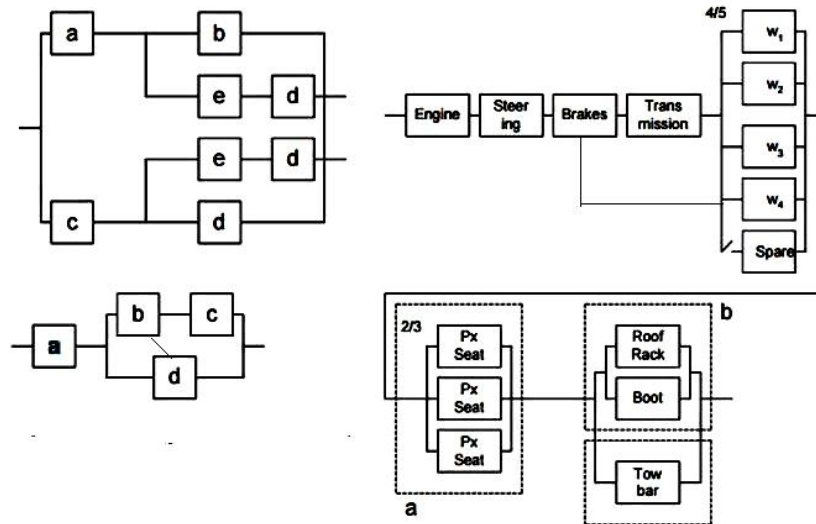

Fig. 2-9 Three complex systems

Before performing the calculations, some definitions are introduced:

### Definition of minimal cut set

This set is a minimal set of components which by failing guarantee the failure of the system (Grosh, 1989 page 125); in other words the failure of its components cause interruption of all paths from the input to the output of the system.

### Definition of minimal path

A minimal path is a minimal set of components by functioning ensures the system operation (Grosh, 1989 page 125).

Notice that

-Each complex system has usually several minimal path and cut sets. A set could be both cut and path.

- In the foregoing discussion, by mentioning cut set, minimal cut set is meant and by mentioning path set, minimal path set is meant.

**Example 2-21** (Grosh, 1989 page 125)

Find the minimal path and cut sets for the following RBD.

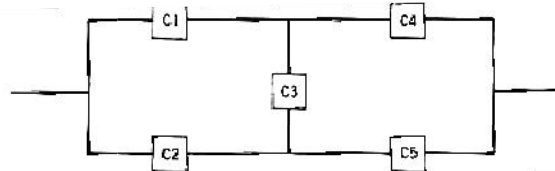

**Solution**

The minimal cut sets are:

Cut set no.	components
1	$C_1C_2$
2	$C_4C_5$
3	$C_1C_3C_5$
4	$C_2C_3C_4$

The minimal path are:

Cut set no.	components
1	$C_1C_4$
2	$C_2C_5$
3	$C_1C_3C_5$
4	$C_2C_3C_4$

End of Example▲

**Example 2-22**(O'connor,2003 page175)

The RBD of a system is given below. Show the minimal cut and path sets on the RBD.

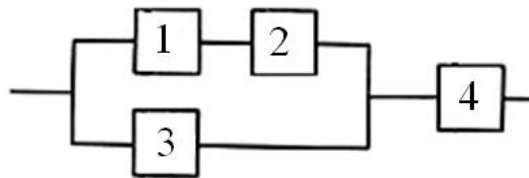

**Solution**

The minimal cut sets are (1-3 2-3 and 4 )as shown below:

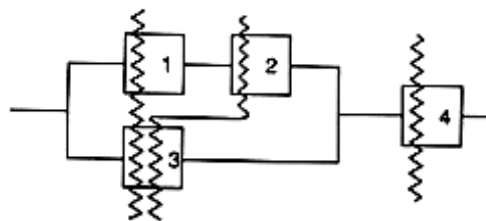

The minimal path sets are (1-2-4 3-4 ) shown below:

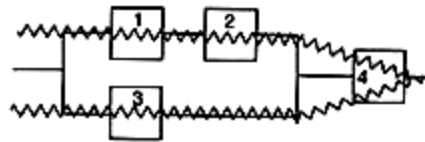

End of example▲

**Example 2-23**(Shooman,2002 page285)

What are the minimal cut and path sets between source  $a$  and target  $b$  given below?

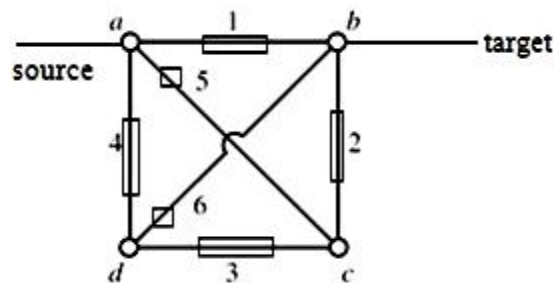

**Solution**

If all components fail but Component 1, the connection between  $a$  and  $b$  does not interrupt, then the set  $\{1\}$  is a tie set

If all components fail but Components 2 & 5, the connection between  $a$  and  $b$  does not interrupt, then the set  $\{2,5\}$  is a tie set

...

Functioning of the set with minimum elements 6,4 ensures the system operation, then Set  $\{6,4\}$  is a minimal path.

.....

The other cut and tie sets are determined with similar reasoning. The following table shows the minimal cut sets and minimal paths.

<b>The minimal cut sets and minimal paths of Example 2-23</b>			
Path no.	Components	Tie set no.	Components
1	5,4,1	1	1
2	2,6,1	2	2,5
3	3,6,5,1	3	6,4
4	4,3,2,1	4	2,3,4
5	6,3,5		

End of Example ▲

### **2-8-1 Calculation of reliability upper & lower bounds for complex systems using auxiliary networks**

To compute upper and lower reliability bounds for a complex system, based on the minimal cut sets and minimal paths, two auxiliary systems are constructed (Grosh, 1989, page 125).

1) Auxiliary network  $N_1$  is composed of parallel configuration of all the minimal path elements in series. This network is based on this fact that as far as one minimal path work the system works.

2) Auxiliary network  $N_2$  is composed of the series configuration of all the minimal cut elements in parallel (Grosh, 1989 p 127).

After calculating  $R_{N_1}$ , the reliability of Network  $N_1$  and that of network  $N_2$  ( $R_{N_2}$ ), we have the following inequality for  $R_{sys}$ , the reliability of the original system (based on Grosh, 1989 p 125 -6)

$$R_{N_2} < R_{sys} < R_{N_1} \quad (2-13)$$

For some reasons such as dependence of the subsystems of Network  $N_1$ , The calculated upper bound ( $R_{N_1}$ ) is usually over-estimated by this method. If  $R_{N_1}$  exceeds 1 set  $R_{N_1} = 1$

### Example 2-24

Draw the auxiliary networks for calculating the upper and lower bounds for RBD of Example 2-21.

#### Solution a) Auxiliary network $N_1$

Network  $N_1$  which is a parallel configuration of all the minimal path elements in series is shown below:

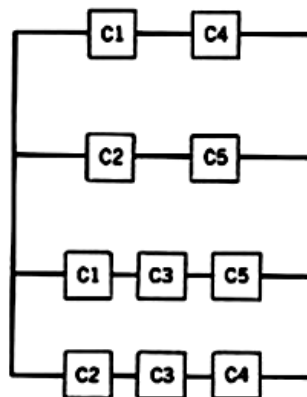

a) Network  $N_1$

The reliability of this RBD given by the following relationship is the upper bound for the original system reliability of Example 2-21:



$$R_{N1} = 1 - (1 - r_1 r_4)(1 - r_2 r_5)(1 - r_1 r_3 r_5)(1 - r_2 r_3 r_4)$$

**b) Auxiliary network N<sub>2</sub>**

Network N<sub>2</sub> which is the series configuration of all the minimal cut elements in parallel is shown below:

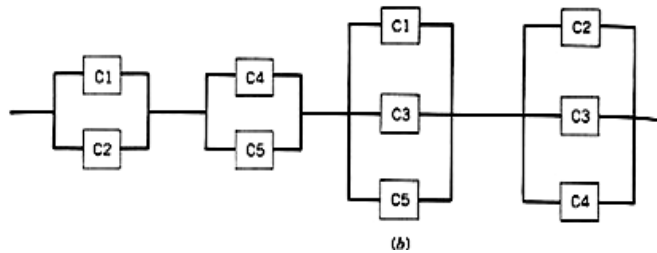

Network N<sub>2</sub>

The reliability of the above RBD given by the following relationship is the lower bound for the original system reliability:

$$R_{N2} = \left[ 1 - (1 - r_1)(1 - r_2) \right] \left[ 1 - (1 - r_4)(1 - r_5) \right] \left[ 1 - (1 - r_1)(1 - r_3)(1 - r_5) \right] \left[ 1 - (1 - r_2)(1 - r_3)(1 - r_4) \right]$$

Then  $R_{N2} < R_{sys} < R_{N1}$  ▲

**Example 2-25**

Draw the auxiliary networks for calculating the upper and lower bounds for the following RBD. The number in the box is the reliability of the component.

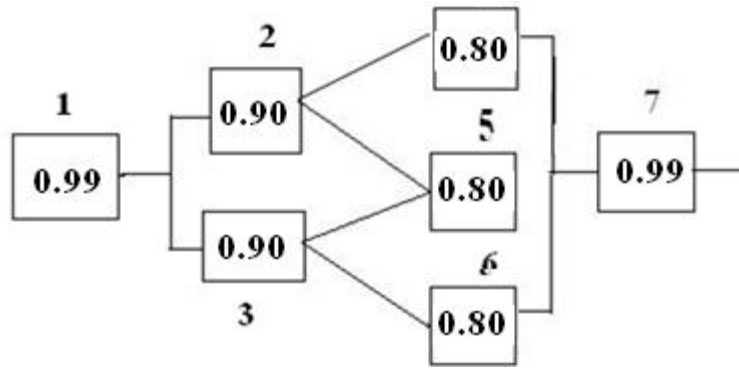

**Solution**

The minimal paths are:

- 1-3-6-7    1-3-5-7    1-2-4-7    1-2-5-7

The minimal cut set are:

- 1    7    2-3    4-5-6    2-5-6    3-4-5

The auxiliary networks  $N_1$  and  $N_2$  are shown below.

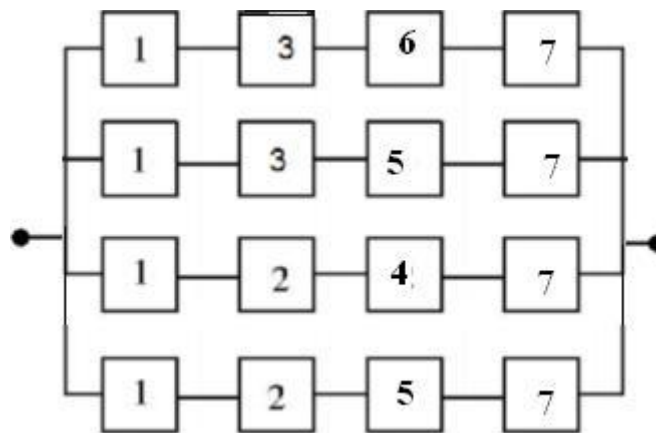

Network  $N_1$

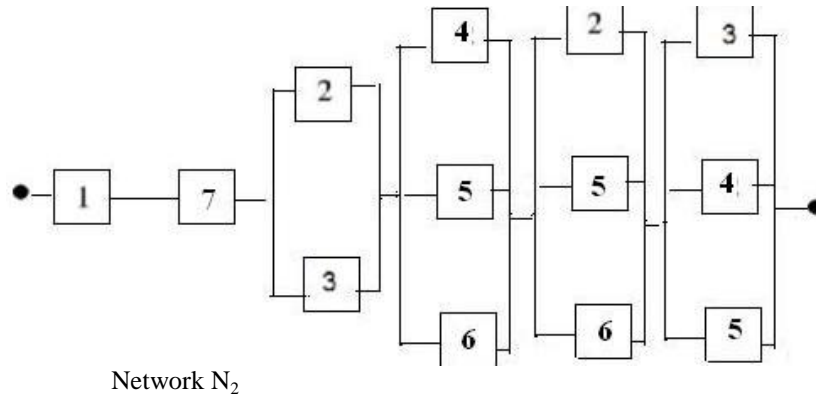

After calculating the reliability of Network  $N_1(R_{N_1})$  and that of Network  $N_2(R_{N_2})$  we could write  $R_{N_2} < R_{sys} < R_{N_1}$  ▲

### 2-8-2 An approximate formula for the upper and Lower reliability bounds of complex systems

Approximate bounds on system reliability from minimal cut sets and minimal path are given below (O'Connor & Kleyner 2012, p153)

$$1 - \sum_{j=1}^C \prod_{i \in A_j} (1 - R_i) < R_{sys} < \sum_{k=1}^T \prod_{i \in B_k} R_i \quad (2-14)$$

- $c$  The number of minimal cut sets
- $N$  The number of ct set
- $T$  The number minimal paths(tie sets)
- $A_j$  The components of  $j^{\text{th}}$  cut set,  $j = 1, 2, \dots, c$
- $B_K$  The components of  $k^{\text{th}}$  path,  $k = 1, 2, \dots, T$

$$1 - \sum_{j=1}^C \prod_{i \in A_j} (1 - R_i) =$$

1 - ( Product of unreliabilities of the components of  $A_1 + \dots +$  product of unreliabilities of the components of  $A_c$  )

$$\sum_{K=1}^T \prod_{i \in B_K} R_i =$$

Product of reliabilities of 1<sup>st</sup> path components + ... + Product of reliabilities of last path components

In the relationship 2-14, if the calculated upper bound is greater than 1, let the bound equal to 1; if the calculated lower bound is negative let the lower bound equal to zero.

### Example 2-26

Calculate the upper and lower bound for the reliability of the following system. Each component has the reliability of 90%.

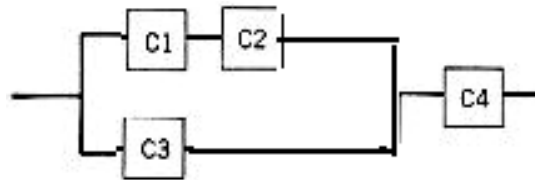

### Solution

The minimal cut sets and the minimal paths are given in the following table.

Path No. k	components	Cut Set No. j	components
k=1	1-2-4	j=1	1-3
k=2	3-4	j=2	2-3
		j=3	4

### Method 1: Using auxiliary networks

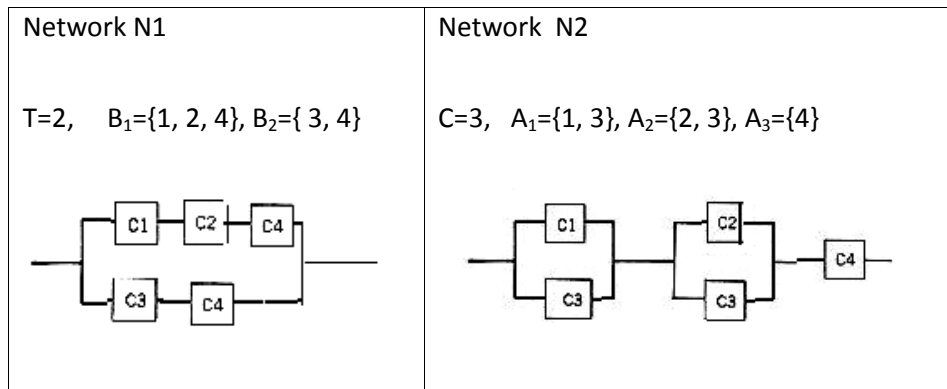

The reliability of the system ( $R_{sys}$ ) lies between:

$$R_{N1} = 1 - (1 - R_1 R_2 R_4)(1 - R_3 R_4) = 0.948$$

and

$$R_{N2} = [1 - (1 - R_1)(1 - R_3)][1 - (1 - R_2)(1 - R_3)](R_4) = 0.8821$$

Then  $0.8821 < R_{sys} < 0.948$ .

**Method 2: Using Relationship 2-14**

$$1 - \sum_{j=1}^C \prod_{i \in A_j} (1 - R_i) < R_{sys} < \sum_{k=1}^T \prod_{i \in B_k} R_i \Rightarrow$$

$$1 - [(1 - R_1)(1 - R_3) + (1 - R_2)(1 - R_3) + (1 - R_4)] < R_{sys} < R_1 R_2 R_4 + R_3 R_4$$

$$1 - [(1 - R_1)(1 - R_3) + (1 - R_2)(1 - R_3) + (1 - R_4)] = 0.88$$

$$R_1 R_2 R_4 + R_3 R_4 = 0.729 + 0.81 = 1.539 \rightarrow 1$$

Then  $0.88 < R_{sys} < 1$ .

It is obvious that this was an illustration for the methods. There was no need to apply these 2 methods to this simple RBD; because its exact value of reliability is simply calculated as follows:  $[1 - (1 - R_1 R_2)(1 - R_3)](R_4) = 0.8829$  ▲

**2-9 Applications of Bays reliability in Design**

According to Bays' theory, if the sample space of an experiment is  $SS = \{H_1 \cup \dots \cup H_k\}$  and  $H_i$ 's are mutually exclusive (i.e.  $H_i \cap H_j = \emptyset$  for  $i, j = 1, 2, \dots, k; i \neq j$ ), then:

$$\Pr(H_i | B) = \frac{\Pr(H_i) \Pr(B | H_i)}{\sum_{i=1}^k \Pr(H_i) \Pr(B | H_i)} \quad (2-15)$$

where B is an event defined on Sample space SS.

**Example 2-27**(K&L page 392)

Suppose a design engineer has developed a new mechanical system that has never been built or tested before. The engineer believes, based on his previous experience and intuition, that if the system has been designed properly to meet the performance criteria, the time to failure, is normally distributed with a mean of 50,000 kilometers. If the system is improperly designed, the mean life may be 30,000 kilometers. Based on his experience, the engineer has good confidence in his design. A priori, he says that the probability that the design has a mean life of 50,000 kilometers is 0.80, and hence 0.20 is the probability that the design has a mean life of 30,000 kilometers.

A single prototype is built and tested in a simulated environment that duplicates as nearly as possible the actual environment. The system is tested, but economic considerations dictate that (he testing be stopped at 40,000 kilometers. The engineer also says that, based on past experience, it is known that the standard deviation for the life of the system is 10% of the mean life.

The objective is to predict the reliability of the design .

**Solution**

Let

A = the event that the system has been tested and operated successfully for 40,000 kilometers.

$B_1$  = the event that the mean life is 50,000 kilometers,  $P(B_1) = 0.8$

$B_2$  = the event that the mean life is 30,000 kilometers,  $\Pr(B_2) = 0.2$

$$SS = B_1 \cup B_2$$

$$\Pr(B_i | A) = \frac{\Pr(B_i) \Pr(A | B_i)}{\Pr(B_1) \Pr(A | B_1) + \Pr(B_2) \Pr(A | B_2)} \quad i=1,2$$

$$\Pr(B_1) = 0.8$$

$$\begin{aligned} \Pr(A | B_1) &= \Pr(X > 40000, \mu = 50000) = \Pr \left[ Z > \frac{40000 - 50000}{(50000)(0.10)} \right] \\ &= \Pr(Z < -2) = 0.9772 \end{aligned}$$

$$\Pr(A | B_2) = \Pr \left( Z > \frac{40000 - 30000}{30000 \times 0.10} \right) = 0.00045 \Rightarrow$$

$$\Pr(B_1 | A) = \frac{\Pr(B_1) \Pr(A | B_1)}{\Pr(B_1) \Pr(A | B_1) + \Pr(B_2) \Pr(A | B_2)} = 0.9999$$

$$\Pr(B_2 | A) = 1 - \Pr(B_1 | A) = 1 - 0.9999$$

Suppose later, after production stage, one of these devices was selected for a mission of 35000-km- experiment. Assuming a normally distributed life time with mean 50000 km and  $\sigma = 5000$  km the reliability is given by

$$R = \Pr(X > 35000) = \Pr \left( Z > \frac{35000 - 50000}{5000} \right) = \Pr(Z > -3) = 0.99865$$

We are 99.99% confident about the mean used for this calculation because  $\Pr(B_1 | A) = 0.9999$ . Therefore we are 99.99% confident that the reliability of the device is 0.99865.

However before performing the test on the prototype which lead to a life of 40000 km we were able to state with 80% certainty (obtained from the engineers original beliefs) that the



35000-km reliability of the device is 0.99865. Because we were 80% confident about the mean used for the calculation. After the testing which was terminated after 40000 km, the probability of the event  $\mu=50000$  km conditioned on Event A was obtained 99.99%. Therefore the confidence for the predicted reliability shows increase using the Bays' theorem.

End of Example ▲

## Exercises<sup>1</sup>

1-(Problem 1 Page 68 K&L) Calculate the reliability of each of the following RBDs, where each component has the indicated reliability

---

<sup>1</sup> From K&L chapter 3

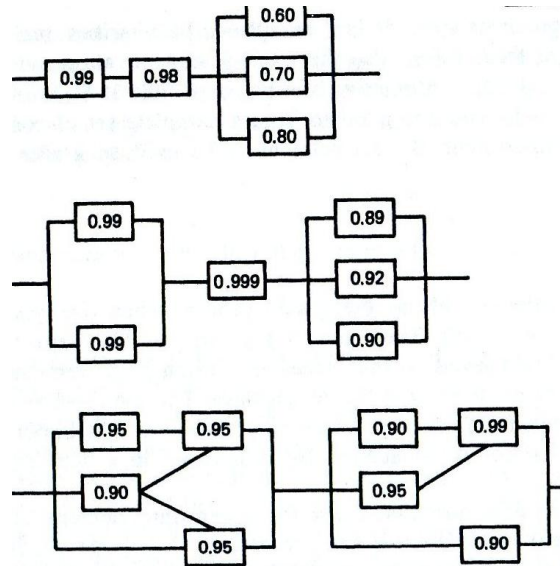

2. A system consists of 100 parts connected functionally in series. Each part has a 1000- hour reliability of 0.9999.

Calculate the reliability of the system.

3 A system is comprised of four major subsystems in parallel.

Each subsystem has a reliability of 0.900. At least two of the four subsystems must operate if the system is to perform properly. What is the reliability of this system?

4 A system is comprised of 10 subsystems connected functionally in series, [f a system reliability of 0.999 is desired, what is the minimum subsystem reliability that is needed?

5- -(Problem 5 Page 69 K&L) Assume that 4 wheel bolts are adequate from a design standpoint. However, the wheel attachment under consideration has 5 bolts. If the chances

of losing a wheel bolt are 0.00001, what is the reliability of this bolt system?

6- (Problemn 7 Page 70 K&L) The system diagram given below describes the circuitry for a neutral start switch on a manual automobile transmission. According to the service manual, in order to start this vehicle the clutch pedal must be fully depressed and the ignition switch must be in the start position.

- Define reliability as it relates to this system
- Draw an appropriate reliability block diagram(RBD)
- Assuming that each functional block in your RBD has a 0.0001 chance of failing, calculate the system reliability.

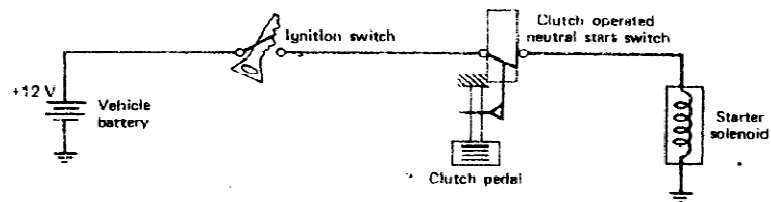

Figure 3.17 Neutral start switch circuit.

7- A manufacturer wishes to know the reliability of a skid protection system to be used on military tractor trailers. The system consists of:

- Two battery or generator powered sensors per wheel.
- One logic unit per sensor to predict wheel skid.
- A command unit, which operates an electric or an engine vacuum solenoid.

(d) The solenoids in (c) operate an actuator that controls the pressure to the brake.

. The system diagram (not reliability diagram) is shown below.

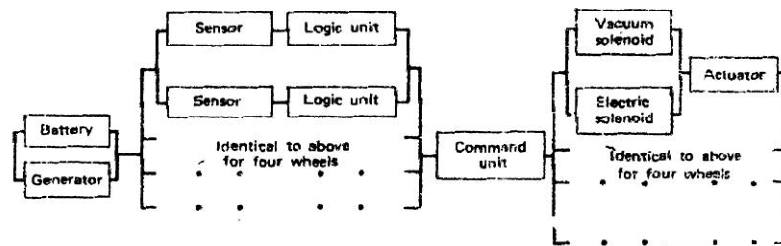

8) A DC battery has a time to failure that is normally distributed with a mean of 30 hours and a standard deviation of 30 hours,

(a) What is the 25-hour reliability?

(b) When should a battery be replaced to ensure, that there is no more than a 10% chance of failure prior to replacement?

(c) Two batteries are connected in parallel to power a light. Assuming, that the light does not fail, what is the 35- hour reliability for the power source?

(d) A particular battery has been in continuous use for 30 hours. What is the probability that this battery will last another 4 hours?

9) Calculate the reliability of the following two systems, where each component has the indicated reliability



(a)

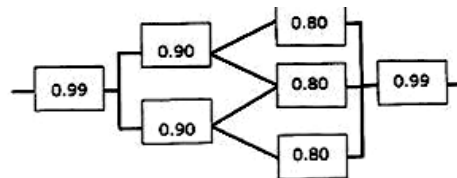

(b)

10) A customer of a bank uses 2 different cards for Automatic Teller Machines. One of them is connected to 2 accounts with reliabilities  $R_I$  and  $R_{II}$  and the other is connected to the account with reliability  $R_I$ . The reliability of the cards is  $R$ . Which card do you prefer?

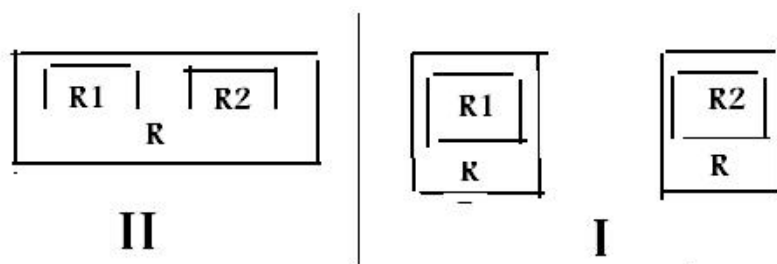

Ans.  $R_I > R_{II}$ .

11) To have a 6-component series system of at least 95% reliability, how many components do you suggest?

12) A system consists of several components with 94% reliability. To have a system with 95% reliability, what configuration do you suggest and many components?

14) In the following RBD, each component has the indicated reliability.  $B_2$  is a standby component which replaces  $B_1$  by a switch. The failure probability of the switch and the standby component when they are needed is negligible. Calculate the reliability the system with the given RBD and compare it with the case as if there is no redundant standby component.

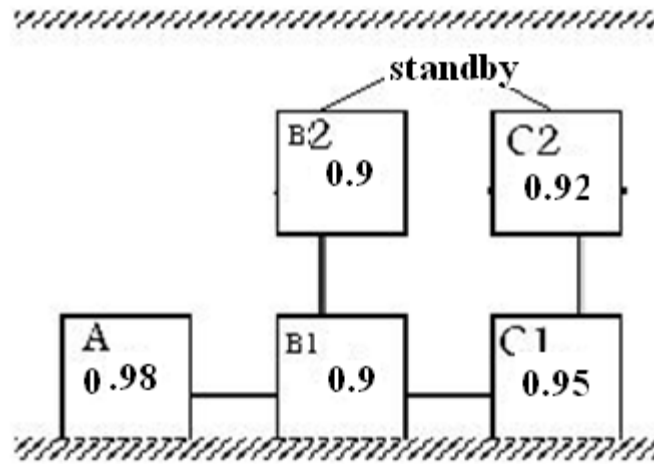

It is best to start every thing with  
trustfulness and  
end it with  
faithfulness

---

# Chapter 3

## Reliability

### Considerations

#### in Design

#### +UGF

### Technique

# 3

## Reliability Considerations in Design + UGF Technique

### Aims of the chapter

This chapter is divided into two sections. First section deals with reliability considerations in design. The second section introduces one of the methods used to conduct reliability analysis; i.e. the universal generating function(UGF) method which is a method of modern discrete mathematics.

### 3.1 Reliability Considerations in Design

The design process dictates the system configuration and the configuration chosen influences the reliability level as well as the cost of achieving this level. Thus, a preliminary reliability analysis as well as the many other design factors should be considered during the design phase. .(K&L page 62)

Since the designer is the system architect he or she should be familiar with the basic reliability analysis concepts that can be used to evaluate the design. Only after the design is completed can an independent reliability group analyse and test the product. So it is important that the designer evaluate the reliability levels and costs of various designs before the final choice is made.(K&L page 63)

A frequently used measure of complexity is the number of components in a system. It is a fundamental tenet of reliability



engineering that as the complexity of a system increases, the reliability will decrease, unless compensatory measures are taken (Lewis, 1994 page).

This section will emphasize some trade-offs between reliability and the number of components. This might be helpful to a designer in developing alternatives (K&L page 63).

### 3.1-1 Reliability considerations in series configurations

Consider the series system shown in Fig 3.1

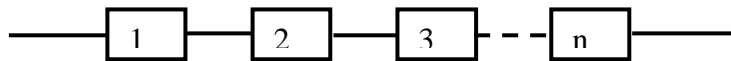

Fig 3-1 A series configuration

If the reliability of each component is equal to  $R$  i.e.

$R_1 = R_2 = \dots = R_n = R$  then according to Eq.2-1 the system reliability ( $R_{sys}$ ) is given by  $R_{sys} = R^n$ .

$R_{sys}$  depends on  $R$  and  $n$  (reliability and number of components). This relationship is shown in Fig 3.2.

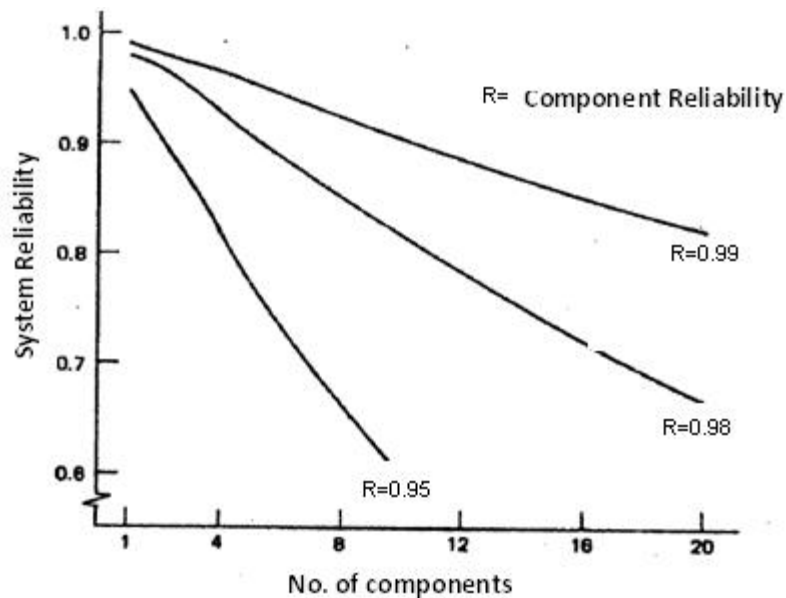

Fig 3.2 The relationship between An n-component system's reliability, and the number components for 3 values of R

Some considerations on the design of a series configuration follows. According to Fig 3.2:

- 1) For a given component reliability (R), the reliability of a series system can be improved by decreasing the number of components in series. Conversely the system reliability is decreased as the number of components increases.
- 2) For a given number of components, the reliability of a series system will improve if components of greater reliability are used.
- 3) When the number of components is increased, the system reliability will not change if components of appropriate greater reliability are used.

The following figure also conveys some concepts similar to those that does Fig. 3.2.

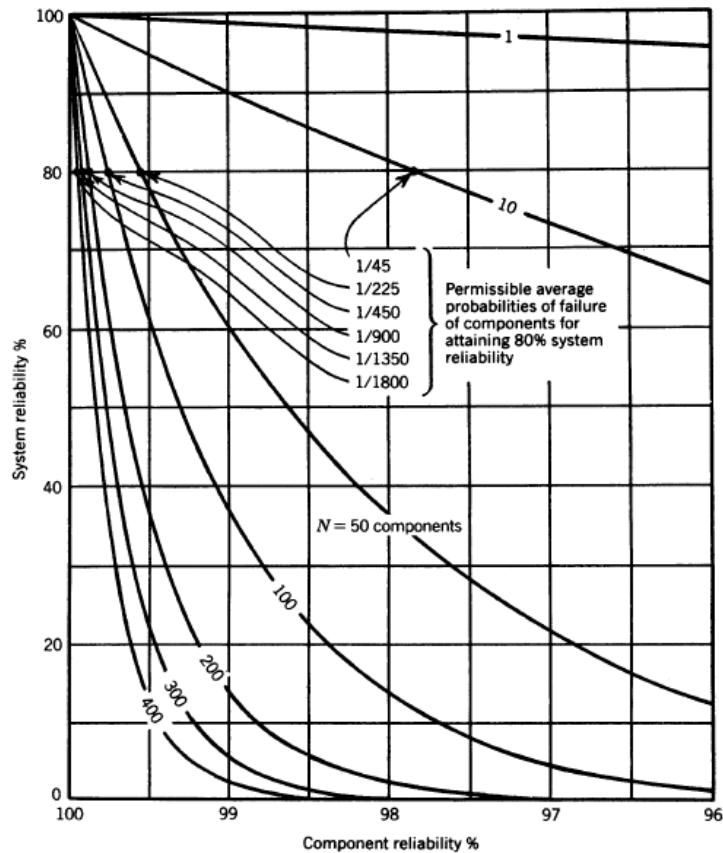

Fig.3.3 Series system reliability as a function of number and reliability of components (Lewis,1994 page 253)

### 3.1-2 Reliability considerations in parallel configurations

The paralleling of components is usually mentioned as a means to improve system reliability. However the gains are not always realizable(K&L page 64). Consider the RBD of m-

component system in which all components are actively parallel. If the reliability of components are the same and equal to R, the reliability of the system shown in Fig. 3-4 is:

$R_{\text{sys}} = 1 - (1 - R)^m$ . Figures 3.5 and 3.6 plot this relationship.

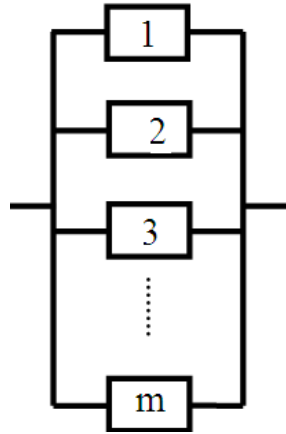

Fig 3-4 A Parallel-active system

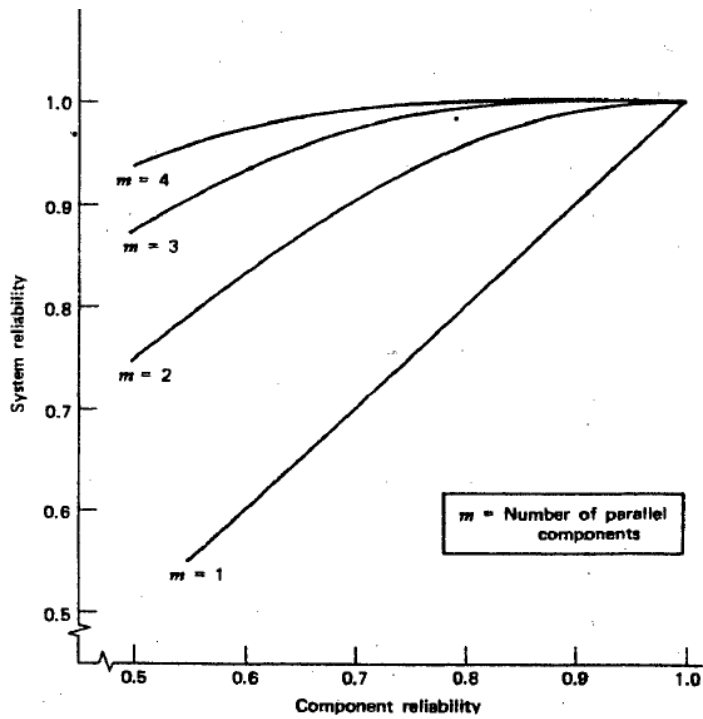

Fig. 3.5 Parallel system reliability as a function of reliability of components for 4 values of  $m$  (K&L page 64)

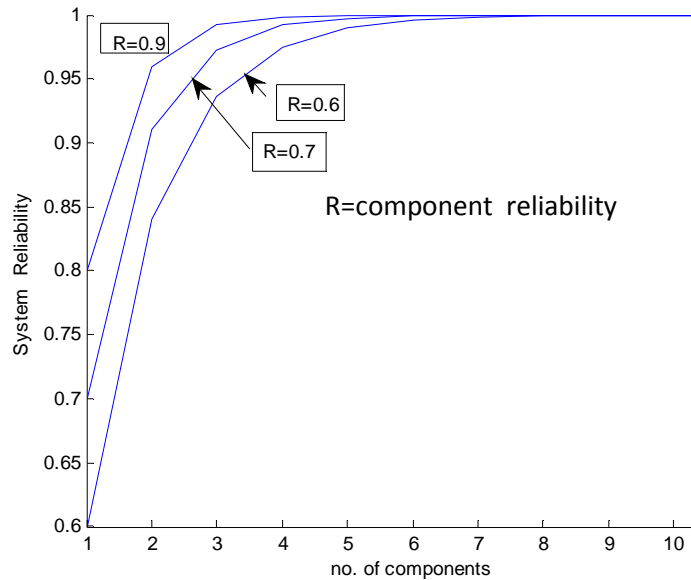

Fig. 3.6 Parallel-active system reliability as function of no. of components for 3 values of R.

Some considerations regarding this system follows:

- 1- For a given component reliability the more the number of components (m) the more the system reliability; however for  $m > 4$  the increase slows down (see Fig. 3.5 and 3.6 )
- 2- To use cheaper and less reliable components and at the same time to keep the system reliability fixed, the number of component has to be increased, as it is evident from Fig. 6.3.
- 3- For a given number of components, the more the component reliability (R) the more the system reliability.

For example if  $m = 2$  Fig. 3-6 gives the system reliability 0.84 for  $R = 0.6$  and 0.91 for  $R = 0.7$ .

It is worth knowing that

designing a parallel system for a mechanical device is usually extremely difficult. Some forms of parallel arrangement such as providing spare parts (a standby parallel arrangement) or using a load-sharing design (a shared parallel arrangement) are probably more representative of the true situation.(K&L).

### **3.1-3 Reliability considerations in series-parallel configurations**

Remember that given an  $n$ -component series system, we can either provide redundant components, which give a system design diagram as shown in Fig.3.7, or provide a total redundant system as shown in Fig.3.9.

As you know the former redundancy is known as low-level redundancy whereas the latter(system level redundancy) is also called high-level redundancy.

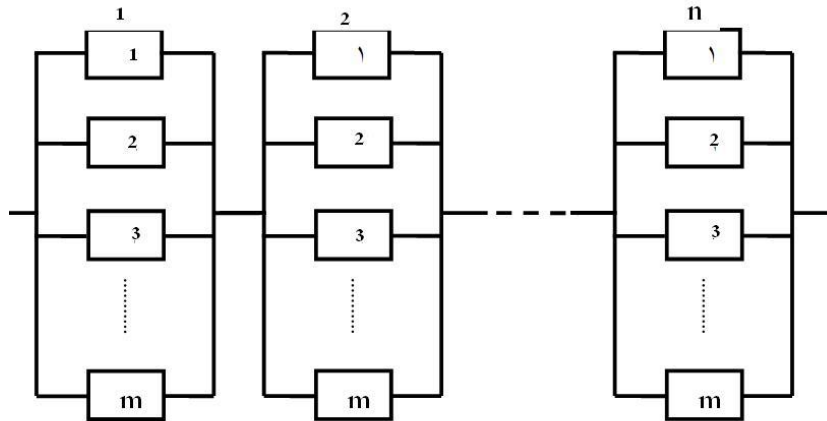

Fig. 3-7 Component redundancy or low-level (LL) redundancy

Now we would like to make some comparisons between LL and HL redundancies. Assume all components are independent of each other and have the same reliability of  $R$ .

### Reliability of LL redundancy

The reliability of LL configuration in Fig 3.7 is given by:

$$(R_{sys})_{LL} = [1 - (1 - R)^m]^n \quad (3-1)$$

This equation is plotted in Fig 3.8

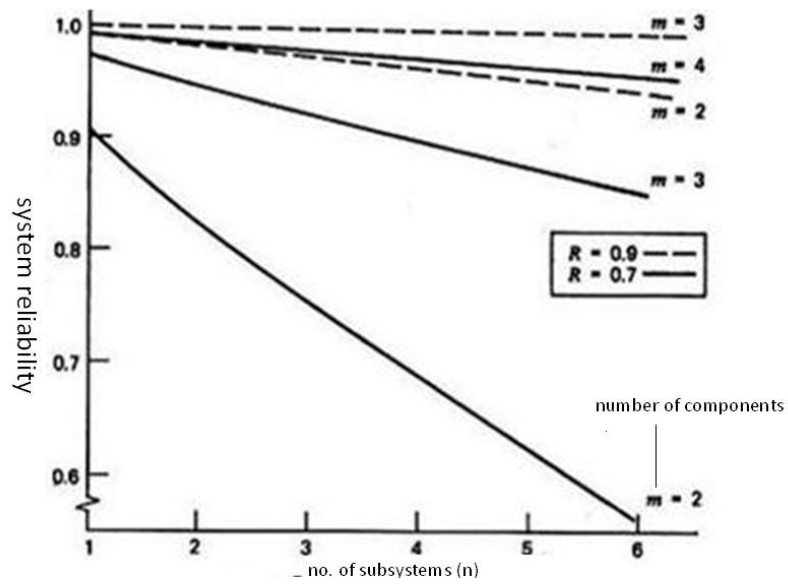

Fig. 3.8 LL configuration's reliability in terms of no. of subsystems (n) and number of components(K&L p66)

### Reliability of HL redundancy

The reliability of HL configuration in Fig 3.9 is:

$$(R_{sys})_{HL} = 1 - [1 - R^n]^m \quad (3-2)$$

where

m is the number of subsystem and

n is the number of components in each subsystem



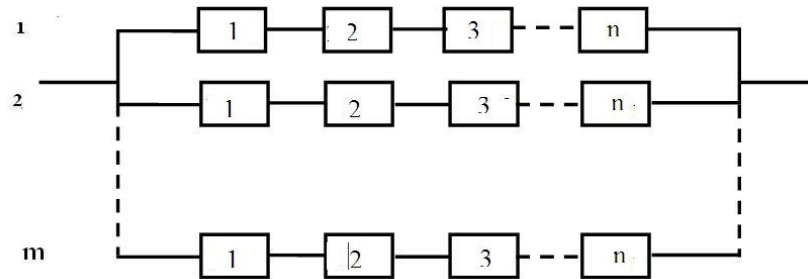

Fig. 3.9 High-level or system redundancy

Eq. 2-3 is plotted in Fig. 3.10 in terms of  $n$  for 3 values of  $m$  and 2 values of  $R$ .

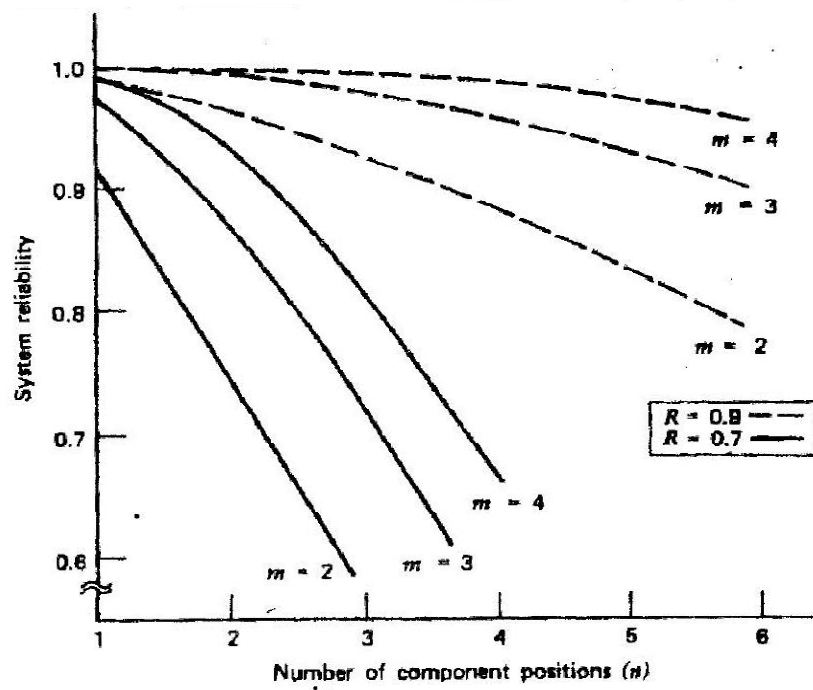

Fig. 3.10 HL configuration's reliability in terms of no. of components of subsystems ( $n$ ) (K&L p67)

Now we would like to compare HL and LL redundancies.

By comparing the graphs in Figs. 3.8 and 3.10 it is evident that the low-level redundancy gives a higher system reliability in all cases. However, the difference is not as pronounced if components have high reliabilities. Basically the 2 Figures indicate that providing spare components will result in better overall reliability than providing a spare system. Of course, this can be applied at different levels to subsystems, depending on the possible system breakdown, for, in some instances, design or system peculiarities make it impossible to apply all of these rules. Also the total system operation must be considered. For instance, if your automotive brake system fails at 80 km/h in heavy traffic it would not do you any good to have a complete set of components in your glove compartment. So the rules must be used as guides and applied with discretion( K&L page67-68).

**Example 3.1** Find the reliability of the LL redundancy given in Fig. 3.7 and that of the HL redundancy given in Fig 3-9 for

a)  $n = 3$   $m = 4$ ,  $R = 0.7$

b)  $n = 3$   $m = 2$ ,  $R = 0.9$

**Solution**

**a)**

From Eq. 3.1

$$(R_{sys})_{LL} = [1 - (1 - R)^m]^n, n = 3 \quad m = 4, R = 0.7$$

$$(R_{sys})_{LL} = 0.9759$$

From Eq. 3.2

$$(R_{sys})_{HL} = 1 - [1 - R^n]^m, n = 3 \quad m = 4, R = 0.7$$

$$(R_{sys})_{HL} = 0.81368$$

**b)** for  $n = 3$   $m = 2$ ,  $R = 0.9$  From Eqs. 3.1 and 3.2  $\Rightarrow$

$$(R_{sys})_{HL} = 0.93 \qquad (R_{sys})_{LL} = 0.97$$

End of example ▲

### 3-2 Universal Generating Function(UGF) analysis of Reliability Systems

Before dealing with Universal Generating Function.; It is worth reminding that in the reliability analysis of system 2 different systems are identified: binary -state system and multi-state system (MSS).

a binary -state system assumes only two possible states for a system and its components: either perfect functional or completely down

and multi-state systems reliability models allow both the system and its components to assume more than two levels i.e. different performance levels and several failure modes with various effects on the entire system performance . In other words, in multi-state systems the system and its components have multiple possible states: some intermediate states as well as complete failure and perfect functioning.

Different methods, such as Monte Carlo simulations, extension Boolean models, stochastic processes and the universal generating function (UGF) method have been proposed to conduct the reliability analysis of MSSs<sup>1</sup>.

Although the UGF method which is a method of modern discrete mathematics has a high computing speed in the reliability assessment of multi-state systems (MSSs), it can be

---

<sup>1</sup> Jinhua, Mi, et al, 2015  
Belief Universal Generating Function Analysis of Multi-State Systems Under Epistemic Uncertainty and Common Cause Failures IEEE Transactions on Reliability Vol. 64 No.4

used for the analysis of binary-state systems. we proceed now with the use of UGF in the latter case.

Universal generating function(UGF) is an extension of moment generating function(MGF) and probability generating function(PGF). UGF could be used in determining the probabilistic distribution of complicated functions of some discrete random variables. Before proceeding with UGF, some definitions are reminded.

### 3.2-1 Moment generating function of discrete random variables

Consider a discrete random variable(rv)  $X$  which can take values  $x_0, \dots, x_k$  such that  $\Pr(X = x_i) = p_i$  and  $\sum_{i=0}^k p_i = 1$ . the mapping  $x_i \rightarrow p_i$  is usually called probability mass function. The mean of  $X$  and MGF of this rv is:

$$E(X) = \sum_{i=0}^k x_i p_i$$

$$MGF_X(t) \text{ or } \varphi_X(t) = E(e^{tX}) = \sum_{i=0}^k p_i e^{t x_i}$$

For example if  $X$  has a binomial distribution  $B(k, \pi)$ , then  $\varphi_X(t) = (\pi e^t + 1 - \pi)^k$ .

**Some properties** of moments generating functions (MGFs) are as follows:

1. The MGF of a random variable(rv) is unique i.e. if the MGF exists for an rv, then there one and only one distribution associated with that MGF uniquely defines the distribution of the rv.
2. The MGF of the sum of some independent rv's is equal to the product of the MGFs of the rv's:

$$\varphi_{\sum_{i=1}^k X_i}(t) = \prod_{i=1}^k \varphi_{X_i}(t).$$

$$3. E(X^k) = \frac{d^{(k)}}{dt^k} \varphi_X(t)|_{t=0}$$

i.e. the  $k^{\text{th}}$  derivative of  $\varphi_X(t)$  with respect to  $t$  gives the value of  $k^{\text{th}}$  moment of the distribution about the origin, for  $t=0$ .

4. The additive property of some distributions such as Poisson and normal distributions could be verified by MGF.

### 3.2-2 Z-transform or probability generating function of discrete random variables

The probability generating function of a discrete random variable is defined as follows:

$$\omega(z) = E(z^X) = \sum_{i=0}^k p_i z^{X_i} \quad (3-3)$$

This function is also called Z-transform if variable X.

#### Example 3.2

If a variable X takes on the values  $x_1 = 1$ ,  $x_2 = 2$  and  $x_3 = 5$  with probabilities 0.3, 0.5 and 0.10. Find the Z-transform of the variable.

#### Solution

$$\omega_X(z) = \sum_{i=1}^3 p_i z^{x_i} = 0.3 \times z^1 + 0.6 \times z^2 + 0.1 \times z^5$$

End of Example ▲

### Some properties of z-transform

A useful property of z-transform is its ability to solve difference equations. Some other common properties are:

1. The probability function of a random variable whose z-transform is  $\omega(z)$  is derived from the following relationship:

$$p_j = \frac{1}{j!} \times \frac{d^{(j)}}{dz^j} \omega(z)|_{z=0} \quad (3-4)$$

2. The first derivative of  $\omega(z)$  with respect to  $z$  gives the value of the distribution mean, for  $z=0$ .

$$\omega'(z) = \frac{d}{dz} E(z^X) = \frac{d}{dz} \sum (z^{x_i} p_i) = \sum_{i=0}^k x_i z^{x_i-1} p_i \quad (3-5)$$

$$z = 1 \implies \omega'(z) = \sum x_i p_i = E(X)$$

3. The  $z$ -transform of the sum of some independent rv's is equal to the product of the  $z$ -transforms of the rv's:

$$\omega_{\sum_{i=1}^k x_i}(z) = \prod_{i=1}^k \omega_{x_i}(z) \quad (3-6)$$

4. If in the definition of the MGF  $e^t$  is replaced by  $z$ , then one gets  $z$ -transform of the random variable.

### Example 3.3

Suppose  $k$  independent trials each having 2 outcomes: success with probability  $\pi$  and failure with probability  $1 - \pi$ . are performed independently. For  $j^{\text{th}}$  trial let  $X_j$  defined below:

$$\begin{cases} p(x_j = 1) = \pi \\ p(x_j = 0) = 1 - \pi \end{cases} \quad \hookrightarrow \quad p_{x_j}(x) = \begin{cases} \pi & x_j = 1 \\ 1 - \pi & x_j = 0 \end{cases}$$

Therefore the  $z$ -transform of  $X_j$  is:  $\omega_{X_j}(Z) = \pi z^1 + (1 - \pi) z^0$

If  $X = \sum_{j=1}^k X_j$  then  $X$  represents the number of successes that

occurs in the  $k$  independent trials and the  $z$ -transform of  $X$  is:

$$\omega_X(z) = [\pi z + (1 - \pi)] \times \dots \times [\pi z + (1 - \pi)] = [\pi z + (1 - \pi)]^k$$

This  $z$ -transform is that of a binomial random variable with parameters  $(k, \pi)$  whose probability function is given by:

$$p_i = \binom{k}{i} \pi^i (1 - \pi)^{k-i} \quad 0 \leq i \leq k$$

End of Example ▲

### 3-2-3 The Universal Generating Function(UGF)

Consider independent random variables  $X_1, \dots, X_i, \dots, X_n$  with mapping  $x, p$ . If we want to find the probability function of  $f(X_1 \dots X_n)$ , we have to obtain a vector  $Y$  composing all possible values of  $f$  and the probability of the occurrence of the values.

Each possible value of  $f$  corresponds to a combination of the values of its arguments  $X_1, \dots, X_n$ . Let the probability function of  $X_i$  taking  $k_i$  values be represented by:

$$x = x_{i1}, \dots, x_{ik_i} \quad p = p_{i1}, \dots, p_{ik_i}$$

Then the total number of possible combinations constituting the range of  $f(X_1 \dots X_n)$  is  $= \prod_{i=1}^k (k_i)$ , where  $k_i$  is the number of possible values that  $X_i$  takes.

Since  $X_1 \dots X_n$  are independent the probability of the  $j^{\text{th}}$  combination of the realization of  $f$  variates is equal to:

$$\text{probability of } j^{\text{th}} \text{ variate of } f=q_j = \prod_{i=1}^n p_{ij_i}$$

where(Levitin,2010page)

$p_{ij_i}$  is the probability of the realization of the arguments composing the combination.

And the corresponding value of  $f$  can be obtained as:

$$f_j = f(X_{1j_1}, \dots, X_{nj_n}).$$

Some combinations might have the same values. Since all combinations are mutually exclusive, therefore the probability

that the function  $f$  takes on some value is equal to the sum of the combination producing this value(Levitin,2010 page 6). Let  $A_h$  be a set of combinations producing the value  $f_h$ . If the total number of different realization of the function  $f(X_1 \dots X_n)$  is  $H$ , then the probability function of  $f$  is:

$$Y = \{f_h : 1 \leq h \leq H\},$$

$$q = \left\{ \sum_{(x_{1j_1}, \dots, x_{1j_n}) \in A_h} \prod_{i=1}^n p_{ij_i} : 1 \leq h \leq H \right\} \quad (3 - 7)$$

**Example 3-4**

Consider independent random variables  $X_1, X_2$  with the following probability functions:

$$P_{X_1}(x) = \begin{cases} 0.6 & x = 1 \\ 0.4 & x = 4 \end{cases} \quad P_{X_2}(x) = \begin{cases} 0.1 & x = 0.5 \\ 0.6 & x = 1 \\ 0.3 & x = 2 \end{cases}$$

Find the probability function of  $Y = f(X_1, X_2) = X_1^{X_2}$ .

**Solution**

All possible combinations of  $X_1, X_2$  and the probability function of  $Y$  is given in the following table:

	$X_1$	$X_2$	$Y = X_1^{X_2}$	$P_Y(y)$
1	1	0.5	1	$0.6 \times 0.1 = 0.06$
2	4	0.5	2	$0.4 \times 0.1 = 0.04$
3	1	1	1	$0.6 \times 0.6 = 0.36$
4	4	1	4	$0.4 \times 0.6 = 0.24$
5	1	2	1	$0.6 \times 0.3 = 0.18$
6	4	2	16	$0.4 \times 0.3 = 0.12$

As the table shows some combinations have the same value . Since all combinations are mutually independent then the



probability of the occurrence of this same value is the some of the probabilities of the combinations producing the value. e.g.:

$$P(Y = 1) = \Pr(X_1 = 1, X_2 = 0.5) + \Pr(X_1 = 1, X_2 = 1) + \Pr(X_1 = 1, X_2 = 2) \Rightarrow P(Y = 1) = 0.06 + 0.36 + 0.18 = 0.6$$

Therefore according to the calculations in the table;

$$Y = \{y_1 = 1, y_2 = 2, y_3 = 4, y_4 = 16\},$$

$$q = (0.6, 0.04, 0.24, 0.12). \text{End of Example } \blacktriangle$$

For solving problems such as the one given in Example 3-4, another approach called the UGF technique could be used. The technique, based on using z-transform and a composition operator (denoted by  $\otimes_f$ ), is described below.

Let  $X_i$  takes on  $x_{i1}, \dots, x_{ik_i}$  with probabilities  $p_{i1}, \dots, p_{ik_i}$ , the corresponding z-transform is the following polynomial:

$$\omega_{X_i}(Z) = \sum_{j=1}^{k_i} p_{ij} Z^{x_{ij}} \quad (3-8)$$

As you know the z-transform of the sum of independent random variables  $X_1, \dots, X_n$  is the product of their z-transforms:

The probability function of a combination of several independent random variable such as  $Y$  given in Example 3-4 could be obtained from its z-transform. Therefore if one could find the z-transform of a combination, it will be easy to obtain the probability function of the combination.

### UGF Technique

In the so-called UGF technique, To calculate the z-transform,  $U(z)$ , of every arbitrary combination(function) of independent random variables  $X_1, \dots, X_n$ , replace the product operator ( $\prod$ ) on the z-transforms in Eq. 3-6 with an appropriate operator denoted by  $\otimes_f$ . Here the z-transform of random variable  $X_i$  of independent variables  $X_1, \dots, X_i, \dots, X_n$  is denoted by  $U_i(z)$ . The z- transform of  $f(X_1, \dots, X_n)$  is denoted by  $U_f(z)$  or  $U(z)$  (Livitin, 2010page 8). According to this notation for 2 variables:

$$U(z) = \otimes_f [U_1(z), U_2(z)] = [U_1(z) \otimes_f U_2(z)] \quad (3 - 9)$$

for n variables(Livitin, 2010page 8):

$$U(z) \text{ or } U_f(z) = \otimes_f (U_1(z), \dots, U_n(z)) \quad (3 - 10)$$

$$U_f(z) = \otimes_f \left( \sum_{j_1=1}^{k_1} P_{1j_1} z^{X_{1j_1}} \right) = \sum_{j_1=1}^{k_1} \sum_{j_2=1}^{k_2} \dots \sum_{j_n=1}^{k_n} \left( \prod_{i=1}^n P_{ij_i} \times z^{f(x_{i j_1}, \dots, x_{n j_n})} \right) \quad (3 - 11)$$

The technique based on using z-transform and composition operators  $\otimes_f$  is named universal z-transform or universal (moment) generating function (UGF) technique (Livitin, 2010 page 8 ). UGF technique has applications such as finding the probability function of an arbitrary function of several independent random variables and finding the reliability of complicated systems. For other applications refer to reverences such as chapter 2& 3 in Levitin(2010).

Notice that(Livitin,2010 page 8):

1-Although  $U_j(z)$  resembles a polynomial,  $U(z)$  is not necessarily a polynomial.

2-When the  $U(z)$  represents the probability function of a random function  $f(X_1, \dots, X_n)$ , the expected value of this function can be obtained as the first derivative of  $U(z)$  at  $z=1$ .

**Example 3-5**(Levitin, 2010, page9)

Consider the probability function of Y from the table in Example 3-4. The z-transform of Y takes the form:

$$U(z) = 0.06Z^1 + 0.04Z^2 + 0.36Z^1 + 0.24Z^4 + 0.18Z^1 + 0.12Z^{16}$$

Merging the like forms results in:

$$U(z) = 0.6Z^1 + 0.04Z^2 + 0.24Z^4 + 0.12Z^{16}$$

As you may have noticed, this function represents the probability function for Y as follows:

$$Y = (1, 2, 4, 16), \quad q = (0.6, 0.04, 0.24, 0.12)$$

which is the same as what was obtained in Example3-4. ▲

The described technique of determining the probability functions is based on an enumerative approach, which is extremely time consuming. Fortunately, many functions used in reliability engineering produce the same values for different combinations of the values of their arguments ( $X_j$ 's). The combination of recursive determination of the functions with simplification techniques based on the like terms collection

allows one to reduce considerably the computations needed to obtain the probability function of complicated functions.

The following procedure is easier for solving this example. Based on the data in Example 3-4 the u-function of  $X_1$  and  $X_2$  is as follows:

$$U_1(z) = 0.6z^1 + 0.4z^4, \quad U_2(z) = 0.1z^{0.5} + 0.6z^1 + 0.3z^2$$

Let u-function of  $Y = X_1^{X_2}$  be denoted by  $U_Y(z)$ , then according to Eq. 3.9

$$U_Y(z) = U_1(z) \otimes_{power} U_2(z) \Rightarrow$$

$$U_Y(z) = (0.6z^1 + 0.4z^4) \otimes_{power} (0.1z^{0.5} + 0.6z^1 + 0.3z^2)$$

$$U_Y(z) = 0.6 \times 0.1 Z^{(1^{0.5})} + 0.6 \times 0.6 Z^{(1^1)} + 0.6 \times 0.3 Z^{(1^2)} + \\ 0.4 \times 0.1 Z^{(4^{0.5})} + 0.4 \times 0.6 Z^{(4^1)} + 0.4 \times 0.3 Z^{(4^2)} \Rightarrow$$

$$U_Y(z) = 0.6Z^1 + 0.04Z^2 + 0.24Z^4 + 0.12Z^{16}$$

From this function the probability function of Y is obtained:

$$Y = (1, 2, 4, 16)$$

$$\text{probabilities} = q = (0.6, 0.04, 0.24, 0.12)$$

End of example ▲

**Example 3-6**( based on Livitin, 2010 page 9)

Random variables  $X_1, \dots, X_5$  are independent and the data for their probability functions are given in the following table:

$X_1$		$X_2$		$X_3$		$X_4$		$X_5$	
$(x)$	$(p)$	$x$	$p$	$x$	$p$	$x$	$p$	$x$	$p$
$x_{1,0}=8$	$p_{1,0}=0.7$	5	0.6		0.1	0	0.6	1	0.5
$x_{1,1}=10$	$p_{1,1}=0.3$	8	0.3		0.5	2	0.4	1.5	0.5
		12	0.1		0.4				

Find the probability function of

$$Y = f(x_1 \dots x_5) = [\max(X_1, X_2) + \min(X_3, X_4)](X_5).$$

### Solution

The total number of term multiplication procedures that one has to perform using enumerative approach is

$2 \times 3 \times 3 \times 2 \times 2 = 72$ ; however applying UGF technique as performed below reduces this amount to only 26 (Livitin,2010 page11).

The u-function of the variables are:

$$U_1(z) = p_{1,0}Z^{x_{1,0}} + p_{1,1}Z^{x_{1,1}} = 0.7Z^8 + 0.3Z^{10}$$

$$U_2(z) = p_{2,0}Z^{x_{2,0}} + p_{2,1}Z^{x_{2,1}} + p_{2,2}Z^{x_{2,2}} = 0.6Z^5 + 0.3Z^8 + 0.1Z^{12}$$

$$U_3(z) = p_{3,0}Z^{x_{3,0}} + p_{3,1}Z^{x_{3,1}} + p_{3,2}Z^{x_{3,2}} = 0.1Z^0 + 0.5Z^3 + 0.4Z^5$$

$$U_4(z) = p_{4,0}Z^{x_{4,0}} + p_{4,1}Z^{x_{4,1}} = 0.6Z^0 + 0.4Z^2$$

$$U_5(z) = p_{5,0}Z^{x_{5,0}} + p_{5,1}Z^{x_{5,1}} = 0.5Z^1 + 0.5Z^{1.5}.$$

Let us introduce the following 3 auxiliary random variables:

$$X_6 = \max(X_1, X_2) \quad X_7 = \min(X_3, X_4) \quad X_8 = X_6 + X_7$$

Therefore  $Y = X_8X_5$ . Using composition operators on pairs of u-functions, the probability function of Y is obtained as follows:

$$\begin{aligned} U_6(z) &= U_1(z) \otimes_{\max} U_2(z) = \\ &= (0.7Z^8 + 0.3Z^{10}) \otimes_{\max} (0.6Z^5 + 0.3Z^8 + 0.1Z^{12}) = \end{aligned}$$

$$\begin{aligned} & \underbrace{0.42}_{0.7 \times 0.6} Z^{\max(8,5)} + \underbrace{0.21}_{0.7 \times 0.3} Z^{\max(8,8)} + \\ & \underbrace{0.07}_{0.7 \times 0.1} Z^{\max(8,12)} + \underbrace{0.18}_{0.3 \times 0.6} Z^{\max(10,5)} \\ & + 0.09 Z^{\max(10,8)} + 0.03 Z^{\max(10,12)} \Rightarrow \\ U_6(z) &= 0.63Z^8 + 0.27Z^{10} + 0.1Z^{12} \end{aligned}$$

$$\begin{aligned} U_7(z) &= U_3(z) \otimes_{\min} U_4(z) \\ &= (0.1Z^0 + 0.5Z^3 + 0.4Z^5) \otimes_{\min} (0.6Z^0 + 0.4Z^2) = \end{aligned}$$

$$\begin{aligned} & 0.06Z^{\min(0,0)} + 0.04Z^{\min(0,2)} + 0.3Z^{\min(3,0)} + 0.2Z^{\min(3,2)} \\ & + 0.24Z^{\min(5,0)} + 0.16Z^{\min(5,2)} \Rightarrow \\ U_7(z) &= 0.64Z^0 + 0.36Z^2 \end{aligned}$$

$$U_8(z) = U_6(z) \otimes_+ U_7(z) =$$

$$= (0.63Z^8 + 0.27Z^{10} + 0.1Z^{12}) \otimes_+ (0.64Z^0 + 0.36Z^2) =$$

$$= 0.4032Z^{8+0} + 0.2268Z^{8+2} + 0.1728Z^{10+0} + 0.0972Z^{10+2} + 0.064Z^{12+0} + 0.036Z^{12+2} =$$

$$U_8(z) = 0.4032Z^8 + 0.3996Z^{10} + 0.01612Z^{12} + 0.036Z^{14}$$

$$\begin{aligned} U_Y(z) &= U_8(z) \otimes_{\times} U_5(z) \\ &= (0.4032Z^8 + 0.3996Z^{10} + 0.01612Z^{12} \\ & \quad + 0.036Z^{14}) \otimes_{\times} (0.5Z^1 + 0.5Z^{1.5}) \end{aligned}$$

After necessary calculations and simplification, the final answer for  $U_Y(z)$  is:

$$\begin{aligned} U_Y(z) &= 0.2016Z^8 + 0.1998Z^{10} + 0.2822Z^{12} + 0.018Z^{14} \\ & \quad + 0.1998Z^{15} + 0.0806Z^{18} + 0.018Z^{21} \end{aligned}$$

From  $U_Y(z)$  the probability function of Y is obtained as follows:

$$\begin{aligned} Y &= (8, \quad 10, \quad 12, \quad 14, \quad 15, \quad 18, \quad 21) \\ q &= (0.02016, 0.1998, 0.2822, 0.018, 0.1998, 0.0806, 0.018) \end{aligned}$$

End of Example ▲

### 3-2-4 derivation of the reliability using UGF

Given the UGF of a system, its reliability could be estimated> This is illustrated in the following Example.

### Example 3-7

The universal generating function of a system is:

$$U(z) = 0.1Z^8 + 0.15Z^{20} + 0.4Z^{40} + 0.35Z^{50},$$

Find 20-hour reliability of the system.

#### Solution

$$R_{20} = Pr(X > 20) = 0.40 + 0.35 = 0.75.$$

End of Example ▲

### 3-2-4 Reliability Analysis of Binary -State Systems using UGF

#### Symbols

$R_{sys}$	System Reliability
$R_j$	The reliability of $j^{th}$ subsystem
$X_j$	The state of $j^{th}$ subsystem (either 1=working or 0=down)
$X$	The system structure function

The UGF method is very effective for the reliability analysis of multistate systems; however it could be used for binary-state systems, though that effective as compared to conventional methods (see Kuo & Zuo, 2003).

This section focus on the allocation of UGF technique to reliability systems whose components and the system itself have only 2 states: either working or not.

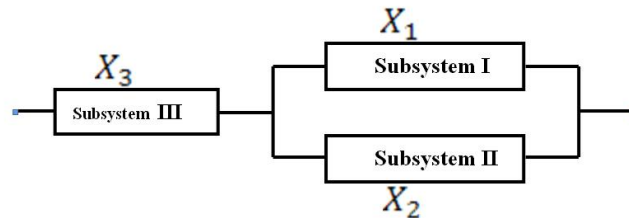

Fig 3-10 The RBD of a series-parallel system  
(Livitin, 2010page 30)

Consider the RBD of a system given in Fig. 3-10 with the system structure function (Livitin, 2010 page 32)

$$X = \min[X_3, \max(X_1, X_2)]$$

where  $X_j$  is the state of  $j^{\text{th}}$  subsystem (with 2 values: either  $x_1=1$ =working or  $x_1=0$ =down).

Let

$R_j=P_j$  be the reliability of  $j^{\text{th}}$  subsystem for a fixed mission time, the probability that is on working conditions during the mission time

and  $1-P_j$  be the probability that the  $j^{\text{th}}$  subsystem is down.

Then the expected value of  $X_j$  is:

$$E(X_j) = 0(1 - P_j) + 1P_j = P_j = R_j$$

where  $R_j$  is  $j^{\text{th}}$  subsystem reliability.

Therefore for a fixed mission time the system reliability equals the expected value of  $X_j$ .

Similarly the reliability of the system for a fixed mission time equals the expected value of the system structure function  $X$ :

$$R_{sys} = E(X), \quad (3-12)$$

Where

$$X = f(X_1, X_2, \dots, X_n)$$

$X_j$  The state of  $j^{\text{th}}$  subsystem (either 1=working or 0=failed)

Therefore for a fixed mission time the system reliability equals the expected value of  $X$ .



Usually the element reliability vector is known and we would like to obtain the system reliability as a function of  $R_j$ 's . In systems with independent elements, such functions are available and depend on the system structure.

**Example 3-8**(Livitin, 2010Page 31)

Consider the following RBD,  $X_j$  denotes the state variable of  $j^{\text{th}}$  subsystem taking values  $x_i = 0$  or  $1$ .

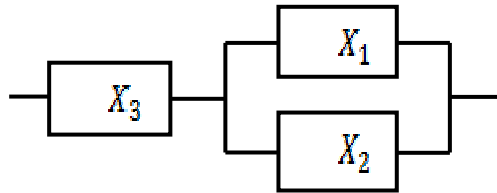

Let the static reliability of  $j^{\text{th}}$  subsystem =  $R_j$  , then

$$Pr(X_j = x_i) = R_j^{x_i}(1 - R_j)^{1-x_i} \quad x_i = 0 \text{ or } x_i = 1 \quad j = 1,2,3$$

If the subsystems are independent then:

$$Pr(X_1 = x_i \cap X_2 = x_i \cap X_3 = x_i) = [R_1^{x_i}(1 - R_1)^{1-x_i}][R_2^{x_i}(1 - R_2)^{1-x_i}][R_3^{x_i}(1 - R_3)^{1-x_i}]$$

Suppose the system structure function or system state variable is  $X = \min[X_3, \max(X_1, X_2)]$ , then the probability function of  $X$  is as the following table shows:

$X_1, X_2, X_3$ $x_i = 0$ down, $x_i = 1$ working	value of	$\Pr( X = x ) = p_x ( x )$
0,0,0	0	$(1 - R_1)(1 - R_2)(1 - R_3)$
0,0,1	0	$(1 - R_1)(1 - R_2)R_3$
0,1,0	0	$(1 - R_1)R_2(1 - R_3)$
0,1,1	1	$(1 - R_1)R_2R_3$
1,0,0	0	$R_1(1 - R_2)(1 - R_3)$
1,0,1	1	$R_1(1 - R_2)R_3$
1,1,0	0	$R_1R_2(1 - R_3)$
1,1,1	1	$R_1R_2R_3$

According to Eq. 3-12 for a binary system :

$$R_{sys} = E(X) = \sum xp_x(x) = [(1 - R_1)(1 - R_2)(1 - R_3) \times 0] + \dots + [R_1R_2R_3 \times 1]$$

$$\Rightarrow$$

$$R_{sys} = (R_1 + R_2 - R_1R_2)R_3 = R_3[1 - (1 - R_1)(1 - R_2)].$$

If in this binary system  $R_1=0.95$ ;  $R_2=0.9$ ;  $R_3=0.85$  , the system reliability would be:

$$R_3 * (1 - (1 - R_1) * (1 - R_2)) = 0.8458 \blacktriangle$$

Having the reliability functions of independent system elements  $R_j(t)$  ( $1 \leq j \leq n$ ) one can obtain the system reliability function  $R_{sys}(t)$  by substituting  $R_j$  with  $R_j(t)$  (Livitin 2010,p32)

**Example 3-9**

Consider the system form previous example whose RBD is

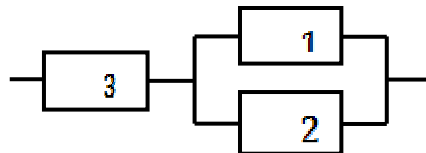

and assume that the reliability functions of the system element are:

$$R_1(t) = e^{-\lambda_1 t} \quad R_2(t) = e^{-\lambda_2 t} \quad R_3(t) = e^{-\lambda_3 t}$$

Then this series-parallel system reliability is:

$$R_{sys}(t) = E\{X(t)\} = R_3(t)[R_1(t) + R_2(t) - R_1(t)R_2(t)] = e^{-\lambda_3 t} [e^{-\lambda_1 t} + e^{-\lambda_2 t} - e^{-(\lambda_1 + \lambda_2)t}], \text{ or}$$

$$R(t) = R_3(t)[1 - (1 - R_1(t))(1 - R_2(t))] = e^{-\lambda_3 t} [1 - (1 - e^{-\lambda_1 t})(1 - e^{-\lambda_2 t})]$$

End of Example ▲

At the end, it is worth mentioning that having the u-functions of the elements of an n-element binary system of the form

$$U_j(Z) = (1 - R_j)Z^0 + R_jZ^1 \quad 0 \leq j \leq n \quad (3-13)$$

and the system structure function  $X = \Phi(X_1, X_2, \dots, X_n)$

The system reliability measure can now be obtained as (Livitin, 2010, page 34):

$$E(X) = U'(1) = \left. \frac{dU(z)}{dz} \right|_{z=1} \quad (3-14)$$

where  $U(z) = \otimes_{\phi} [U_1(z), \dots, U_n(z)]$ .

The application of UGF technique to n-element binary system is discussed in references such as Livitin (2010) pages 32-41. Moreover Wei-Chang (2009) is a reference on UGF.

## Exercises

1. Consider the system given below, composed of 4 like elements having discrete life time of 20, 10 and 30 days with probabilities 0.2, 0.3 and 0.4 respectively.

0.3 and 0.5. Calculate the UGF or  $U(z)$  of this system and the 10-day reliability of the system.

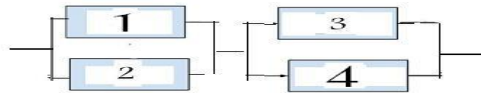

2. Repeat the previous example for the following RBD:

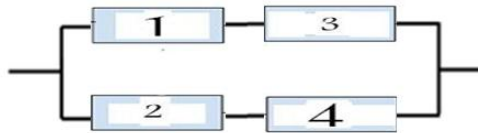

Keep in mind  
that you are  
never absent  
from  
God's sight,  
so keep looking  
how you are  
acting

# Chapter 4

# Structural

# reliability

# Analysis

# 4

## Structural Reliability Analysis

### Aims of the chapter

This chapter focuses on the reliability of the networks and structures whose strength (capacity) and/or loads are probabilistic. Reliability expressions for various statistical distributions of strength and load namely normal, exponential, lognormal, gamma and Weibull are presented.

### 4.1 Introduction

Designers of systems such as structures take many factors into considerations including the reliability. Strength(capacity) and load(stress) are 2 variables that affect the reliability of structures(dams ,bridges; communication networks and antenna). To be reliable, structures require to withstand ultimate loads without failure.

There are 2 approaches for this purpose: deterministic and probabilistic.

The deterministic approach seeks out a worst case and specifies a factor of safety for the extreme case to use in the design. The probabilistic approaches utilize the statistical distribution of input variables (here mainly load and strength) to calculate reliability.

It should be added that in both approaches the amount of data influences the results.

### . Load-strength Interference Analysis

While the deterministic approach adopts the safety factor as stability index, the probabilistic methods adopt as the probability of failure (Queiroz, 2016)

Structural failure occurs when load(stress) exceeds capacity (strength).Figure 1.4 shows such a case.

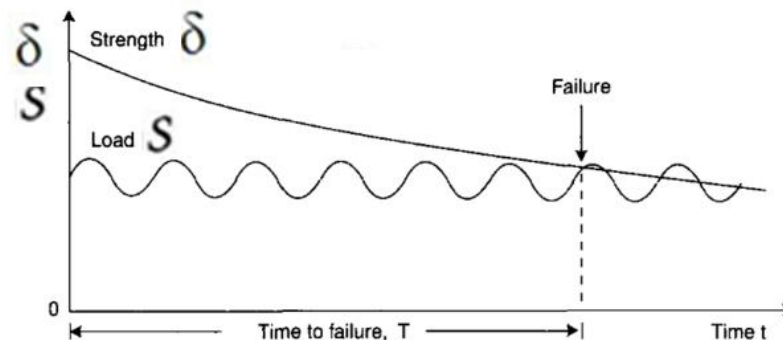

Fig 4-1 The interference of the time-dependent load and strength (Rausand & Hsyland, 2004 Fig 1.2)

### 4-2-1 Deterministic approach: Application of Safety Factor

Safety factor is defined as<sup>1</sup>

$$SF = \frac{\delta}{s} \quad (4-1)$$

where  $\delta$  is the strength and  $s$  is the load.

$SF < 1$  results in failure. An acceptable SF is traditionally 1.5<sup>2</sup>.

To cover unknowns and ensure safety, the deterministic approach introduces conservatism by specifying a largish factor of safety (SF). Calculating such a conservative SF requires a high experience. On the other hand, this approach practically forgets the randomness nature of design variables and parameters (load, strength...). Of course the specialists of this approach may notice the randomness of them but in computations, the specialists act as if they are not probabilistic.

### 4-2-2 Probabilistic Design Approach

The probabilistic approach incorporate the variability of input parameters and variables and utilizes their statistical characterization and attempts to provide a desired reliability in the design. Probabilistic approach uses different methods. In

---

<sup>1</sup> When the strength and load are independent random variables, the average SF,  $E(SF)$ , is approximately:

$$E(SF) \cong \frac{E(\delta)}{E(s)} \left[ 1 + \frac{\sigma_s^2}{E^2(s)} \right]$$

<sup>2</sup> MIL-HDBK-17-3E, Working Draft page 6-7  
<https://www.gla.ac.uk/external/asranet/Resources/milhdbk.pdf>



its simplest form, the measure of reliability is made by comparing a component's stress to its strength(MIL-HDBK-17-3E). The system does not fail as far as load(s) is less than its strength( $\delta$ ) and fails when  $S \geq \delta$ .

### 4-3 System reliability -Load & Strength variable

When the strength ( $\delta$ ) and/or the load(s) are random variables. The reliability( R) of the system is given by

$$R = \Pr(S < \delta) \quad (4-2-1)$$

$$R = \Pr(S - \delta < 0) \quad (4-2-2)$$

$$R = \Pr\left(\frac{\delta}{S} > 1\right) \quad (4-2-3)$$

$$R = \Pr(SF > 1) \quad (4-2-4)$$

Let  $Y = \delta - S$  then

$$R = \Pr(Y > 0) \quad (4-2-5)$$

If the distribution of Y is not known , the following relationship might be helpful:

$$R = \Pr(\delta > S) = \iint_{\delta > S} f_{\delta,S}(\delta, S) d\delta dS, \quad (4-3)$$

where  $f_{\delta,S}(\delta, S)$  is the joint probability density function of strength and load.

If S and  $\delta$  are independent, then:

$$R = \int_{\delta=0}^{\infty} f_{\delta}(\delta) \left[ \int_{s=0}^{\delta} f_s(s) ds \right] d\delta = \int_{s=0}^{\infty} f_s(s) \left[ \int_{\delta=s}^{\infty} f_{\delta}(\delta) d\delta \right] ds \Rightarrow$$

$$R = \int_{s=0}^{\infty} f_s(s) [1 - F_{\delta}(s)] ds \quad (4-4)$$

where

$f_s$       The pdf load

$f_{\delta}$       The pdf strength

$F_{\delta}$       The joint pdf of strength

Moreover, if  $s$  and  $\delta$  are independent, the pdf of  $Y = \delta - S$  might be calculated from (K&L page 125):

$$f_Y(y) = \int_s f_{\delta}(y+s) f_s(s) ds = \begin{cases} \int_0^{\infty} f_{\delta}(y+s) f_s(s) ds & y \geq 0 \\ 0 & \\ \int_{-y}^{\infty} f_{\delta}(y+s) f_s(s) ds & y < 0 \end{cases} \quad (4-5)$$

and the system reliability (R):

$$R = \Pr(Y > 0) = \int_{y=0}^{\infty} f_Y(y) dy = \int_{y=0}^{\infty} \int_{s=0}^{\infty} f_{\delta}(y+s) f_s(s) ds dy \quad (4-6)$$

### Example 4-1

The stress and the strength distributions for a component are uniform over the interval :

Strength: [15 25]

Stress : [20 25]

How many percent of this kind of component break in a single application of the load?

### Solution

$$R = \int_{s=0}^{\infty} f_s(s) [1 - F_\delta(s)] ds = \int_{s=20}^{25} \frac{1}{25-20} \left[ 1 - \frac{s-15}{25-15} \right] ds \Rightarrow$$

$$R = \frac{1}{50} \int_{s=20}^{25} (25-s) ds = 0.25$$

$100(1-R) = 75\%$  break.

End of Example ▲

### 4-3-1 Definition of safety margin(SM)

Safety margin is an index related to the subject of reliability defined as follows:

$$SM = \frac{\mu_\delta - \mu_s}{\sqrt{\sigma_s^2 + \sigma_\delta^2}} \quad (4-7)$$

where

$\mu_\delta$  and  $\mu_s$  are the means of the strength and load,

$\sigma_\delta^2$  and  $\sigma_s^2$  are the variances of the strength and load.

In a structure, if  $S < \delta$ , the more  $s$  far from  $\delta$  the less failure probability and the more reliability. Then the more the denominator the more the reliability; the less variation of the load and strength (or the less the denominator), the more we are confident. Therefore the greater  $SM > 0$ , the more reliable the

structure. It is worth noticing that actually SM equals  $\frac{\mu_Y}{\sigma_Y}$  where  $Y=\delta \cdot S$ . or it equals the reciprocal of the coefficient of variation of Y.

An application of SM is in the calculation of structures' reliability when the strength and the load are independent and normally<sup>1</sup> distributed (See Figs. 4-2-1 & 2)

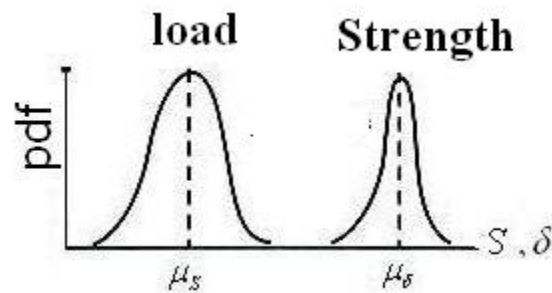

Fig 4-2-1 Normally distributed load and strength: Non- interference

<sup>1</sup> In an exceptional case where the distribution is Weibul(A,B,C) with shape parameter C=3.44, the distribution could be approximated with a normal distribution with parameters (Carter,1986 as reference by O'Connor, 2003 )

$$\mu = A + B\Gamma\left(1 + \frac{1}{C}\right) \cong A + 0.9B, \quad \sigma = B\sqrt{\Gamma\left(1 + \frac{1}{C}\right)} \cong 0.3B$$

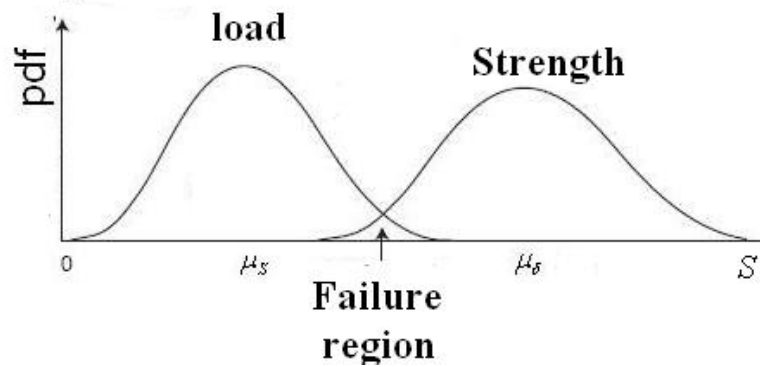

Fig 4-2-1 Normally distributed load and strength: interference

Suppose in a structure

the load is normally distributed with parameters  $\mu_s$  and  $\sigma_s$ .

the strength is normal with parameters  $\mu_\delta$  and  $\sigma_\delta$

the strength and the load are independent.

Then:

$$Y = \delta - S \sim \text{Normal}(\mu_\delta - \mu_s, \sqrt{\sigma_\delta^2 + \sigma_s^2})$$

$$R = \Pr(Y > 0)$$

$$R = \Pr\left(Z > -\frac{\mu_\delta - \mu_s}{\sqrt{\sigma_s^2 + \sigma_\delta^2}}\right) = \Pr\left(Z < \frac{\mu_\delta - \mu_s}{\sqrt{\sigma_s^2 + \sigma_\delta^2}}\right)$$

Since  $\frac{\mu_\delta - \mu_s}{\sqrt{\sigma_s^2 + \sigma_\delta^2}} = SM$  then

$$R = \Phi_Z(SM) \quad (4-8)$$

where  $\Phi_Z$  is the CDF of standard normal distribution.

Therefore when the load and the strength are independent and normally distributed, the reliability( $R$ ) is calculated from Eq. 4-8. The more  $SM$  the greater  $R$ . More specifically on the average the more the difference ((strength-load) or the less the variances of load and strength the more  $R$ . Moreover

- Negative safety margin indicates that on the average load is greater than strength of the structure which is dangerous;

- $|SM|=\infty$  indicated that load and strength are deterministic.

It is worth mentioning that if a random sample of normally distributed strength and a sample of normally distributed load is available, the estimates of the mean and variance of  $S$  and  $\delta$  could be used when using Eqs. 4-7 and 4-8.

### Example 4-1a

The strength and the load related to a structure are normally distributed. Calculate the reliability for  $0,25 < SM < 6$ .

### Solution

The following table shows the reliability calculated from Eq. 4-8 for several  $SM$ . Figure 4-3 shows the related plot.

SM	0	0.25	0.5	0.75	1	1.25	1.5	1.75	2	2.75	3	3.5	4	5	6
$R = \Phi_z(SM)$	.50	.5987	.6915	.7734	.8413	.8944	.9332	.9599	.97725	.9937	.99865	.99977	.999968	.999999	.9999999

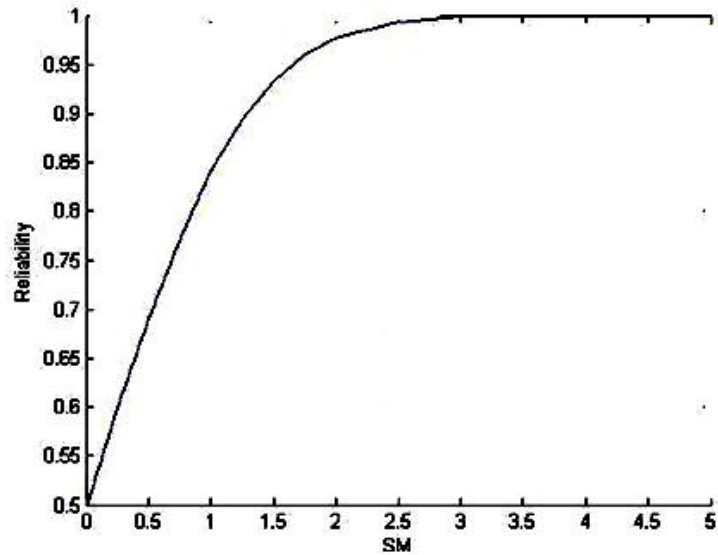

Fig. 4-3 Plot of Reliability versus Safety Margin( K&L page 80 Redrawn)

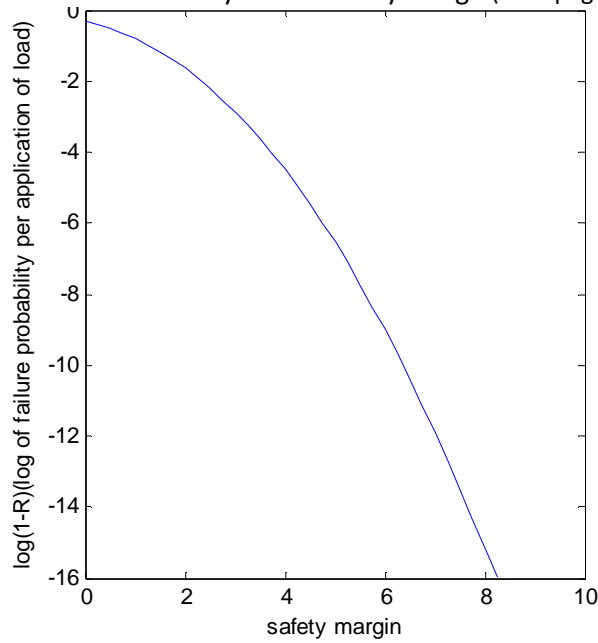

Fig 4-4 Plot of Logarithm of unreliability versus safety margin(SM)

Fig 4-4 shows the logarithm of unreliability ( failure probability) per application of load versus SM. The figure has been plotted using the following MATLAB commands:

$SM = 0:.25:10; R = \text{normcdf}(SM); F = \log_{10}(1-R); \text{plot}(SM, F)$

Table 4.1 gives the reader an idea about the variability in R related to different magnitudes of variability in normally distributed strength and stress random variables (K&L page 79)

Case No.	Strength		Stress		SF	SM	R= $\varphi_Z(SM)$
	$\mu_\delta$	$\sigma_\delta$	$\mu_s$	$\sigma_s$	$\mu_\delta / \mu_s$		
1	50000	2000	20000	2500	2.5	9.37	1.0
2	50000	8000	20000	3000	2.5	3.51	0.9997
3	50000	10000	20000	3000	2.5	2.87	0.9979
4	50000	8000	20000	7500	2.5	2.73	0.9969
5	50000	12000	20000	6,000	2.5	2.236	0.987
6	25000	2000	10000	2500	2.5	4.69	0.9 <sub>(5)</sub> 86
7	25000	1000	10000	1500	2.5	8.32	0.9 <sub>(16)</sub> 6
8	50000	20000	10000	5000	5.0	1.8 <sub>(94)</sub>	0.9738
9	50000	2000	40000	2500	1.25	3.123	0.99909
10	50000	5000	10000	5000	5.0	5.65	0.9 <sub>(8)</sub> 2

End of Example ▲

Figure 5.4 is a sample plot of  $\log(1-R)$  versus SM per application of load. The figure shows if the SM of a design lies in the third region (i.e. if SM is greater than a threshold), the logarithm of failure probability is very small and the failure probability becomes infinitesimal and the design is said to be *intrinsically reliable*.



<b>Table 4-1 Expressions for different independent Distributions of Load (S) &amp; Strength (<math>\delta</math>)</b>				
Case No.	Eq. for reliability	Eq No.	Dist .of Strength( $\delta$ )	Dist .of Load(s)
1	$R = \frac{\lambda_s}{\lambda_s + \lambda_\delta}$	(4-9)	Exp( $\lambda_\delta$ )	Exp( $\lambda_s$ ) Ref:K&L page 157
2	$R = 1 - \exp\left(-\mu \times \lambda + \frac{\sigma^2 \lambda^2}{2}\right)$	(4-10)	Normal ( $\mu, \sigma$ )	Exp( $\lambda$ ) Ref:K&L page 157
3	$SM = \frac{\mu_\delta - \mu_s}{\sqrt{\sigma_\delta^2 + \sigma_s^2}}$ $R = \Phi_Z(SM) = \text{normcdf}(SM)$ Calculable in MATLAB	(4-11)	N( $\sigma_\delta, \mu_\delta$ )	N( $\sigma_s, \mu_s$ ) K&L page 126
4	$R = \Phi_Z(z) = \text{normcdf}(z)$ $z = \frac{\mu_\delta - \mu_s}{\sqrt{\sigma_\delta^2 + \sigma_s^2}}$ $\mu_\delta, \sigma_\delta, \mu_s, \sigma_s$ are the parameters not the mean and standard deviation	(4-12)	logN( $\sigma_\delta, \mu_\delta$ )	logN( $\sigma_s, \mu_s$ ) Ref:K&L page 130
5	$R = \frac{\Gamma(a+b)}{\Gamma(a)\Gamma(b)} \int_{x=\frac{\lambda_s}{\lambda_s+\lambda_\delta}}^{x=\frac{\lambda_s}{\lambda_s+\lambda_\delta}} x^{a-1} (1-x)^{b-1} dx,$ =betacdf( $\frac{\lambda_s}{\lambda_s+\lambda_\delta}, a, b$ ): MATLAB Calculable in MATLAB	(4-13)	Gamma (a, $\lambda_\delta$ )	Gamma (b, $\lambda_s$ ) Ref:K&L page 141
6	$R = \Pr(\delta > s) = \Phi\left(\frac{A-\mu}{\sigma}\right) + \frac{B}{\sigma\sqrt{2\pi}} \times \int_0^\infty \exp[-y^c - 0.5\left(\frac{B}{\sigma}y + \frac{A-\mu}{\sigma}\right)^2] dy,$ $y = \frac{s-A}{B}$ Calculable in Matlab, Maple...	(4-14)	Weibull (A,B,C)	Normal ( $\mu, \sigma$ ) Ref:K&L page 142 & Appendix III
7	$R = 1 - \int_0^\infty e^{-y} \exp\left[-\left(\frac{B_\delta}{B_s} y^{C_\delta} + \frac{A_\delta - A_s}{B_\delta}\right)^{C_s}\right] dy$ $y = \left(\frac{\delta - A_\delta}{B_\delta}\right)^{C_\delta}$ $dy = \frac{C_\delta}{B_\delta} \left(\frac{\delta}{B_\delta}\right)^{C_\delta - 1} d\delta$	(4-15)	Weib( $A_\delta, B_\delta, C_\delta$ )	Weib( $A_s, B_s, C_s$ ) Ref:K&L page 146 In K&L $\frac{A_\delta - A_s}{B_s}$ is seen in the expression which seems to be a typo

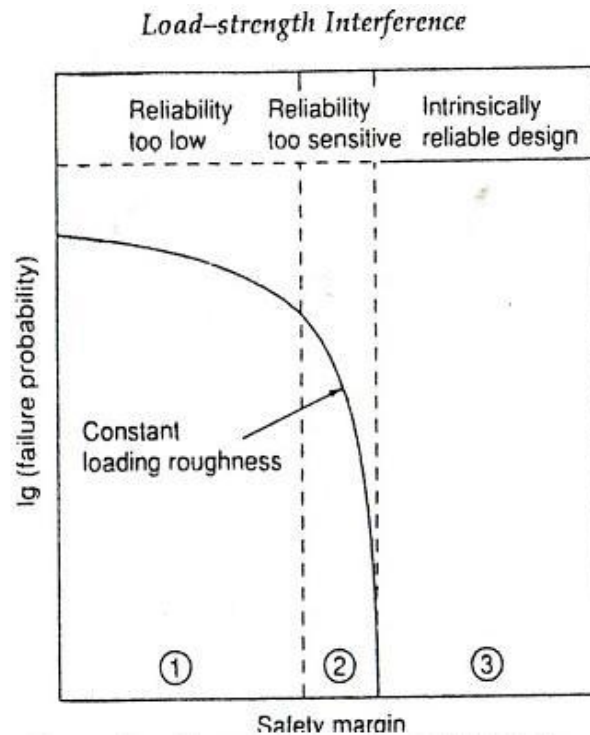

Fig. 4.5 Characteristic regions of a typical  $\log(1-R)$  Vs SM curve  
(O'Connor, 2003 page119)

### Example 4-2

A normally distributed load with parameters  $(\mu, \sigma)$  was applied once to a structure with constant strength,

a) Plot the failure probability ( $F=1-R$ ) versus SM and also plot  $\log(1-R)$  versus SM.

b) Calculate a fixed value ( $\delta$ ) for the strength in terms of  $\mu_s, \sigma_s$  such that the structure lies in the intrinsically reliable region.

**Solution**

$$F = 1 - R = 1 - \Pr(Z < SM),$$

$$SM = \frac{\mu_\delta - \mu_s}{\sqrt{\sigma_s^2 + \sigma_\delta^2}} = \frac{\delta - \mu_s}{\sqrt{\sigma_s^2 + 0}} = \frac{\delta - \mu}{\sigma}$$

The following figure shows failure probability(  $F$  )versus  $SM$  plotted by the following MATLAB commands:

```
SM=.001:.01:8.5 ;F=(1-normcdf(SM)); plot(SM,F)
```

The following figure shows logarithm of  $F$  versus  $SM$  plotted using: `SM=.001:.01:8 ;LF=log(1-normcdf(SM)); plot(SM,LF).`

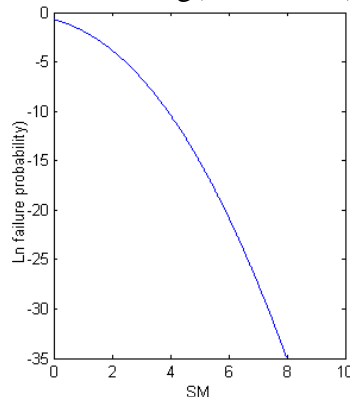

This figure shows that for  $SM > 8$  the structure is intrinsically reliable:

$$\frac{\delta - \mu}{\sigma} = SM > 8 \Rightarrow \delta > \mu + 8\sigma$$

Note that for  $SM = 8$ , the reliability and the failure probability is:

$$F = (1 - R) = 1 \times 10^{-15}$$

$$R = \Pr(Z < SM = 8) = \text{normcdf}(8) = 0.999999999999999 \blacktriangle$$

### 4-3-2 Reliability Computation for Probabilistic independent load and strength

The reference K&L has done a lot of computations for deriving the reliability of systems having various independent distributions of load and strength. Table 4-1 shows the results. It is worth mentioning that

1. exponential distribution could be considered a special form of gamma and Weibull distribution. Therefore if , for example, our structure has a Weibull-distributed load independent from the exponentially distributed strength, then we could use case no. 7 of Table 4-1 to calculate the reliability.
2. If we have a structure with Weibull-distributed load and strength having the same shape parameter C and zero location parameter then the reliability of the structure ( R ) is given by:

$$R = \frac{(B_\delta)^C}{(B_\delta)^C + (B_s)^C} \quad (4-15-1)$$

**Proof:** Form Eq. 4.15

$$y = \left( \frac{\delta - A_\delta}{B_\delta} \right)^{C_\delta}$$

$$\begin{aligned} R = \Pr(\delta > s) &= 1 - \int_0^\infty e^{-y} \exp \left[ -\left( \frac{B_\delta}{B_s} y^{\frac{1}{C}} \right)^C \right] dy \\ &= 1 - \int_0^\infty e^{-y} \exp \left[ -y \left( \frac{B_\delta}{B_s} \right)^C \right] dy \\ &= 1 - \int_0^\infty e^{-\left[ 1 + \left( \frac{B_\delta}{B_s} \right)^C \right] y} dy \Rightarrow \end{aligned}$$

$$\begin{aligned}
 R &= 1 - \int_0^\infty e^{-\left[1 + \left(\frac{B_\delta}{B_s}\right)^c\right] \left(\frac{\delta}{B_\delta}\right)^c} dy, \quad dy = \frac{c}{B_\delta} \left(\frac{\delta}{B_\delta}\right)^{c-1} d\delta \Rightarrow \\
 R &= 1 - \int_0^\infty \frac{c}{B_\delta} \left(\frac{\delta}{B_\delta}\right)^{c-1} e^{-\left[1 + \left(\frac{B_\delta}{B_s}\right)^c\right] \left(\frac{\delta}{B_\delta}\right)^c} d\delta \\
 R &= 1 - \frac{1}{1 + \left(\frac{B_\delta}{B_s}\right)^c} \int_0^\infty \left[1 + \left(\frac{B_\delta}{B_s}\right)^c\right] \frac{c}{B_\delta} \left(\frac{\delta}{B_\delta}\right)^{c-1} e^{-\left[1 + \left(\frac{B_\delta}{B_s}\right)^c\right] \left(\frac{\delta}{B_\delta}\right)^c} d\delta \Rightarrow \\
 R &= 1 - \frac{e^{-\left[1 + \left(\frac{B_\delta}{B_s}\right)^c\right] \left(\frac{\infty}{B_\delta}\right)^c} - e^{-\left[1 + \left(\frac{B_\delta}{B_s}\right)^c\right] (0)^c}}{1 + \left(\frac{B_\delta}{B_s}\right)^c} = 1 - \frac{(B_s)^c}{(B_\delta)^c + (B_s)^c} \\
 \Rightarrow R &= \frac{(B_\delta)^c}{(B_\delta)^c + (B_s)^c} \quad \text{End of proof} \blacksquare
 \end{aligned}$$

### Notice that

-if  $C=1$  i.e. the load and strength are both exponentially distributed with parameters  $\lambda_s = \frac{1}{B_s}$  and  $\lambda_\delta = \frac{1}{B_\delta}$  respectively, then Eq.4.9 is obtained

-if the load and strength are both **Rayleigh** distributed with scale parameters  $B_s$  and  $B_\delta$  respectively, then the reliability is calculated from Eq. 4-15-1 for  $C=1$ :

$$R = \frac{(B_\delta)^2}{(B_\delta)^2 + (B_s)^2} \quad (4-15-2)$$

### Example 4-3-1

A lognormal distributed load with mean of 60000 Kpa and standard deviation of 20000 Kpa is applied to a structure which

has an lognormal distributed strength with a mean of  $10^5$  Kpa and standard deviation of  $10^4$  K pa .

- Find the parameters of th4e distributions:
- Estimate the system's reliability
- Using Eqs. 1-22-1 & 1-22-2 verify the parameters obtained in part a for load distribution.

### Solution

a)Using MALAB software and Eqs. 1-22-5 & 1-22-6 :

$$\sigma_s^2 = \ln \left[ \frac{Var(S)}{E^2(S)} + 1 \right] = \ln \left( \frac{20000^2}{60000^2} + 1 \right) =$$

$$\log(20000^2/60000^2 + 1) = 0.1054$$

$$\mu_s = \ln E(S) - \frac{\sigma_s^2}{2} = \log(60000) - 0.5 \cdot 0.1054 = 10.9494$$

$$\sigma_\delta^2 = \ln \left[ \frac{Var(\delta)}{E^2(\delta)} + 1 \right] = \ln \left( \frac{10000^2}{100000^2} + 1 \right) = \log \left( \frac{10000^2}{100000^2} + 1 \right) = 0.01$$

$$\mu_\delta = \ln E(\delta) - \frac{\sigma_\delta^2}{2} = \log(100000) - 0.5 \cdot 0.01 = 11.5079$$

b) Using MALAB software and Eq. 4-12:

$$R = \phi_z(z) = \text{normcdf}(z) \quad z = \frac{\mu_\delta - \mu_s}{\sqrt{\sigma_\delta^2 + \sigma_s^2}}$$

$$z = \frac{\mu_\delta - \mu_s}{\sqrt{\sigma_\delta^2 + \sigma_s^2}} = \frac{11.5079 - 10.9494}{\sqrt{0.01 + 0.1054}} = 1.6441$$

c) According to Eqs. 1-22-2 & 3

$$E(S) = e^{\mu_s + \frac{\sigma_s^2}{2}} = \exp\left(10.9494 + \frac{0.1054}{2}\right) = 60000$$

$$\text{Var}(S) = (e^{2\mu_s + \sigma_s^2})(e^{\sigma_s^2} - 1).$$

$$\sqrt{(e^{2\mu_s + \sigma_s^2})(e^{\sigma_s^2} - 1)} = \text{sqrt}(\exp(2 * 10.9494 + 0.1054) * (\exp(0.1054) - 1)) = 20004.$$

The difference is due to approximations. ▲

### Example 4-3-2

The following random sample is from the load random variable applied to a structure. The values are in KPa.

284.9188	104.1661	20.6819	461.9137	197.4067
159.5707	161.5850	50.4525	130.1263	161.5384
418.1608	29.1977	80.9464	7.0621	76.3582
87.0721	16.6974	64.4067	159.6288	39.7292

The strength is also a random variable, of which is as follows:

115.3541	26.0195	153.8555	264.6725	51.3116
168.7690	214.7956	18.8720	22.9266	139.8943
66.7714	151.4207	164.2746	153.6125	219.3838
149.3005	206.9543	30.3550	91.1805	81.8012

Assuming the 2 random variables are independent, calculate the reliability.

### Solution

Using softwares such as ARENA<sup>1</sup> or goodness-of-fit tests or Q-Q plot help us to consider the load is exponentially distributed with mean 100KPa and know that a Rayleigh distribution with mean 111 or equivalently a Gamma(a=2,  $\lambda_\delta = 0.018$ ) fits the strength. Since the exponential distribution could be considered Gamma(b=1,  $\lambda_s = 0.01$ ), therefore according to Eq. 4-13 the reliability of the structure is:

$$R = \frac{\Gamma(a+b)}{\Gamma(a)\Gamma(b)} \int_{x=0}^{x=\frac{\lambda_s}{\lambda_s+\lambda_\delta}} x^{a-1}(1-x)^{b-1} dx =$$

$$\text{betacdf}\left(\frac{\lambda_s}{\lambda_s+\lambda_\delta}, a, b\right) \quad \text{MATLAB}$$

$$\frac{\Gamma(2+1)}{\Gamma(2)\Gamma(1)} \int_{x=0}^{x=\frac{0.01}{0.01+0.018}} x^{2-1}(1-x)^{1-1} dx = \frac{2}{1 \times 1} \int_{x=0}^{x=\frac{0.01}{0.028}} x(1-x)^0 dx = x^2 \Big|_0^{\frac{0.01}{0.028}} = 0.1276$$

or by MATLAB

$$R = \text{betacdf}\left(\frac{0.01}{0.01+0.018}, 2, 1\right) = 0.1276 \blacktriangle$$

### Example 4-3-3

The strength( $\delta$ ) of a component and the stress (S) applied to it are exponentially distributed with means 150 and 100 psi respectively. Find the reliability( R) of the component using Eqs. 4.9 &4-15.

---

<sup>1</sup> ARENAtools-input analyzer- new-file data file- use existing- fit all



### Solution

From Eq. 4-9:

$$R = \frac{\lambda_s}{\lambda_s + \lambda_\delta} = \frac{\frac{1}{100}}{\frac{1}{100} + \frac{1}{150}} = 0.60$$

From Eq. 4-15:

Since exponential distribution is a special case of Weibull distribution, then

$$C_\delta = C_s = 1 \quad A_\delta = A_s = 0$$

$$R = 1 - \int_0^\infty e^{-y} \exp \left[ -\left( \frac{B_\delta}{B_s} y^{\frac{1}{C_\delta}} \right)^{C_s} \right] dy$$

$$y = \left( \frac{\delta - A_\delta}{B_\delta} \right)^{C_\delta} = \left( \frac{\delta}{B_\delta} \right)^1, \quad \frac{dy}{d\delta} = \frac{C_\delta}{B_\delta} \left( \frac{\delta}{B_\delta} \right)^{C_\delta - 1} \Rightarrow d\delta = \frac{1}{B_\delta} dy \Rightarrow$$

$$R = 1 - \int_0^\infty \left[ \frac{1}{B_\delta} e^{-\left( \frac{\delta}{B_\delta} \right) - \left( \frac{\delta}{B_s} \right)} \right] d\delta$$

Let  $bs = B_s$ ,  $bd = B_\delta$ . Using the following MATLAB

instructions results in  $R = \frac{3}{5}$ .

```
>>bd=150;bs=100;syms x;W=[(1/bd)*exp(-(x/bd)-x/bs)]
```

```
>>R=1- int(W,x,0,inf) ▲
```

### 4-3-3 Definition of Loading Roughness

Load roughness (LR) is a factor in load-strength interference which combines the load information and strength information

(Wu & Xi, 2010)<sup>1</sup>. Quantifies LR is defined as follows (O'Connor & Keleyner, 2012 page 121) :

$$LR = \frac{\sigma_S}{\sqrt{\sigma_\delta^2 + \sigma_S^2}} \quad (4-16)$$

where

$\sigma_S$  is the standard deviation of load(stress) random variable

$\sqrt{\sigma_\delta^2 + \sigma_S^2}$  is the standard deviation of the difference  $\delta - S$ .

An application of LR is in the calculation of the failure and reliability of components and systems subject to multiple application of loads. The most reliable situations are those with low LR and high SM; and the least reliable situations are those with high LR and low SM (Reuben, 1994 page 209-210).

SM and LR allow, in theory, to analyze the way in which load and strength distributions interfere and so generate a probability of failure (O'Connor & Keleyner, 2012 page 121).

---

<sup>1</sup> Wu, Y. Xi, L. 2010 Load-roughness impact on reliability considering dependent failure, Proceeding 16<sup>th</sup> ISSAT conference on Reliability and Quality in Design

Moreover a value of LR allows to know about the variations of S and  $\delta$  such that:

For a largish SM, if the variance of load is small and that of strength is large then LR will be small (e.g. 0.3); and for a fixed SM, as the load spread becomes wider than that of the strength, LR increases. Therefore for a largish SM if the variance of load is large and that of strength is small then LR will be large (e.g. 0.9).

Figure 4-6 shows four cases in which the distributions of strength and load are normal and have no considerable overlap. The LR for each case is indicated on the figure; SM=4.5 and single application of load results in a reliability of  $\Phi_z(4.5) = 0.999997$ . This figure also shows that:

a) For SM=4.5 if we know that LR is small, it is concluded the variation of strength and load is large and small respectively.

a) For SM=4.5 if we know that LR is large, it is concluded the variation of strength and load is small and large respectively.

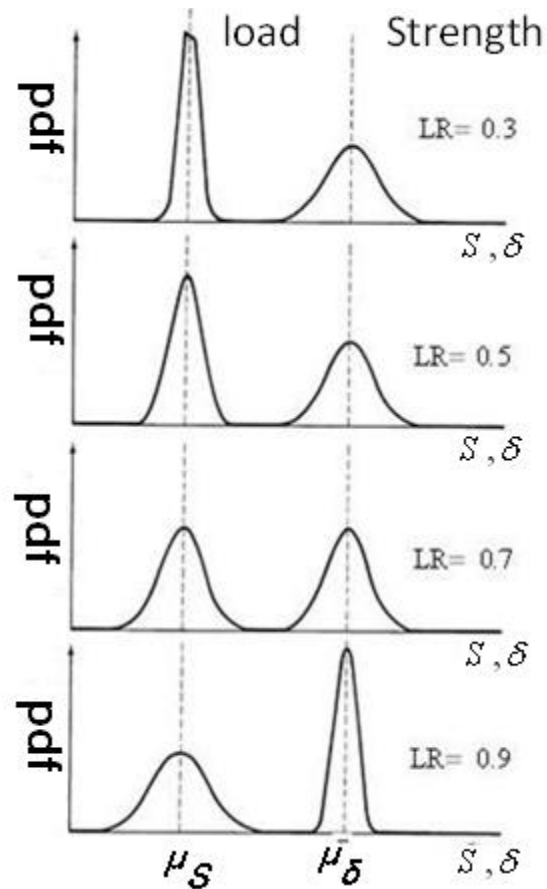

Fig. 4.6 Four cases of normally distributed load and strength with  $SM=4.5$  and 4 different LRs(King,1990 page 348)

To study more about the effects of loading roughness and safety margin, refer to O'Connor & Keleyner(2012) Fig5.2.

**Example 4.4**(O'Connor,2003Example 4-1)

The strength of a component is normally distributed :  $\delta \sim N(5000N, 400N)$ . The load it has to withstand is also normally distributed  $S \sim N(3500N, 400N)$ . Assume the strength is independent of the load.

- a) What is the component reliability per application of load?  
 b) Find the extreme load  $L$  such that  $\Pr(\delta > L)$  equals the answer in part a.

### Solution

a)

$$R = \Pr(Z \leq SM) = \Pr\left(Z \leq \frac{5000 - 3500}{\sqrt{400^2 + 400^2}}\right) = 0.99598$$

b)

$$R = \Pr(\delta > L) = 0.99598 \Rightarrow \Pr\left(Z < \frac{L - 5000}{400}\right) = 0.00402 \Rightarrow$$

$$\frac{L - 5000}{400} = -2/65 \Rightarrow L = 3940 \text{ N}$$

or by MATLAB

$$L = \text{norminv}(1 - 0.99598, 5000, 400) = 3939.85 \text{ N} \blacktriangle$$

### 4.3-4 Effect of Safety Margin and Loading Roughness on Reliability (Multiple Load Applications)

The reliability for multiple load application is calculated from (O'Connor, Kleyner, 2014 page 124):

$$R = \int_{\delta=0}^{\infty} f_{\delta}(\delta) \left[ \int_{s=0}^{\delta} f_s(s) ds \right]^n d\delta \quad (4-17)$$

where

$n$  is loading times, the number of load applications which are independent

$f_s(s)$  is the load pdf and

$f_{\delta}(\delta)$  is the strength pdf independent from the load.

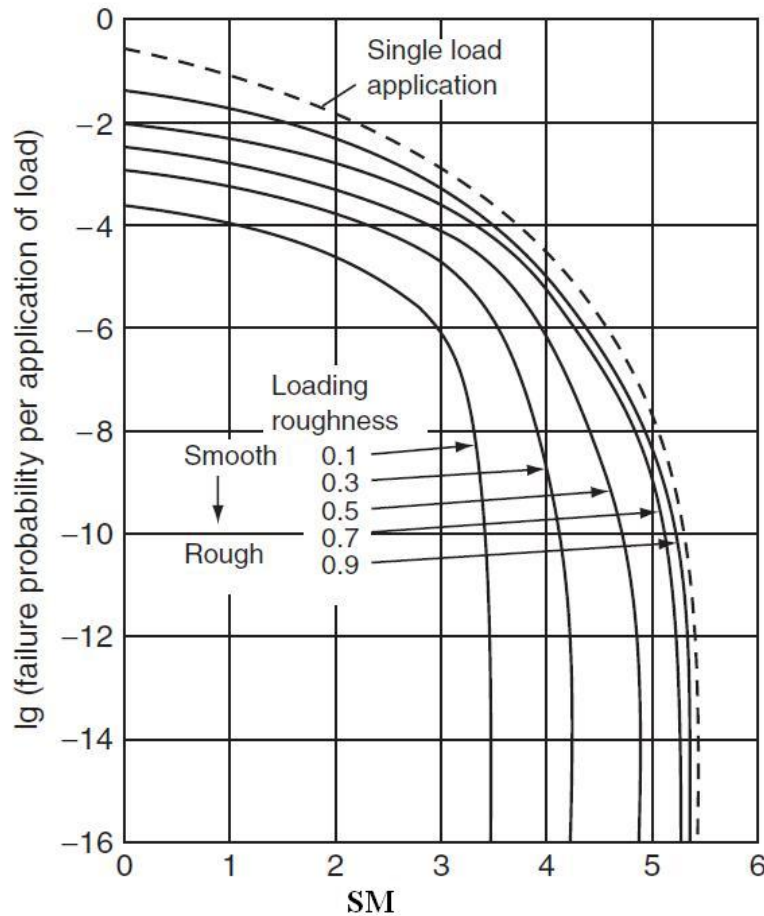

### load and strength are independent and normal

Fig 4-8 Failure probability versus SM for large  $n$  as well as  $n=1$   
(O'Connor, Kleyner, 2014 page 125)

Figure 4.8 shows the effects of different values of LR and SM on failure probability per load application for large values of  $n$  as well for single load application ( $n=1$ ).

For details refer to O'Connor & Kleyner (2014) and Wenxue Qian et al (2014). Wenxue studies the reliability of a com-

ponent in relation to some parameters including LR, SM and loading times(n). O'Connor gives 2 examples which illustrate the application of load-strength analysis to design of an electronic device and a mechanical one.

#### 4-4 Calculation of structures' reliability : Load or Strength deterministic

In this section those systems are considered in which the capacity has known deterministic value and the load is a random variable or vice versa the load is known and the capacity is a random variable.

##### 4-4-1 Calculation of structures' reliability when strength is deterministic

Consider a system with a known capacity  $\delta$  and a distribution of possible loads as plotted in Fig. 4.11.

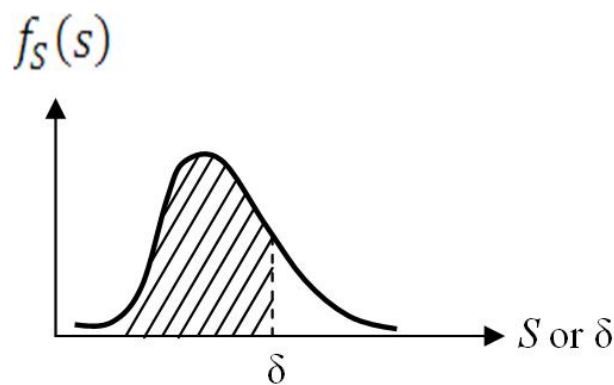

Fig . 4-11 Interpretation of reliability -Load :variable, strength: fixed

For a fixed  $\delta$  if the probability density function of load is  $f_s(s)$  and the CDF is  $F_s(s)$  then the reliability of the system ( R ) is the shaded area in the figure calculated as follows:

$$R = \Pr(S < \delta) = F_s(\delta) = \int_0^{\delta} f_s(s) ds \quad (4 - 18)$$

**Example 4-6** (Lewis, 1994 p181)

Suppose the bending moment on a match stick during striking has an exponential distribution. The match stick have the given strength  $\delta$  and break 20% of the time. The manufacturer increases the strength by 50%. What fraction of the strengthened matches are expected to break as they are struck?

### Solution

Bending moment  $S \sim \exp(\lambda)$ ,

$$R = F_s(\delta) = \int_0^{\delta} f_s(s) ds = \int_0^{\delta} \lambda e^{-\lambda s} ds = 1 - e^{-\lambda \delta}$$

$$0.8 = 1 - e^{-\lambda \delta} \Rightarrow e^{-\lambda \delta} = 0.2$$

Now the strength is multiplied by 1.5 i.e.  $\delta_{\text{new}} = 1.5 \delta$

then

$$\text{NewR} = \int_0^{1.5\delta} \lambda e^{-\lambda s} ds = 1 - e^{-1.5\lambda \delta} = 1 - (e^{-\lambda \delta})^{1.5} = 1 - (0.2)^{1.5} = 0.911$$

The fraction of the strengthened matches expected to break is  $1 - 0.911 = 8.9\%$  ▲



#### 4-4-2 Calculation of structures' reliability when load is deterministic

Consider a system with a known load  $S$  and a distribution of the strength as plotted in Fig. 4.12.

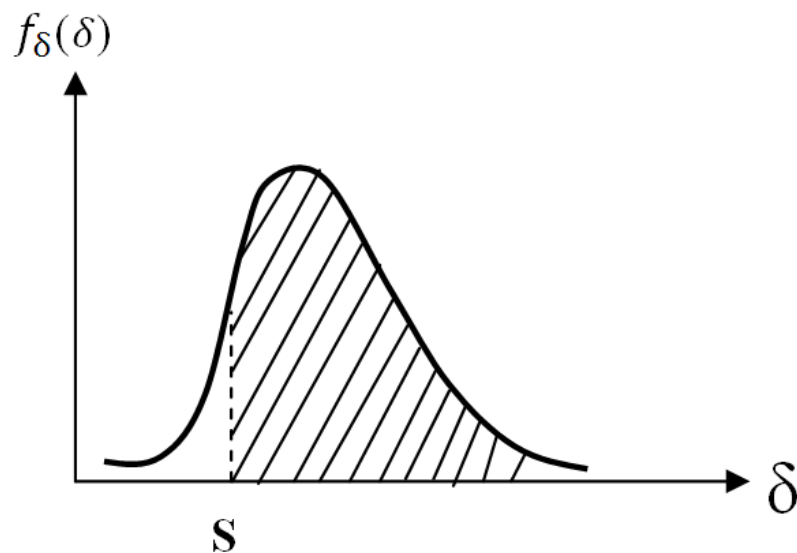

Fig. 4-12 Interpretation of reliability - strength: variable, load: fixed

For a fixed  $S$  if the probability density function of strength (capacity) is  $f_{\delta}(\delta)$  and the CDF is  $F_{\delta}$  then the reliability of the system ( $R$ ) is the shaded area in the figure calculated as follows:

$$R = \Pr(\delta > S) = \int_S^{\infty} f_{\delta}(\delta) d\delta = 1 - F_{\delta}(S) \quad (4-19)$$

#### Example 4-7

A component is subject to the fixed load of 4000N. The strength is log-normally distributed with mean of 5000N and

standard deviation of 400N. Calculate the reliability for single load application.

### Solution

To find the answer we have to calculate the parameters  $\mu$  &  $\sigma$  from the mean and standard deviation using Eq.1-22:

$$\sigma = \sqrt{\ln[\text{var}(X) / E^2(X) + 1]} =$$

using MATLAB

$$\sigma = \text{sqrt}(\log(400^2 / 5000^2 + 1)) = 0.1$$

$$\mu = \ln E(X) - \frac{\sigma^2}{2} = \ln(5000) - \frac{0.01}{2} = 8.5122$$

$$R = \Pr(\delta > S = 4000) =$$

$$\Pr(\ln \delta > \ln 4000 = 8.294) = \Pr(Z > \frac{8.294 - 8.5122}{0.1} = -2.182) = 0.9854$$

or using MATLAB:

$$R = 1 - \Pr(\delta < 4000) = 1 - \text{logncdf}(4000, 8.5122, 0.1) = 0.9854$$

End of Example ▲

### 4-5 Interrelation between reliability(R) and safety factor(SF): Strength( $\delta$ ) and Load(S) independent and normally distributed

Two different methods were pointed out in this chapter to cope with load-strength interference: the reliability-based and safety factor (SF) methods. Are the safety factor and the reliability concepts contradictory or they are interrelated? To answer this question note  $SF = \frac{\delta}{S}$  therefore if the load(S) and the strength( $\delta$ ) are random variables then SF would be a random variable. The following 2 inequalities has been developed to show the interrelation of random variable SF(having a mean of  $\bar{n}$  and coefficient of variation  $V_n$ ) and the system reliability(R). If S and R are independent and normally distributed, then (Dao-Thein&Massoud,1974):

$$\bar{n} \geq \frac{1}{1-V_n \sqrt{\frac{R}{1-R}}} \quad (4-20)$$

$$R \geq 1 - \frac{\bar{n}^2 \times V_n^2}{\bar{n}^2 V_n^2 + (\bar{n}-1)^2} \quad (4-21)$$

where

R      The system reliability

$\bar{n}$      The mean of SF

$$V_n = V_n = \frac{\sigma_{SF}}{\bar{n}}$$

If  $S$  and  $\delta$  are independent with mean and standard deviation of  $(\mu_s, \sigma_s)$  &  $(\mu_\delta, \sigma_\delta)$ , Based on Eqs. 5-12-1 ,5-12-3 the mean and variance of  $SF = \frac{\delta}{S}$  could be approximated from:

$$\bar{n} \cong \frac{\mu_\delta}{\mu_s} \left[ 1 + \frac{\sigma_s^2}{\mu_s^2} \right] \quad (4-22-1)$$

$$\sigma_{SF}^2 \cong \left( \frac{\mu_\delta}{\mu_s} \right)^2 \left[ \left( \frac{\sigma_\delta}{\mu_\delta} \right)^2 + \left( \frac{\sigma_s}{\mu_s} \right)^2 - \left( \frac{\sigma_s}{\mu_s} \right)^4 \right] \quad (4-22-2)$$

Inequalities 4-20&4-21 give a lower bound for  $\bar{n}$  and  $R$  respectively. The relationship between the reliability( $R$ ),  $V_n$  and the lower bound of  $\bar{n}$  is shown in Fig. 4-13.

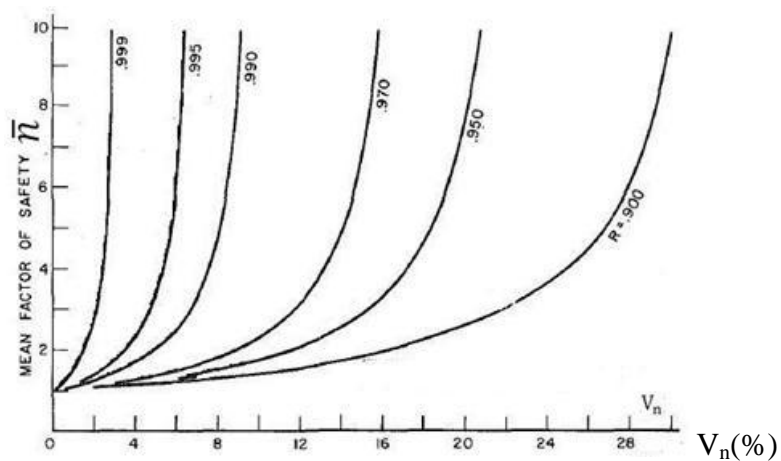

Fig 4.13 Plot of  $\bar{n} = \frac{1}{1 - V_n \sqrt{\frac{R}{1-R}}}$  versus  $V_n$  for six levels of  $R$

(Dao-Thein & Massoud,1974)

According to this figure the reliabilities of 90% , 95%, 97% with  $V_n = 16\%$  corresponds to the average safety factor of at least 2,3 and 10 respectively.

It is worth mentioning that if the load and strength have normal distributions  $S \sim N(\mu_s, \sigma_s)$  and  $\delta \sim N(\mu_\delta, \sigma_\delta)$  then (Handbook Sharpe, 2008 page 271):

$$R = \Phi_Z\left(\frac{\mu_\delta - \bar{n} \times \mu_s}{\sqrt{\sigma_\delta^2 + \sigma_s^2}}\right) \quad (4-23)$$

$\Phi_Z$  is the standard normal distribution that could read from Table C or calculated using a software such as MATLAB.

Needless to say  $\bar{n} = 1$  results in Eq. 4.8. references such as Lewis(1994)page 182 has more on SF and R.

### Example 4-8-1

The safety factor (SF)of a structure is a random variable with a standard deviation of 0.8357. The mean of SF is at least 4.4626. Find the reliability of the structure.

### Solution

From Fig. 4-21 the minimum of the reliability is 0.95. using Inequality 4-21:

$$V_n = \frac{\sigma_{SF}}{\mu_{SF}} = \frac{0.8357}{4.6426} = 0.18$$

$$R \geq 1 - \frac{4.6426^2 * 0.18^2}{4.6426^2 * 0.18^2 + (4.6426 - 1)^2} = 0.95.$$

End of Example ▲

**Example 4-8-1**

The reliability of a structure should be at least 0.95 . the coefficient of variation is 18%. How much is the safety factor on average?

**Solution**

$$\text{Eq. 4-20} \Rightarrow \bar{n} \geq \frac{1}{1 - 0.18 * \text{sqrt}\left(\frac{0.95}{1 - 0.95}\right)} = 4.6426$$

End of Example ▲

### 4-6 Determining the structural reliability bounds using nonlinear programming(NLP)

In the real world, it might be difficult to know the true distributions over the complete range of the stress and the strength random variables(K&L page 88); Therefore the reliability cannot be calculated using Eq. 4-3 i.e.

$$R = \Pr(\delta > S) = \iint_{\delta > S} f_{\delta, S}(\delta, S) d\delta dS$$

or equivalently, in the case of independence of stress and strength, the failure probability cannot be computed from:

$$\bar{R} = \Pr(S > \delta) = \int_{-\infty}^{\infty} F_{\delta}(s) f_s(s) ds = \int_{-\infty}^{\infty} [1 - F_s(\delta)] f_{\delta}(\delta) d\delta \quad (4-24)$$

Where

$f_{\delta, S}(\delta, S)$  Joint pdf of the strength and stress(load)

$f_S$	pdf of the stress(load)
$F_S$	CDF of the stress(load)
$F_\delta$	CDF of the strength
$f_\delta$	pdf of the strength

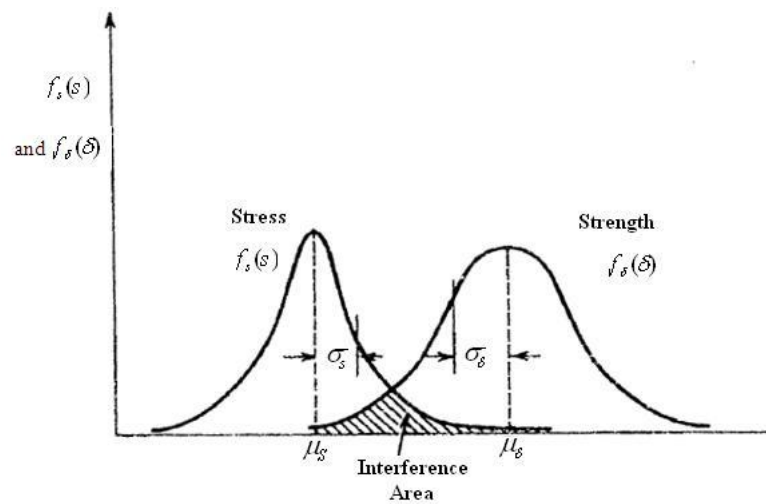

Fig. 4-14 Load- strength interference (K&L page123)

A procedure has been developed for these cases which calculates a minimum and a maximum for the reliability. Note that the reliability( $R$ ) depends on the interference of the two random variables(stress and strength); hence only the local information in the interference range is needed to compute  $R$  (K&L page 88). In this procedure  $s_{\max}$  and  $\delta_{\min}$  are determined as the upper limit for  $S$  and the lower limit for  $\delta$  respectively forming the interference interval  $[\delta_{\min}, s_{\max}]$ .  $\delta_{\min}$  and  $S_{\max}$  are either known from the pdfs of  $\delta$  and  $S$  respectively or their

values are estimated according to the accuracy desired (K&L page 88); then a lower and upper bound is calculated for the reliability according to the following algorithm which uses nonlinear programming (NLP).

#### 4-6-1 The algorithm for Reliability Lower & Upper Bounds using NLP

Step 1

Determine the load-strength interference interval  $[\delta_{\min}, s_{\max}]$  in such a manner that the probability beyond the interval is ignorable.

Now the system failure probability ( $\bar{R}$ ) could be calculated from:

$$\bar{R} = \Pr(s > \delta) \cong \int_{\delta_{\min}}^{s_{\max}} F_{\delta}(u) f_s(u) du = \int_{\delta_{\min}}^{s_{\max}} [1 - F_S(u)] f_{\delta}(u) du \quad (4-25)$$

Step 2

Divide the interval  $[\delta_{\min}, s_{\max}]$  into  $n$  equal subintervals:

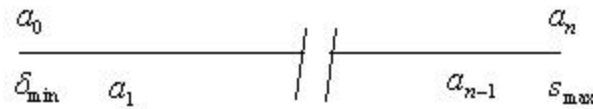

Step 3

Let the probabilities  $(p_1, \dots, p_n)$  and  $(q_1, \dots, q_n)$  be defined as:



$$p_i \equiv \Pr(a_{i-1} < S \leq a_i) \quad i = 1, \dots, n \quad (4-25)$$

$$q_i \equiv \Pr(a_{i-1} < \delta \leq a_i) \quad i = 1, \dots, n \quad (4-26)$$

Now it can be shown that Eq. 4-25 could be approximated by(K&L page89):

$$\bar{R} = \sum_{i=1}^n \left( p_i \left( \sum_{k=1}^i q_k \right) \right) = \sum_{i=1}^n \left( q_i \left( \sum_{k=i}^n p_k \right) \right) \quad (4-27)$$

#### Step 4

$p_i$  and  $q_i$  are the probability of occurring the load and strength in an interval. To add more uncertainty, lower and upper limits could be considered for them:

$$L_{p,i} \leq p_i \leq U_{p,i} \quad i = 1, \dots, n \quad (4-28-1)$$

$$L_{q,i} \leq q_i \leq U_{q,i} \quad i = 1, \dots, n \quad (4-28-2)$$

Therefore in this step determine a lower bound and an upper bound for each of  $(p_1, \dots, p_n)$  &  $(q_1, \dots, q_n)$ . Some designers state these bounds as  $p_i \pm \alpha p_i$  and  $q_i \pm \alpha q_i$  where  $\alpha$  is a fraction between zero and 1.

#### Step 5

Since(K&L page 89):

$$\Pr(\delta \leq s_{\max}) = \sum_{i=1}^n q_i, \quad (4-29-1)$$

$$\Pr(s \geq \delta_{\min}) = \sum_{i=1}^n p_i \quad (4-29-2)$$

and  $\sum p_i$  &  $\sum q_i$  are 2 probability values, to add more uncertainty, consider upper and lower bounds for them:

$$a_p \leq \sum_{i=1}^n p_i \leq b_p, \quad a_q \leq \sum_{i=1}^n q_i \leq b_q$$

Therefore in this step determine bounds for  $\sum p_i$  and  $\sum q_i$

One advice is to locate the bounds  $\pm \frac{\alpha}{2}$  from  $\sum p_i$  or  $\sum q_i$ .

### Step 6

Now we would like to use the above bounds in order to determine the upper and lower bounds for  $\bar{R}$  and for  $R=1-\bar{R}$ . To accomplish this the following 2 nonlinear models have to be developed and solved:

$$\text{Max/Min } \bar{R} = \sum_{i=1}^n \left( p_i \left( \sum_{k=1}^i q_k \right) \right) = \sum_{i=1}^n \left( q_i \left( \sum_{k=i}^n p_k \right) \right)$$

*s t.*

$$L_{p,i} \leq p_i \leq U_{p,i} \quad i = 1, \dots, n$$

$$L_{q,i} \leq q_i \leq U_{q,i} \quad i = 1, \dots, n$$

$$a_p \leq \sum_{i=1}^n p_i \leq b_p,$$

$$a_q \leq \sum_{i=1}^n q_i \leq b_q$$

$$p_i \geq 0 \quad q_i \geq 0$$

Use the optimal values of the 2 objective functions as the lower and upper bounds for the failure probability of the system ( $\bar{R}$ ).

End of algorithm.

It should be pointed out that some researchers have used linear programming to calculate bounds for reliability e.g. see Song & Kiureghian(2003)

#### **Example 4-9**(K&L page 89)

The load on a structure is normally distributed with mean 30MPa and standard deviation 3MPa(coefficient of variation equal to 0.1). The strength has a Weibull distribution with CDF

$$F(t) = 1 - e^{-\left(\frac{t-A}{B}\right)^C} \text{ and parameters:}$$

Minimum strength  $A = 30 \text{ MPa}$ ,  $B = 60 \text{ MPa}$ ,  $C=2$  or  $3$  or  $4$

Find the lower and upper bound for the reliability of this structure.

### Solution

**Step 1**  $[\delta_{\min} \ S_{\max}] = ?$

$\delta_{\min}$  is set equal to  $A=30$ . If we set  $S_{\max} = 50$  based on  $\mu_s + 6\sigma_s = 48$ , the probability that the load reaches an amount greater than it is infinitesimal ( $1.29 \times 10^{-9}$ ).

**Step 2**

The interval  $[\delta_{\min} = 30, S_{\max} = 50]$  is divided into ten subinterval  
With length  $\frac{50-30}{10} = 2$  and :

$$a_0=30 \quad a_1=32 \quad \dots \quad a_9=48 \quad a_{10}=50$$

**Step 3** Determining  $p_i$ 's &  $q_i$ 's

$p_i$ 's based on the load distribution i.e.  $N(\mu_s=30, \sigma_s=3)$ :

$$p_1 = \Pr(30 \leq s \leq 32) = \Pr(0 \leq Z \leq \frac{32-30}{3}) = 0.2475$$

$$p_2 = \Pr(32 \leq s \leq 34) = \text{normcdf}(34,30,3) - \text{normcdf}(32,30,3) = 0.1613$$

$$p_3 = \text{normcdf}(36,30,3) - \text{normcdf}(34,30,3) = 0.0685$$

$$p_4 = \text{normcdf}(38,30,3) - \text{normcdf}(36,30,3) = 0.0189$$

$$p_5 = \text{normcdf}(40,30,3) - \text{normcdf}(38,30,3) = 0.0034$$

$$p_6 = \text{normcdf}(42,30,3) - \text{normcdf}(40,30,3) = 3.9739 \times 10^{-4}$$

$$p_7 = \text{normcdf}(44,30,3) - \text{normcdf}(42,30,3) = 3.0141 \times 10^{-5}$$

$$p_8 = \text{normcdf}(46,30,3) - \text{normcdf}(44,30,3) = 1.4824 \times 10^{-6}$$

$$p_9 = \Pr(46 \leq s \leq 48)$$

$$= \text{normcdf}(48,30,3) - \text{normcdf}(46,30,3) = 4.7226 \times 10^{-8}$$

$$p_{10} = \Pr(48 \leq s \leq 50) =$$

$$\text{normcdf}(50,30,3) - \text{normcdf}(48,30,3) = 9.7350 \times 10^{-10}$$

Calculation of  $q_i$ 's based on the strength distribution i.e. Weibull with parameters  $A=30, B=60, C=2$

$$\begin{aligned} q_1 &= \Pr(30 \leq \delta \leq 32) = F_{\text{weibul}}(32) - F_{\text{weibul}}(30) = \\ &= \left(1 - \exp\left(\frac{32-30}{60}\right)^2\right) - \left(1 - \exp\left(\frac{30-30}{60}\right)^2\right) = 0.0011 \end{aligned}$$

or

$$wblcdf(32-30, 60, 2) - wblcdf(30-30, 60, 2) = 0.0011$$

$$q_2 = \Pr(32 \leq \delta \leq 34) =$$

$$\exp(-((32-30)/60)^2) - \exp(-((34-30)/60)^2) = 0.0033$$

$$\begin{aligned}
q_3 &= \Pr(34 \leq \delta \leq 36) = 0.0055 \\
q_4 &= \Pr(36 \leq \delta \leq 38) = 0.0077 \\
q_5 &= \Pr(38 \leq \delta \leq 40) = 0.0098 \\
q_6 &= \Pr(40 \leq \delta \leq 42) = 0.0118 \\
q_7 &= \Pr(42 \leq \delta \leq 44) = 0.0138 \\
q_8 &= \Pr(44 \leq \delta \leq 46) = 0.0157 \\
q_9 &= \Pr(46 \leq \delta \leq 48) = 0.0174 \\
q_{10} &= \Pr(48 \leq \delta \leq 50) = F_{weibul}(50) - F_{weibul}(48) \\
&= \left(1 - \exp\left(\frac{50-30}{60}\right)^2\right) - \left(1 - \exp\left(\frac{48-30}{60}\right)^2\right) = 0.0191
\end{aligned}$$

#### Step 4

Suppose an uncertainty of  $\pm \alpha = \pm 2\%$  (K&L page90) was present in  $(p_1, \dots, p_n)$  and  $(q_1, \dots, q_n)$  calculated above; therefore each of  $(p_1, \dots, p_n)$  lies in the interval  $[Lp_i \ Up_i]$  where

$$Up_i = p_i + (0.02) * p_i; \quad Lp_i = p_i - (0.02) * p_i$$

and  $q_i$  lies in the interval  $[Lq_i \ Uq_i]$  where

$$Uq_i = q_i + (0.02) * q_i; \quad Lq_i = q_i - (0.02) * q_i$$

As sample calculations the bounds for  $(p_1, p_2, p_3, p_{10})$  are:

$$Up_1 = 0.2475 + (0.02) * 0.2475; \quad Lp_1 = 0.2475 - (0.02) * 0.2475;$$

$$Up_2 = 0.1613 + (0.02) * 0.1613; \quad Lp_2 = 0.1613 - (0.02) * 0.1613;$$

$$Up_3 = 0.0685 + (0.02) * 0.0685; \quad Lp_3 = 0.0685 - (0.02) * 0.0685;$$

$$U_{p_{10}} = 9.7350 \times 10^{-10} + (0.02) * 9.7350 \times 10^{-10} ;$$

$$L_{p_{10}} = 9.7350 \times 10^{-10} - (0.02) * 9.7350 \times 10^{-10} ;$$

The bounds for  $(q_1, \dots, q_{10})$  with  $\pm (\alpha = 2\%)$  are calculated from

$$U_{q_i} = q_i + (0.02) * q_i ; \quad L_{q_i} = q_i - (0.02) * q_i \quad i=1,2,\dots,10$$

As sample calculation:

$$q_1 = 0.0011; U_{q_1} = 0.0011 + (0.02) * 0.0011; L_{q_1} = 0.0011 - (0.02) * 0.0011$$

**Step 5** Calculation of  $\sum p_i$  and  $\sum q_i$  and their limits

$$\sum_{i=1}^n p_i = \Pr(s \geq \delta_{\min}) = \Pr(Z > \frac{30-30}{3}) = 0.5$$

$$\sum_{i=1}^n q_i = \Pr(\delta \leq s_{\max}) = 1 - \exp[-(\frac{50-30}{60})^2] = 0.105.$$

Suppose an uncertainty of 1% was present in  $\sum q_i$  and  $\sum p_i$

calculated above (K&L page 90); therefore they lie in the following intervals (K&L page 90):

$$0.5 - (\frac{0.02}{2}) \times 0.5 \leq \sum_{i=1}^n p_i \leq 0.5 + (\frac{0.02}{2}) \times 0.5$$

$$0.105 - (\frac{0.02}{2}) \times 0.105 \leq \sum_{i=1}^n q_i \leq 0.105 + (\frac{0.02}{2}) \times 0.105$$

The following MATLAB code performs steps 3, 4 and 5:

```
format long
%input
r=[30 50]; %input 1
n=10; %input 2
alpha=0.02; %input 3
%algorithm
a=alpha;% specify an appropriate value for alpha
x=r(1):(r(2)-r(1))/n:r(2);
for i=1:n
%Load
p(i)=normcdf(x(i+1),30,3)-normcdf(x(i),30,3);
%Strength
q(i)=wblcdf(x(i+1)-30,60,2)-wblcdf(x(i)-30,60,2);
end
p=p';
q=q';
Up=p+p*a
Lp=p-p*a
Uq=q+q*a
Lq=q-q*a
Sigmap=normcdf(min(x),30,3)
Sigmaq=wblcdf(max(x)-30,60,2)
Usingap=Sigmap+a*0.5*Sigmap
Lsigmap=Sigmap-a*0.5*Sigmap
Usigmaq=Sigmaq+a*0.5*Sigmaq
Lsigmaq=Sigmaq-a*0.5*Sigmaq
```



**Step 6** Lower and upper bound for failure probability ( $\bar{R}$ ):

**Step 6-1** The following model has to be solved once for maximization and once again for immunization to find the upper limit for failure probability( $\bar{R}$ ).

The objective function is:

$$\text{Max } \bar{R} = \sum_{i=1}^{10} \left( p_i \left( \sum_{k=1}^{k=i} q_k \right) \right)$$

or

$$\text{Max } \bar{R} = p_1 q_1 + p_2 (q_1 + q_2) + p_3 (q_1 + q_2 + q_3) + \dots + p_{10} (q_1 + q_2 + \dots + q_{10})$$

s.t.

The constraints of type  $L_{p,i} \leq p_i \leq U_{p,i} \quad i = 1, \dots, 10$  :

$$L_{p_1} = 0.2475 - (0.02) \times 0.2475 \leq p_1 \leq U_{p_1} = 0.2475 + (0.02) \times 0.2475$$

$$0.1613 - (0.02) \times 0.1613 \leq p_2 \leq 0.1613 + (0.02) \times 0.1613$$

$$0.0685 - (0.02) \times 0.0685 \leq p_3 \leq 0.0685 + (0.02) \times 0.0685$$

$$0.0189 - (0.02) \times 0.0189 \leq p_4 \leq 0.0189 + (0.02) \times 0.0189$$

$$0.0034 - (0.02) \times 0.0034 \leq p_5 \leq 0.0034 + (0.02) \times 0.0034$$

$$3.9739 \times 10^{-4} - (0.02) \times 3.9739 \times 10^{-4} \leq p_6 \leq 3.9739 \times 10^{-4} + (0.02) \times 3.9739 \times 10^{-4}$$

$$3.0141 \times 10^{-5} - (0.02) \times 3.0141 \times 10^{-5} \leq p_7 \leq 3.0141 \times 10^{-5} + (0.02) \times 3.0141 \times 10^{-5}$$

$$1.4824 \times 10^{-6} - (0.02) \times 1.4824 \times 10^{-6} \leq p_8 \leq 1.4824 \times 10^{-6} + (0.02) \times 1.4824 \times 10^{-6}$$

$$4.7226 \times 10^{-8} - (0.02) \times 4.7226 \times 10^{-8} \leq p_9 \leq 4.7226 \times 10^{-8} + (0.02) \times 4.7226 \times 10^{-8}$$

$$9.7350 \times 10^{-10} - (0.02) \times 9.7350 \times 10^{-10} \leq p_{10} \leq 9.7350 \times 10^{-10} + (0.02) \times 9.7350 \times 10^{-10}$$

The constraints of Type  $L_{q,i} \leq q_i \leq U_{q,i} \quad i = 1, \dots, 10$  :

$$\begin{aligned}
Lq_1=0.0011-(0.02)\times 0.0011 \leq q_1 \leq Uq_1=0.0011+(0.02)\times 0.0011 \\
Lq_2=0.0033-(0.02)\times 0.0033 \leq q_2 \leq Uq_2=0.0033+(0.02)\times 0.0033 \\
Lq_3=0.0055-(0.02)\times 0.0055 \leq q_3 \leq Uq_3=0.0055+(0.02)\times 0.0055 \\
Lq_4=0.0077-(0.02)\times 0.0077 \leq q_4 \leq Uq_4=0.0077+(0.02)\times 0.0077 \\
Lq_5=0.0098-(0.02)\times 0.0098 \leq q_5 \leq Uq_5=0.0098+(0.02)\times 0.0098 \\
Lq_6=0.0118-(0.02)\times 0.0118 \leq q_6 \leq Uq_6=0.0118+(0.02)\times 0.0118 \\
Lq_7=0.0138-(0.02)\times 0.0138 \leq q_7 \leq Uq_7=0.0138+(0.02)\times 0.0138 \\
Lq_8=0.0157-(0.02)\times 0.0157 \leq q_8 \leq Uq_8=0.0157+(0.02)\times 0.0157 \\
Lq_9=0.0174-(0.02)\times 0.0174 \leq q_9 \leq Uq_9=0.0174+(0.02)\times 0.0174 \\
Lq_{10}=0.0191-(0.02)\times 0.0191 \leq q_{10} \leq Uq_{10}=0.0191+(0.02)\times 0.0191
\end{aligned}$$

Constraints related to  $\sum p_i$  &  $\sum q_i$  :

$$a_p \leq \sum_{i=1}^n p_i \leq b_p \quad \equiv \cdot .5-(0.02/2)*0.5 \leq p_1 + \dots + p_{10} \leq 0.5+(0.02/2)*0.5$$

$$a_q \leq \sum_{i=1}^n q_i \leq b_q \quad \equiv 0.1055-(0.02/2)*0.105 \leq q_1 + \dots + q_{10} \leq 0.105+(0.02/2)*0.105$$

$$0 \leq p_i \leq 1 \quad 0 \leq q_i \leq 1$$

Softwares such as Lingo or GAMS give the following results for the maximization and minimization :

The objective function has the optimal values:

If minimized  $\bar{R}_{\min}=0.00704$ = the lower limit

If maximized  $\bar{R}_{\max}=0.0076$ = the upper limit

Therefore for  $\alpha = 2\%$  and the Weibull shape parameter  $C= 2$ , the failure probability lies in [ 0.00704      0.0076] and the reliability lies in:[ 1-0.0076      1-0.00704 ] =[0.9924      0.99295 ].

The following table shows the unreliability limits for other cases(from K&L page 91):

Uncertainty ( $\alpha$ )%	Shape Parameter					
	C=2		C=3		C=4	
	$\bar{R}_{\min}$	$\bar{R}_{\max}$	$\bar{R}_{\min}$	$\bar{R}_{\max}$	$\bar{R}_{\min}$	$\bar{R}_{\max}$
2	<b>0.00704</b>	<b>0.0076</b>	<b>0.00123</b>	<b>0.00133</b>	<b>0.00024</b>	0.00026
4	<b>0.00677</b>	<b>0.00789</b>	<b>0.00118</b>	<b>0.00138</b>	<b>0.00023</b>	<b>0.00027</b>
6	<b>0.00650</b>	<b>0.00818</b>	<b>0.00113</b>	<b>0.00143</b>	<b>0.00022</b>	<b>0.00029</b>
8	<b>0.00624</b>	<b>0.00848</b>	<b>0.00108</b>	<b>0.00148</b>	<b>0.00021</b>	<b>0.00030</b>
10	<b>0.00598</b>	<b>0.00878</b>	<b>0.00104</b>	<b>0.00154</b>	<b>0.00020</b>	<b>0.00031</b>

End of Example ▲

## Appendix : Other definition of safety margin(SM) and its relationship to safety factor(SM)

As well as the definition given in Eq. 4-7 for safety margin(SM), SM is usually expressed as the allowable working stress ( $f_{mw}$ ) divided by the applied stress  $f$  minus 1 (Ireson et al,1996 page 18-13).

$$SM = \frac{f_{mw}}{f} - 1. \quad (p-1)$$

Any negative SM value indicate that the structure will fail because the applied stress of the allowable material strength. This is only for unidirectional stresses ; biaxial and tri-axial stresses require further analysis(Ireson et al,1996 page 18-13).

It is reminded that the safety factor(SF) which is a strength design factor is defined by the ratio of a critical design strength parameter (tensile, yield, etc) to the anticipated operating stress under normal operating conditions((Ireson et al,1996 page 18-12). For example let

$\delta$  denote the material strength and

$f_{mw}$  denote the allowable working stress

Then the factor of safety becomes:

$$SF = \frac{\delta}{f_{mw}}$$

Therefore  $f_{mw} = \frac{\delta}{SF}$  and:

$$SM = \frac{\delta}{SF \times f} - 1 \quad (\text{p-2}) \quad \text{or}$$

$$SF = \frac{\delta}{(SM+1) \times f} \quad (\text{p-3})$$

where

SM	The safety margin or margin of safety
SF	The safety factor
$\delta$	The strength of the material
$f_{mw}$	The maximum allowable working stress
$f$	The stress applied to the structure.

Have a good opinion of God,  
for whoever has a good opinion of God  
He will treat him in the same way

## Exercises

In the following problems the stress and the load(stress) are independent.

**1-**(Problem 5 Page159 K&L) The strength  $\delta$  and the stress  $S$  for the design of a component are logomrally distributed with the following infonnation on  $\delta$  and  $S$ :

$$E(\delta)=750.00 \text{ Mpa} \quad \sigma_{\delta} =50.00 \text{ MPa}$$

$$E(S)=500.00 \text{ Mpa} \quad \sigma_S =80.00 \text{ Mpa}$$

**2-**(Problem 3Page159 K&L)A component is to be designed for a specified reliability of 0.990. The stress and the strength random variables are known to be lognormally distributed for this component with the following information

$$E(\delta)=1100.00 \text{ MPa}, \quad E(S) = 850.00, \quad \sigma_S =100.00 \text{ MPa}$$

Determine the maximum allowable standard deviation of the stress that can be be appliedto the component which will give us the desired reliability.

**3 -**(Problem 9 Page160 K&L)The strength of a component has a gamma distribution with parameters  $a=4$ ,  $\lambda_{\delta}=1$ . The failure inducing stress also is gamma distributed with  $b=2$ ,  $\lambda_S=1$ . Compute the reliability of the component.

**4-**(Problem 10 Page160 K&L) In Exercise 3, assume that  $\lambda_{\delta}=4$  and  $\lambda_S = 2.5$  . Compute the reliability of the component for this case.

**5-**(Problem 11 Page161 K&L) A leaf spring for a truck is to be designed for a reliability 0.9995 based on the fatigue failure of the leaf spring. The fatigue strength of the material out of which this spring is made is Weibull distributed with the following parameters:

$$A= 500.00 \text{ M Pa} \quad B= 500.00 \text{ M Pa} \quad C=3.0$$

The random loading of the spring induces stresses that are assumed to be normally distributed with a coefficient of variation of 0.08. Compute the permissible normal stress parameters that would yield the specified reliability.

**6-**(Problem 13 Page160 K&L)The strength of a component is lognormally distributed with a mean of 800.00MPa and standard deviation of 150.00 MPa. The failure governing stresses have normal distribution with a mean of 600.00 MPa and a standard deviation of 110.00 MPa. Compute the reliability of the component.

**7-**(Problem 15 Page161 K&L)The stress acting on a component is uniformly distributed over an interval  $\{ 10,40\}$ . Th« strength of

the component follows normal distribution (35 , 5) Derive an expression for the reliability of the component. Find R

**8-**(Problem 16 Page162 K&L)The stress acting on a component is uniformly distributed over [ 10 , 30] The strength of the component has a three-parameter Weibull distribution with parameters  $A=20$ ,  $B=30$  and  $C=3$ . Derive an expression for the reliability of the component and calculate its numerical value.

**9-**(Problem 17 Page162 K&L)The stress acting on a component is uniformly distributed over an interval [ $S_{\min}$   $S_{\max}$ ]. The strength of the component has gamma distribution with parameters  $n$  and  $\lambda$ . Derive an expression for the reliability of the component. Let

$$S_{\min} = 10 \quad S_{\max} = 30 \quad n = 5 \quad \lambda = 0.2$$

Find R.

**10-**(Problem 8 Page160 K&L)The strength of a component is lognormally distributed with a mean value of 400 MPa and a standard deviation of 50 MPa. The stress acting on the component is normally distributed with a mean value of 250 MPa and a standard deviation of 50 MPa. Compute the bounds on reliability for  $\alpha$  equal to 5% .

**11-**(Problem 9 Page160 K&L)

The stress and the strength distributions for a component are Weibull with the following parameters:

Strength:  $A=300$  MPa,  $B=400$  MPa,  $C=3$

Stress :  $A=150$  MPa,  $B=300$  MPa,  $C=4$

Compute the bounds on reliability for  $\alpha=0.05$

**12-** Find the a component reliability with exponentially distributed strength with parameter  $\lambda_\delta = 0.001$  and normally distributed stress  $N(\mu_s = 35\text{Kpa}, \sigma_s = 5\text{Kpa})$  using the following equation (Eq. 6-31K&L p139)

$$R = \phi_z\left(-\frac{\mu_s}{\sigma_s}\right) + \exp\left(\frac{\lambda_\delta^2 \sigma_s^2}{2} - \mu_s \lambda_\delta\right) \times \left[1 - \phi_z\left(-\frac{\mu_s - \lambda_\delta^2 \sigma_s^2}{\sigma_s}\right)\right]$$

$$\text{normcdf}(-35/5) + \exp((.001^2 * 5^2)/35 - 2 * 0.001) * (1 - \text{normcdf}((-35 + (.001^2 * 5^2))/5 - 4))$$

**13-** Is it possible to derive Eq.4.9 from Eq.4-13 or 4-15 of this chapter?



Chapter 5  
on the  
Combination of  
Random Variables  
in Design  
& a Glance at the  
Tolerance Concept

# 5

On the combinations of random variables in design ;  
A glance at the tolerance concept

## Aims of the chapter

This chapter is concerned with finding some properties of a function of several random variables. The chapter also reviews the concept of tolerance in designs quickly.

## 5.1 Introduction

The reliability of an engineering design is often a function of several quantities. Variability is inherent in most of these quantities; i.e. most of them are random variables(RVs). As an example consider the design of a beam. Stresses in beams due to bending is very important for an engineer; therefore he is usually interested in computing the bending stresses. The following formula gives the maximum stress in a beam due to bending(K&L page 95:

$$S = \frac{M \times c}{I} \quad (5-1-1)$$

where

$S$  = the maximum stress at the farthest surface from the neutral axis (it can be at top or at bottom), kPa

$c$  = the maximum distance from the neutral axis to the extreme fiber (again, this can be to the top or bottom of the shape), m

$I$  = the moment of inertia of the beam cross section about the centroidal axis,  $m^4$

$M$  = the bending moment along the length of the beam where the stress is calculated, N.m

if the maximum bending stress is required then  $M$  is the maximum bending moment acting on the beam

The moment of inertia of a beam having circular cross section with radius  $r$  meters and thickness of  $t$  meters is

$I = \pi r^3 t$ . Thus according to Eq. 5-1-1, برابر  $S = \frac{M \times c}{\pi r^3 t}$  gives the

maximum fiber stress in such a beam. If the beam has a rectangular cross-section of height  $a$  meters and width  $b$

meters, then  $I = \frac{ba^3}{12}$  in  $m^4$  and the corresponding stress is

calculated from  $S = 12 \frac{M \times c}{ba^3}$

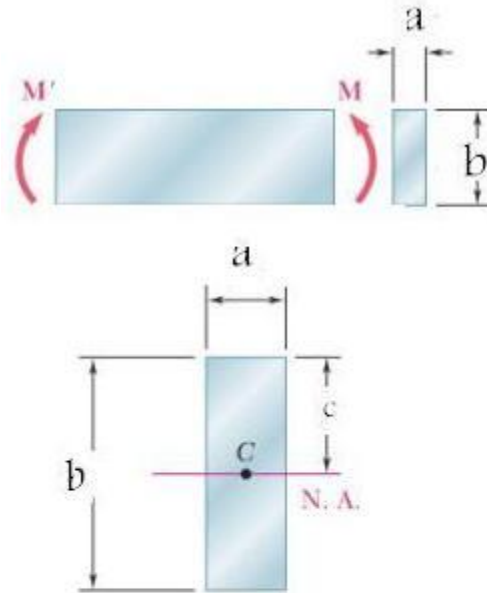

$a=20\text{mm}, b=60\text{ mm}, \sigma_y = 250\text{Mpa}$  **yield stress**

$$I = \frac{1}{12} ab^3 = \frac{1}{12} (20\text{ mm})(60\text{ mm})^3 =$$

$$I = 360 \times 10^3 \text{ mm}^4 = 360 \times 10^3 \left(\frac{\text{m}}{10^3}\right)^4 = 360 \times 10^{-9} \text{ m}^4$$

$$c = \frac{b}{2} = 30\text{mm} = 0.03\text{m}$$

$$M_y = \frac{I}{c} \sigma_y = \left(\frac{360 \times 10^{-9} \text{ m}^4}{0.03}\right) \times (250 \times 10^6 \text{ Pa}) = 3000 \Rightarrow$$

$$M_y = 3000 \text{ Nm} = 3 \text{ kNm} \quad \blacktriangle$$

Fig.5.1 Bending moment on a beam- An illustration

It is worth mentioning that if yield stress(=  $\sigma_y$ ) replaces  $S$ , the external bending moment( $M_y$ ) causing the beam to reach the yield point is calculated as follows:

$$M_y = \frac{1}{c} \sigma_y \quad (5-1-2)$$

Figure 5-1 illustrates this equation.

In real world, quantities such as  $M, c, b$  &  $a$  are random variables. Hence to compute any property of a function of these random variables such as  $S = \frac{M \times c}{I}$ , we need to know how to combine as  $M, c, b, a$ . Now for this reason we focus on how to find certain properties of a function of random variables.

## 5.2 Certain properties of a function of some random variables

In this section, given random variables  $x_1, \dots, x_n$  we are to show how to determine certain properties  $f(x_1, \dots, x_n)$  i.e. a function of them which is in turn a random variable (K&L p 96).

### 5.2.1 The pdf of a function of one random variable

Suppose we are given  $Y = g(X)$  where  $X$  is a random variable with known density function (pdf)  $f(x)$  and we would like to find the pdf  $h(y)$  for the random variable  $Y$ .  $h(y)$  is given by the following relationship (K&L p97):

$$h(y) = \left| \frac{dk}{dy} \right| \times f[k(y)] \quad (5-2)$$

where

$k(y)$  is the inverse function of  $g$  i.e.  $k(y) = g^{-1}(y) = x$ ,

$\left| \frac{dk}{dy} \right|$  represents the absolute value of the derivative of  $k(y)$  with respect to  $y$ .

If  $x = g^{-1}(y)$  has 2 answers  $x_1, x_2$  then

$$h(y) = \left| \frac{dk}{dy} \right| \times f(x_1) + \left| \frac{dk}{dy} \right| \times f(x_2) \quad (5-3)$$

In general, if the inverse function has  $n$  roots  $x_1, \dots, x_n$ , Eq. 5.3 will have  $n$  items, one term for each root(K&L page97).

### Example 5.1

Random variable  $X$  is normally distributed with density function(pdf)  $f(x) = \frac{1}{\sigma\sqrt{2\pi}} e^{-\frac{(x-\mu)^2}{2\sigma^2}}$  and  $Y = e^X$ . Find the pdf of  $Y$ .

### Solution

$$Y = g(X) = e^X,$$

$$\text{pdf of } Y = h(y) = \left| \frac{dk}{dy} \right| \times f[k(y)] , \quad k(y) = g^{-1}(y)$$

$$Y = e^X \implies x = \ln y = k(y) \quad \frac{dk}{dy} = \frac{1}{y}$$

$$f(k(y)) = \frac{1}{\sigma\sqrt{2\pi}} e^{-\frac{(\ln y - \mu)^2}{2\sigma^2}}$$

$$h(y) = \left| \frac{dk}{dy} \right| \times f[k(y)] = \frac{1}{y} \times \frac{1}{\sigma\sqrt{2\pi}} e^{-\frac{(\ln y - \mu)^2}{2\sigma^2}};$$

This is the pdf of lognormal distribution. This is well known in statistics that if random variable  $X$  is normally distributed,  $e^X$  has a lognormal distribution. End of Example ▲

**Example 5.2** (K&L p97)

The diameter(D) of the circular cross section of a kind of rod has a normal distribution with  $f(x) = \frac{1}{\sigma\sqrt{2\pi}} e^{-\frac{(x-\mu)^2}{2\sigma^2}}$ . Find the probability density function of the cross section i.e.  $A = \pi \frac{D^2}{4}$ .

**Solution**

$$A = \pi \frac{D^2}{4} \Rightarrow D_1 = +\sqrt{\frac{4A}{\pi}}, D_2 = -\sqrt{\frac{4A}{\pi}};$$

According to Eq. 5.3:

$$h(y) = \left| \frac{dk}{dy} \right| \times f(x_1) + \left| \frac{dk}{dy} \right| \times f(x_2)$$

Here  $y=A$ ,  $k=D$   $x_2 = D_2$   $x_1 = D_1$  then  $h(A)$ , the pdf of the cross section is calculated from:

$$h(A) = \left| \frac{dD}{dA} \right| \times f\left(+\sqrt{\frac{4A}{\pi}}\right) + \left| \frac{dD}{dA} \right| \times f\left(-\sqrt{\frac{4A}{\pi}}\right)$$

$$D = \pm A^{\frac{1}{2}} \sqrt{\frac{4}{\pi}} \Rightarrow \left| \frac{dD}{dA} \right| = \sqrt{\frac{4}{\pi}} \times \frac{1}{2} \times A^{\frac{1}{2}-1} \Rightarrow \left| \frac{dD}{dA} \right| = \sqrt{\frac{1}{A\pi}}$$

$$h(A) = \sqrt{\frac{1}{A\pi}} \times \frac{1}{\sigma\sqrt{2\pi}} \left[ \exp\left(-\frac{\left(\sqrt{\frac{4A}{\pi}} - \mu\right)^2}{2\sigma^2}\right) + \exp\left(-\frac{\left(-\sqrt{\frac{4A}{\pi}} - \mu\right)^2}{2\sigma^2}\right) \right]$$

End of Example ▲

### 5-2-2 Mean of 2 random variables

If  $X$ ,  $Y$  are random variables( no matter whether continuous or discrete, independent or not) with mean  $\mu_1, \mu_2$  then:

$$E[X+Y]=E[X]+E[Y] \text{ or } \mu_{X+Y} = \mu_1 + \mu_2 \quad (5-4)$$

**Proof for continuous case**(Ross, 1985 p46):

If  $X$  and  $Y$  are continuous random variables with marginal density functions  $f_X(x) \cdot f_Y(y)$  and joint pdf  $f(x, y)$ , then

$$\begin{aligned} E[X + Y] &= \int_{-\infty}^{\infty} \int_{-\infty}^{\infty} (x + y)f(x, y) dx dy \\ &= \int_{-\infty}^{\infty} \int_{-\infty}^{\infty} xf(x, y) dx dy + \int_{-\infty}^{\infty} \int_{-\infty}^{\infty} yf(x, y) dx dy \\ &= \int_{-\infty}^{\infty} x \left( \int_{-\infty}^{\infty} f(x, y) dy \right) dx + \int_{-\infty}^{\infty} y \left( \int_{-\infty}^{\infty} f(x, y) dx \right) dy \\ &= \int_{-\infty}^{\infty} xf_X(x) dx + \int_{-\infty}^{\infty} yf_Y(y) dy \\ &= E[X] + E[Y] \end{aligned}$$

End of Proof ■

### 5-2-3 Variance of sum and difference of 2 random variables

If  $X_1$  and  $X_2$  are 2 random variables with variances  $\sigma_1^2$  &  $\sigma_2^2$  and coefficient correlation  $\rho$  then for  $Y = X_1 + X_2$ :

$$\sigma_Y^2 = \sigma_1^2 + \sigma_2^2 + 2cov(X_1X_2) = \sigma_1^2 + \sigma_2^2 + 2\rho\sigma_1\sigma_2 \quad (5-5)$$

and for  $Y = X_1 - X_2$ :

$$\mu_Y = \mu_1 - \mu_2 \quad (5-6-1)$$

$$\sigma_Y^2 = \sigma_1^2 + \sigma_2^2 - 2cov(X_1X_2) = \sigma_1^2 + \sigma_2^2 - 2\rho\sigma_1\sigma_2. \quad (5-6-2)$$



### 5-2-3-1 Variance of sum of 2 independent random variables

If  $X_1$  and  $X_2$  are 2 independent random variables with variances  $\sigma_1^2$  &  $\sigma_2^2$  then for  $Y = X_1 + X_2$ :

$$\sigma_Y^2 = \sigma_1^2 + \sigma_2^2 . \quad (5-7)$$

### 5-2-4 Approximating mean and variance of a function of a random variable

Suppose  $X$  is a random variable with mean  $\mu_X$  and variance  $\sigma_X^2$ . Let  $Y$  be a function of  $X$ , then (K&L p101):

$$E(Y) = E[G(X)] \cong G(\mu_X) + \frac{\sigma_X^2}{2} G''(\mu_X) , \quad (5-8)$$

and also(K&L p102):

$$Var(Y) \cong [G'(\mu_X)]^2 \sigma_X^2 . \quad (5-9)$$

### Example 5.3(K&L page102)

The radius of a rod of a bar is a random variable with mean  $\mu_R = 2 \text{ mm}$  & standard deviation  $\sigma_R = \frac{1}{10} \text{ mm}$ . Find the values of the mean and the standard deviation of the bar cross section.

### Solution

The cross section of the is calculated from:  
 $A = G(R) = \pi R^2 \quad G'(R) = 2\pi R \quad G''(R) = 2\pi$

From Eq. 5-8:

$$E(A) \cong G(\mu_R) + \frac{\sigma_R^2}{2} G''(\mu_R) = \pi(2^2) + \frac{(0.1)^2}{2} (2\pi) = 4.01\pi$$

From Eq. 5-9:

$$Var(A) \cong [G'(\mu_R)]^2 \sigma_R^2 \Rightarrow Var(A) \cong (2\pi \times 2 \times 0.1)^2 = 0.16\pi^2$$

End of Example ▲

**5-2-5 Approximating the mean of a function of some independent random variables**

If  $X_1, \dots, X_n$  are independent random variables with means  $\mu_n, \dots, \mu_1$  and variances  $var(X_1), \dots, var(X_n)$ , an approximation of the mean of a function of these variables  $Y = f(X_1, \dots, X_n)$  is given by(K&L page 103):

$$E(Y) \cong f(\mu_1, \dots, \mu_n) + \frac{1}{2} \sum_{i=1}^n \frac{\partial^2 f}{\partial X_i^2} \Big|_{x=\mu} var(X_i) \quad (5-10-1)$$

Or in vector form:

$$E(Y) \cong f(\mu_1, \dots, \mu_n) + \frac{1}{2} (var(X_1) \dots var(X_n)) \begin{pmatrix} \frac{\partial^2 f}{\partial X_1^2} \Big|_{x=\mu} \\ \vdots \\ \frac{\partial^2 f}{\partial X_n^2} \Big|_{x=\mu} \end{pmatrix} \quad (5-10-2)$$

by  $x = \mu$  it is meant to replace  $X_i$  's with  $\mu_i$  's.

**5-2-6 Approximating the variance of a function of some independent random variables**

Let  $Y = f(X_1, \dots, X_n)$  be a function of independent variables  $X_1, \dots, X_n$  having standard deviations  $\sigma_{X_1}, \dots, \sigma_{X_n}$  then:

$$Va(Y) \cong \sum_{i=1}^n \left\{ \sigma_{X_i} \times \frac{\partial f(x_1, \dots, x_n)}{\partial X_i} \Big|_{\substack{X_1=\mu_1 \\ X_2=\mu_2 \\ \vdots \\ X_n=\mu_n}} \right\}^2 \quad (5-11)$$

**Example 5.4**(K&L page104)

The load  $f$  acting on a bar in tension has a mean value  $\mu_P = 10,000$  N and a standard deviation  $\sigma_P = 1,000$  N. The mean value of the cross-section area  $A$  is  $\mu_A = 5.0$  cm<sup>2</sup>, and the standard deviation of  $A$  is  $\sigma_A = 0.4$  cm. Find the mean and standard deviation of the tensile stress  $S$  on the bar.

### Solution

$$S = \frac{P}{A} = f(P, A),$$

According to Eq. 5-10-2:

$$E(S) \cong f(\mu_P, \mu_A) + \frac{1}{2} \begin{pmatrix} \sigma_P^2 & \sigma_A^2 \end{pmatrix} \begin{pmatrix} \frac{\partial^2 f}{\partial P^2} \Big|_{\substack{P=\mu_P \\ A=\mu_A}} \\ \frac{\partial^2 f}{\partial A^2} \Big|_{\substack{P=\mu_P \\ A=\mu_A}} \end{pmatrix}$$

$$\frac{\partial f}{\partial A} = -\frac{P}{A^2}, \quad \frac{\partial^2 f}{\partial A^2} = \frac{2P}{A^3}, \quad \frac{\partial^2 f}{\partial A^2} \Big|_{\substack{P=\mu_P=10000 \\ A=\mu_A=5}} = \frac{20000}{5^3} = 160$$

$$\frac{\partial f}{\partial P} = \frac{1}{A}, \quad \frac{\partial^2 f}{\partial P^2} = 0, \quad f(\mu_P, \mu_A) = \frac{10000}{5} \Rightarrow$$

$$E(S) \cong \frac{10000}{5} + \frac{1 \begin{pmatrix} 0.4^2 & 0 \end{pmatrix} \begin{pmatrix} 0 \\ 160 \end{pmatrix}}{2} \Rightarrow$$

$$E(S) \cong 2000 \text{ N/cm}^2 = 20000 \text{ KPa} = 20 \text{ MPa}$$

According to Eq. 5-11:

$$\begin{aligned} \text{Var}(S) &\cong \left[ \left( \frac{\partial f}{\partial P} \Big|_{\mu_P, \mu_A} \right) \sigma_P \right]^2 + \left[ \left( \frac{\partial f}{\partial A} \Big|_{\mu_P, \mu_A} \right) \sigma_A \right]^2 \\ &= \left[ \left( \frac{1}{5} \right) (1000) \right]^2 + \left[ \left( \frac{-10000}{5^2} \right) (0.4) \right]^2 \end{aligned}$$

$$\Rightarrow \text{Var}(S) \cong 65600 \quad \Rightarrow \quad \sigma_s \cong 256.1 \text{ N/cm}^2 = 2561 \text{ KPa}$$

Therefore a stress with mean 20 MPa and standard deviation 2.56 MPa is acting on the bar.

End of Example ▲

### 5-2-7 Approximating the mean and variance of $\frac{X}{Y}$

Let X and Y be 2 independent random variables with mean  $\mu_X$  ,  $\mu_Y$  and variance  $\sigma_X^2$  and  $\sigma_Y^2$ . The mean of the quotient is approximately :

$$E\left(\frac{X}{Y}\right) \cong \frac{\mu_X}{\mu_Y} \left[ 1 + \left( \frac{\sigma_Y}{\mu_Y} \right)^2 \right] \quad (5-12-1)$$

From Eq. 5-12-1 it is concluded that:

$$E\left(\frac{1}{Y}\right) \cong \frac{1}{\mu_Y} \left[ 1 + \left( \frac{\sigma_Y}{\mu_Y} \right)^2 \right] \quad (5-12-2)$$

Furthermore the variance of  $\frac{X}{Y}$  is approximated by:

$$\text{Var}\left(\frac{X}{Y}\right) \cong \left( \frac{\mu_X}{\mu_Y} \right)^2 \left[ \left( \frac{\sigma_X}{\mu_X} \right)^2 + \left( \frac{\sigma_Y}{\mu_Y} \right)^2 - \left( \frac{\sigma_Y}{\mu_Y} \right)^4 \right] \quad (5-12-3)$$

### Example 5.5

Repeat Example 5.4 using Eqs. 5-12-1 & 5-12-3.

### Solution

$$E(S) = E\left(\frac{P}{A}\right) \cong \frac{\mu_P}{\mu_A} \left[ 1 + \left(\frac{\sigma_A}{\mu_A}\right)^2 \right] = \left(\frac{10000}{5}\right) * \left(1 + \left(\frac{0.4}{5}\right)^2\right) = 2012.8 \text{ N/cm}^2$$

$$\Rightarrow E(S) = 20128 \text{ KPa}$$

$$\text{Var}(S) = \text{Var}\left(\frac{P}{A}\right) \cong \left(\frac{\mu_P}{\mu_A}\right)^2 \left[ \left(\frac{\sigma_P}{\mu_P}\right)^2 + \left(\frac{\sigma_A}{\mu_A}\right)^2 - \left(\frac{\sigma_A}{\mu_A}\right)^4 \right]$$

$$= \left(\frac{10000}{5}\right)^2 * \left[ \left(\frac{1000}{10000}\right)^2 + \left(\frac{0.4}{5}\right)^2 - \left(\frac{0.4}{5}\right)^4 \right] = 65436$$

$$\sigma_S \cong 255.8 \text{ N/cm}^2 = 2558 \text{ KPa.} \quad \text{End of Example} \blacktriangle$$

## 5.3 Statistical Tolerance

Since it is impossible to make everything to an exact size, the specification for design dimensions and variables is usually given as a nominal value plus minus a number. For example in  $2.500 \pm 0.003$ , 2.500 is the nominal value and  $\pm 0.003$  is the tolerance. Tolerance is the total amount a dimension may vary

and is the difference between the upper and lower (minimum) limits of the specification.

It is worth mentioning that tolerance is sometimes written as a percent; e.g.  $2.500 \pm 0.12\%$ . By this notation it is meant that tolerance is  $\pm \frac{0.12}{100} \times 2.500 = \pm 0.003$ .

Next, after reminding the calculation of tolerance of linearly and nonlinearly assembled parts, an example shows the calculation of reliability when tolerance is given. Though the chapter it is assumed that the tolerance of a component or assembly is  $\pm k\sigma$  where  $\sigma$  is the standard deviation of the component or the assembly.  $k$  is a constant which is usually equal 3.

### 5-3-1 Relationship of assembly tolerance parts tolerance

Consider a product composed of  $n$  similar parts. Let the dimension of each part be denoted by  $X_i, i = 1, \dots, n$  with mean and variance  $\mu_{part}$  and  $\sigma_{part}^2$ . The dimension of the assembled product is therefore  $X = X_1 + \dots + X_n$ . The mean and variance of  $X$  denoted by  $\mu_{sum}$  and  $\sigma_{sum}^2$  equals:

$$\mu_{sum} = n\mu_{part} \quad (5-13-1)$$

$$\sigma_{sum}^2 = n\sigma_{part}^2 \quad (5-13-2)$$

$$\sigma_{part} = \sqrt{\frac{\sigma_{sum}^2}{n}} \quad (5-13-3)$$

Let us denote the specification of each part by  $a \pm t$  and that of the assembled part by  $b \pm \Delta$  and tolerance limits by U and L. Assuming  $\frac{(U-L)_{part}}{2} = k\sigma_{part}$ ,  $\frac{(U-L)_{sum}}{2} = k\sigma_{sum}$  i.e. the tolerance equals  $k \times$  standard deviation, then substituting  $\sigma_{sum} = \frac{(U-L)_{sum}}{2k}$  and  $\sigma_{part} = \frac{(U-L)_{part}}{2k}$  in Eq. 5-13-3 results in:

$$(U - L)_{part} = \sqrt{\frac{(U - L)_{sum}^2}{n}} \quad (5-14)$$

Let  $\Delta = \frac{(U-L)_{sum}}{2}$  and  $t = \frac{(U-L)_{part}}{2}$  then:

$$t = \frac{\Delta}{\sqrt{n}} \quad (5-15-1)$$

$$\Delta = t\sqrt{n} \quad (5-15-2)$$

Then the tolerance specification of a product assembled from  $n$  similar parts with specification  $a \pm t$  would be  $n \times a \pm \Delta$ . If the  $n$  parts have different specifications  $a_1 \pm t_1 \dots a_i \pm t_i \dots a_n \pm t_n$  then if  $\frac{(U-L)_i}{2} = k\sigma_i$ , the specification of the assembled part would be  $\sum_{i=1}^n a_i \pm \Delta'$  where:

$$\Delta' = \sqrt{\sum_{i=1}^n t_i^2} \quad (5 - 16)$$

### Example 5-6

Suppose 10 similar parts with specification  $2.000 \pm 0.012$  are assembled in a series configuration. What is the specification of the assembled product?

### Solution

The specification of the assembled part is  $10 \times 2.000 \pm \Delta$  where  $\Delta = t\sqrt{n} = 0.012\sqrt{10} = 0.0379$  or:  $20.000 \pm 0.0379$ .  
End of Example▲

### Example 5-7

We would like to produce a product with specification  $20.000 \pm 0.0379$  as an assembly of 10 similar parts. What should be the tolerance of each part?

### Solution

The specification of each of the 10 parts must be  $\frac{20.000}{10} \pm t$  where  $t = \frac{\Delta}{\sqrt{n}} = \frac{0.0379}{\sqrt{10}} = 0.012$ . End of Example▲

### Example 5-8



A part with specification  $2.000 \pm 0.012$  is assembled with another part have the specification of  $3.000 \pm 0.016$ . What is the specification of the assembly?

### Solution

The specification of the assembled part is  $2.000+3.000\pm\Delta'$  where  $\Delta'$  is given by Eq. 5-16 as follows:

$\Delta' = \sqrt{\sum_{i=1}^n t_i^2} = \sqrt{(0.012)^2 + (0.015)^2} = 0.020$ . Therefore the specification is:  $3.000\pm 0.020$  End of Example▲

### 5-3-2 Tolerance in complex systems

In the previous section, tolerances for series configurations were considered. In this section an example illustrates how to calculate the tolerance of an assembly in which a nonlinear function of the components exists. This is usually accomplished by linearization of the function by Taylor's expansion up to the first order around the nominal dimensions.

**Example 5-9** (Extracted from Bowker-Lieberman, 1972 p94)

In the electrical circuit shown below, find the tolerance of the output voltage  $E_0 = E_1 NK$ . The components have the following specifications:

	Distribution	nominal Value	$\pm$	
$E_1$	normal	$E_1^* = 40$	0.5	$40 \pm 0.5$
$N$	normal	$N^* = \frac{1}{2}$	1%	$\frac{1}{2} \pm 0.01 \times \frac{1}{2}$
$K$	normal	$K^* = 3$	2%	$3 \pm 0.02 \times 3$

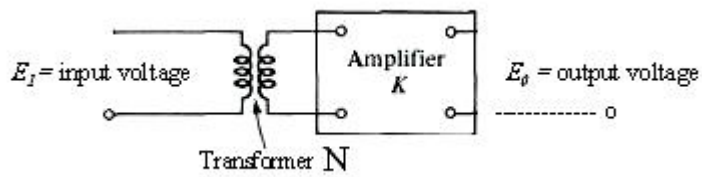

The mean of the distributions are equal to their nominal values.

**Solution**

Taylor series of a 3-variable function up to the first order is as follows:

$$f(x,y,z) = f(a,b,c) + \frac{1}{1!} \left[ (x-a) \frac{\partial}{\partial x} + (y-b) \frac{\partial}{\partial y} + (z-c) \frac{\partial}{\partial z} \right] f(x,y,z) \Big|_{x=a,y=b,z=c} + \dots$$

(5-17)

For the linearization of  $E_0 = E_1NK$ ,  $E_0$  is expanded into a Taylor series around the nominal values  $E_1^*, N^*, K^*$  with help of the above relationship as follows:

$$E_0 \cong E_1^* N^* K^* + \frac{1}{1!} \left[ (E_1 - E_1^*) N^* K^* + (N - N^*) E_1^* K^* + (K - K^*) E_1^* N^* \right] \Rightarrow$$

$$E_0 \cong N^* K^* E_1 + E_1^* K^* N + E_1^* N^* K - 2E_1^* N^* K^*$$

This approximation is a linear combination of  $E_0, N, K$ . Since random variables  $E_1, N, K$  have the means  $E_1^*, N^*, K^*$ , therefore the distribution of  $E_0$  has the mean  $\mu_{E_0}$  calculated from:

$$\mu_{E_0} = E \left( N^* K^* E_1 + E_1^* K^* N + E_1^* N^* K - 2N^* E_1^* K^* \right)$$

Since the mean of the distributions of  $E_1, N, K$  equal  $E_1^*, N^*, K^*$  therefore the mean of  $E_0$  is:

$$\mu_{E_0} = N^* K^* \mu_{E_1} + E_1^* K^* \mu_N + E_1^* K^* N^* - 2N^* K^* E_1^*$$

$$\text{Or } \mu_{E_0} = E_1^* \times N^* \times K^*$$

The variance of  $E_0$ , denoted by  $\sigma_{E_0}^2$ , is calculated from the linear approximation of independent variables  $E_1, N, K$  i.e:

$$E_0 \cong N^* K^* E_1 + E_1^* K^* N + E_1^* N^* K - 2N^* E_1^* K^* \Rightarrow$$

$$\sigma_{E_0}^2 \cong \left( N^* K^* \right)^2 \sigma_{E_1}^2 + \left( E_1^* K^* \right)^2 \sigma_N^2 + \left( E_1^* N^* \right)^2 \sigma_K^2 \quad (5-18)$$

No notice that under the following 3 assumptions

a) During production, the dimension of each component can be centered at its nominal values i.e. the magnitude of the variance of each component is such that the natural tolerance limits *coincides* with the specifications limits  $a \pm b$ ,

b) The distributions are normally distributed with means equal to nominal values

c) For each component all but  $100\alpha\%$  of the values will fall within the corresponding  $a \pm b$  the largest value of the standard deviation of the dimension denoted by  $\sigma_{\text{allowed}}$  is given by (see K&L pages 93-96):

$$\sigma_{\text{allowed}} = \frac{b}{Z_{\frac{\alpha}{2}}} \quad (5-19)$$

where  $Z$  is the critical value related to normal distribution given in Table D or by a software such as MATLAB; e.g. for  $\alpha=0.27\% \Rightarrow Z_{\frac{\alpha}{2}} = Z_{0.00135} = \text{norminv}(1-0.00135) = 3$  and

therefore:

$$\sigma_{E_1} = \frac{0.5}{3}, \quad \sigma_N = \frac{\frac{1}{2} \times 0.01}{3} = 0.0017, \quad \sigma_k = \frac{3 \times 0.02}{3} = 0.02$$

Substituting numerical values in the right hand side of Eq. 5-18 gives  $\sigma_{E_o} = 0.512$ .  $E_o = E_1^* N^* K^* = 40 \times \frac{1}{2} \times 3 = 60$  is the nominal value of the output voltage. To write the specification of output voltage  $E_o$  as  $60 \pm \Delta$  note that the distribution of  $E_o$  can be approximated by a normal with mean equal to the nominal value (60); therefore for  $\alpha = 0.27\%$  from Eq. 5-19 :

$$0.512 = \frac{\Delta}{\frac{z_{\alpha}}{2}} = \frac{\Delta}{\frac{z_{0.0027}}{2}} = \frac{\Delta}{z_{0.00135}} = \frac{\Delta}{3} \Rightarrow \Delta = 1.536$$

$$E_0 : 60 \pm 1.536 \quad \text{or since } \frac{1.536}{60} = 2.56\% \Rightarrow E_0 : 60 \pm 2.56\%$$

Therefore the output voltage  $E_0$  is 60 volts  $\pm 2.56\%$ .  $\blacktriangle$

The following example shows how tolerance affects reliability.

**Example 5-10** (Based on K&L page 165)

A circular bar is subjected to a tension load  $S$ , shown below.

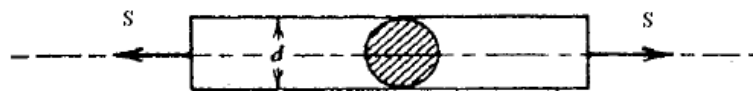

Due to the nature of manufacturing, the diameter  $d$  of the bar is a random variable and due to various raw materials used the ultimate tensile strength of the rod is also a random variable with mean  $\mu_s = 10000$  psi and standard deviation 5000psi.

The random variable  $S$  has  $\mu_s = 4000$  lb and  $\sigma_s = 100$  lb. If the load and strength are normally distributed, the following

equation<sup>1</sup> is used to calculate the reliability of these kind of bars:

$$R = \Pr(S < \delta) = \Phi_Z(z) \quad (5-20)$$

where

$$z = \frac{\mu_\delta - \frac{\mu_S}{\pi\mu_r^2}}{\sqrt{\sigma_\delta^2 + \frac{\sigma_S^2 + \frac{4(0.01p)^2}{9}\mu_S^2}{\pi^2\mu_r^4}}} \quad \text{and}$$

$\Phi_Z(z)$  is the CDF of normal standard distribution.

The diameter of the bar has a mean of  $\mu_r = 0.12635$  inches and its specification is  $\mu_r \pm p\%$ . The load and the strength are normally distributed. To know how the variations in the rod diameter affect the rod reliability, conduct a sensitivity analysis of the rod reliability with respect to the rod radius.

### Solution

The following table shows the reliability of the rod computed using MATLAB from Eq. 5-20 for seven values of  $p$  in  $\mu_r \pm p\%$  and  $\mu_\delta = 100 \times 10^3 \text{ psi}$ ,  $\sigma_\delta = 5 \times 10^3 \text{ psi}$ ,  $\mu_S = 4 \times 10^3 \text{ lb}$ ,  $\sigma_S = 100 \text{ lb}$ ,  $\mu_r = 0.12635$ .

---

<sup>1</sup> For proof see K&L page 165

$p$	$z$	$R = \Phi_z(z) = \text{normcdf}(z)$
0	3.760	0.999915
0.5	3.756	0.999914
1.0	3.74	0.999908
1.5	3.72	0.999900
3.0	3.61	0.999847
5.0	3.37	0.999624
7.0	3.10	0.999032

If for example the specification of the radius of the rod is  $0/12635 \pm 1.5\%$  i.e.  $p=1.5$ ,  $z$  turns to be  $z=3.72$  and the rod reliability would be 99.99% as calculated below:

$$p=1.5;$$

$$z=(10^5-$$

$$(4000/(\pi*(0.12635)^2))/\sqrt{5000^2+((100^2+((4*(0.01*p)^2)/9)*4000^2))}/(\pi^2*0.12635^4))$$

$$R= \text{normcdf}(z)$$

End of Example. ▲

## Exercises<sup>1</sup>

In the following problems assume all dimensions are normally distributed and the tolerance range is  $6\sigma$  ( $\pm 3\sigma$ )

1. The parts of a contact assembly for a relay are shown in the following figure. The dimension  $x$  represents the amount of

---

<sup>1</sup> Problems 1 through 7 are from Chap. 5 page 113 problems(1,3,5,7,9,11,13)

intentional overtravel (called "wipe") of the upper contact that would occur if the upper contact was clamped to the part at left. Find the nominal dimension  $x$  and its tolerance.

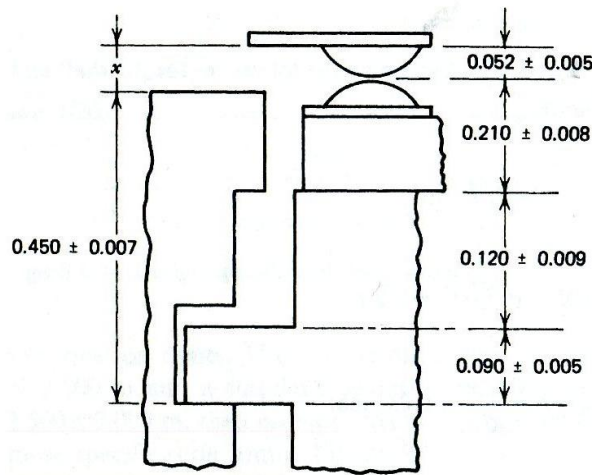

2. A partially finished connecting rod is shown in the following figure. Each radius has a tolerance of  $\pm 0.002$ . The tolerance for the distance  $L$  between the centers of the holes is  $\pm 0.004$ . Find the tolerance for the dimension  $h$ .



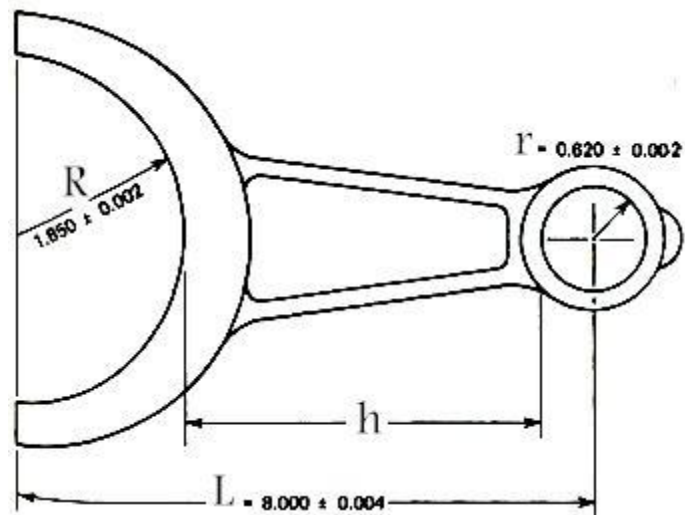

3. A rectangular solid bar has the following dimensions:

$X : 2 \pm 0.002m$  ,  $Y : 1 \pm 0.001m$  ,  $Z : 4 \pm 0.008m$  . Find the specification of  $V = XYZ$ .

4. The head of a screw is shown in the following figure. The various dimensions are formed in such a manner that there is no association between them; that is, they are mutually independent. Determine the tolerance for  $H$ , the depth of the screw head. The dimensions  $\theta$ ,  $D$ , and  $d$  and their tolerances are:

$$\theta : 90^\circ \pm 2' \quad D = 0.800 \pm 0.002 \text{ in} \quad d = 0.400 \pm 0.001 \text{ in}$$

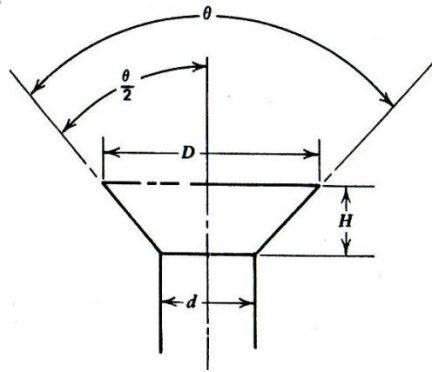

5. Let random variable  $Y = \frac{aX_1}{X_2X_3}$ , where  $a$  is a constant and the 3 variables are independent and have the following properties.

Variable	$X_1$	$X_2$	$X_3$
mean	4	2	1
stand. devia	0.4	0.2	0.1

Approximate the expected value and standard deviation of  $Y$ .

6. An automotive component is subjected to a fluctuating stress with mean and the amplitude  $S_{mean} = \frac{S_{max}+S_{min}}{2}$ ,  $S_{amp} = \frac{S_{max}-S_{min}}{2}$ , as shown in the following figure. The maximum value of the stress ( $S_{max}$ ) is a normally distributed random variable with mean= 600 kPa and standard deviation=40kPa. The minimum value of the stress( $S_{min}$ ) is a gamma distributed random variable with parameters  $n= 17$  and  $\frac{1}{\lambda} = 20kPa$ .

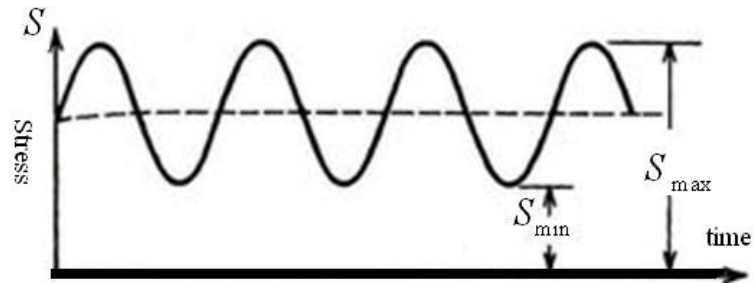

Determine the value which the random variable  $s_{mean}$  will exceed only 1.3% of the time. Also determine the value which the random variable  $s_{amp}$  will not exceed 90% of the time.

**Hint:** For largish  $n$  a gamma distribution  $(n, \lambda)$  could be approximated with a normal distribution  $(\mu = \frac{n}{\lambda}, \sigma = \frac{\sqrt{n}}{\lambda})$ ; because it be considered the sum of  $n$  inependent exponential distribution with parameter  $(\lambda)$ ,

7. The analysis of the loading of a component revealed a load diagram as shown in the Following figure..

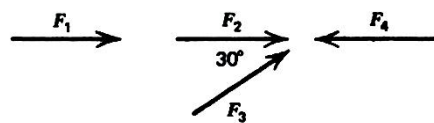

The four forces  $F_1, F_2, F_3,$  and  $F_4$  are random variables, the distributions of which are given in the following table

Force	Distribution	Parameters
$F_1$	Exponen.	$\frac{1}{\lambda} = 2.6kN$
$F_2$	Normal	$\mu = 41.6kN, \sigma = 11.03kN$
$F_3$	Normal	$\mu = 37.5kN, \sigma = 3.9kN$
$F_4$	Normal	$\mu = 39kN, \sigma = 10.07kN$

Calculate the mean and the variance of the magnitude of the horizontal resultant load.

Hint: The gamma distribution  $(n, \lambda)$  may be approximated by a normal distribution with  $\mu = \frac{n}{\lambda}$  and  $\sigma = \frac{\sqrt{n}}{\lambda}$ .

8.(Example5-6 page 104K&L)

An electrical circuit has two resistances  $R_1, R_2$  in parallel as shown below. The value of each resistance is a random variable. We know that

$$\mu_{R_1} = 100\Omega, \sigma_{R_1} = 10\Omega, \mu_{R_2} = 200\Omega, \sigma_{R_2} = 15\Omega,$$

Determine the mean and standard deviation of  $R_T$ .

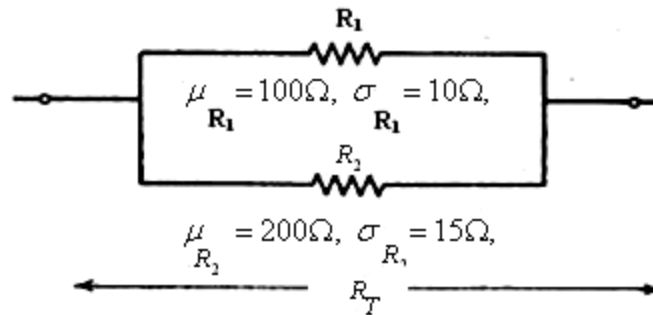

Answer is given in K&L page 105.

9. A kind of beam has a rectangular-shaped cross-section. The dimensions of the cross-section, denoted by  $a$  &  $b$ , are random variables with mean  $\mu_a = 20$  mm,  $\mu_b = 60$  mm and standard deviation  $\sigma_a = 0.02$  mm,  $\sigma_b = 0.1$  mm. A stress is applied to the beam. The bending stress is a random variable with mean 2000Nm and standard deviation 10Nm. Find an approximate value for the maximum bending stress(S). The dimensions are assumed independent.

Anyone pursuing his goals honestly  
does not slip up  
and if he does, he can seek a way out

# Chapter 6

## Estimation of Mean Life & Reliability, Related Experiments & Tests

# 6

## **Estimation of Mean Lifetime & Reliability and Related Experiments & Tests**

### **Aims of the chapter**

This chapter deals with the estimation of 2 statistical measures related to a product i.e. reliability and expected value of products lifetime. Some standard experiments and statistical tests of hypothesis are also mentioned, and some acceptance sampling plans based on the lifetime are introduced. The emphasis is on the products whose lifetimes are exponentially distributed.

### **6.1 Introduction**

The problem of estimation of the lifetime and the reliability of products is a common problem in the control of products quality. When we have the lifetimes of a random sample of the product, one obvious way to estimate the mean lifetime is calculating the sample mean. Another way is performing special life tests on the sample and then calculating the mean. A third way of life testing is called accelerated life testing which involves the acceleration of failures to quantify the life

characteristics of the product at normal use conditions; in other words it involves capturing product life data under accelerated stress. These 3 ways are pointed out in this chapter. The present chapter also mentions some statistical tests hypothesis and some acceptance sampling plans related to lifetime.

## 6.2 Estimation of product mean life given a lifetime sample of size $n$

Suppose a random sample is taken from a product and the products in the sample are tested until all of them fail and the lifetimes  $x_1 \dots x_n$  is obtained. The following equation gives an unbiased estimate for the mean lifetime ( $\theta$ ) of the product:

$$\hat{\theta} = \frac{\sum x_i}{n} = \bar{X} \quad (6-1)$$

This equation could be used for any product with any lifetime distribution.

## 6.3 Tests for Estimating Mean Life

Consider a life testing where  $n$  items are simultaneously placed on test. The purpose of the life tests here is to calculate a point estimate and sometimes interval estimates for the product mean life. It often occurs that we need to discontinue the life test before all the elements in the sample fail. In such cases, we say that the test has been “suspended,” “censored,” or “truncated” .Censoring schemes employed during the life test make the inspection as a cost effective one. Time censoring (Type I), failure censoring (Type II) are 2 common types of the censoring



schemes employed in life tests. Each of these 2 types might be performed in 2 ways:

**i)Censoring schemes with replacement.**

Replacement during a life testing means that once observing a failure item, it is replaced by a new or repaired one. In other words, the total number of inspected items during the test remains constant  $n$ .

**ii)Censoring schemes without replacement**

**6.3.1 Time censoring (Type-I)**

In a time censoring scheme,  $n$  items are simultaneously placed on the test and the test terminates at some specified time.

**6.3.2 Failure censoring (Type-II)**

In a failure censoring scheme,  $n$  items are simultaneously placed on the test and the test continues until particular number of failures, say  $r$ , occurs.

To summarize the above discussion: it often occurs that we need to truncate our life test before all the elements in the sample experience the failure. Two common types of truncation or censoring are :

$$Censoring \left\{ \begin{array}{l} \text{Type I: Time censoring} \left\{ \begin{array}{l} \text{with Replacement} \\ \text{without Replacement} \end{array} \right. \\ \text{Type II: Failure censoring} \left\{ \begin{array}{l} \text{with Replacement} \\ \text{without Replacement} \end{array} \right. \end{array} \right.$$

## 6.4 Estimation of mean life

### List of Symbols

$n$	Number of units of product placed on life test
$r$	Number of failures
$t^*$	Predetermined amount of time for a life test
$T$	The total operation time of all test items
$x_i$	Time to failure for product no. $i$
$x_{(i)}$	Time to failure for $i^{\text{th}}$ failure
$x_{(r)}$	Time to failure for failure no. $r$
$\theta$	Mean lifetime of the product
$\hat{\theta}$	Estimate of $\theta$

The mean life ( $\theta$ ) or MTBF of products is estimated from the following general formula:

$$\hat{\theta} = \frac{T}{r} \quad (6-2)$$

where

$T$  = the total operation time of all items placed on test including those failed,

$r$  = total number of failures occurred during the life test

Needless to say if the lifetime of a product is exponentially distributed with pdf  $f(x) = \frac{1}{\theta} e^{-\frac{x}{\theta}}$ , Eq. 6.2 estimates the parameter of this diminution.

Note that;

To verify "that an exponential distribution fits the life data" a test of hypothesis such as Bartlett's test (see K&L page 239) or Q-Q plot with following MATLAB command could be used:

```
X=[...data]; pd=makedist('exponential', mean(X));qqplot(X,pd).
```

### **Example 6-1**(K&L page 251)

A truck was shaken on a simulator for a total time of 245 hours. During this life test 20 failures occurred. The time between failures can be well approximated by an exponential distribution(see page 240 K&L). Estimate the mean life parameter.

### **Solution**

$$MTBF = \hat{\theta} = \frac{245}{20} = 12.25 \text{ hr} \text{ End of Example} \blacktriangle$$

$$\text{Calculation of T for } \widehat{MTTF} = \widehat{MTBF} = \hat{\theta} = \frac{T}{r}$$

To calculate T for estimating , let us distinguish the following cases for discontinuing our tests:

-Type I tests(time truncation) with replacement

- Type I tests (time truncation) without replacement

- Type II tests (failure truncation) with replacement

- Type II tests (failure truncation) without replacement

### 6-4-1 Type I censoring life test

In type-I censoring at a predetermined time, say  $t^*$ , the life test is terminated. The test could be performed without or with replacement.

#### 6-4-1-1 Type I censoring life test with replacement

In time-truncated tests with replacement, in fact all  $n$  items work until the predetermined time  $t^*$  and the total operation time ( $T$ ) of all items placed on test including those failed is:  $T = n \times t^*$ ; therefore:

$$\hat{\theta} = \frac{T}{r} = \frac{nt^*}{r} \quad (6-3)$$

Where  $r \geq 1$  is the number of failures during the test time  $t^*$ .

An application of this equation is, for example, when we have where we have  $n$  test stands, and we cycle each test stand for  $\tau$  cycles. As items fail they are replaced. Where a truncation time is specified this is called Type I censoring. Here we have (K&L page 252)

$$\hat{\theta} = \frac{n\tau}{r} \quad (6-4)$$

**Example 6-2**(Example 10-12 K&L page 252 based on Example 10-3 page 241)

Nine stands are used for testing the life of a kind of switch. As items fail they are replaced. Each stand was cycled 20,000 times, and a counter recorded the cycle number at which failures occurred. The following table contains the data. Estimate MTBF.

Stand no.	1	2	3	4	5	6	7	8	9
Cycles at which failure occurred	6700	4600	4100, 18100, 18950	5400	3100, 8100	2600	No failure	4700	No failure

Counters were not reset when a new switch was placed on test. Thus counts are continuous from zero. Total test is 20,000 cycles per stand with replacement.

**Solution**

$$T = n\tau = 9 \times 20000 = 180000 \text{ cycles}$$

Ten failures occurred during the test duration i.e.  $r=10$ , therefore :

$$MTBF = \hat{\theta} = \hat{\theta} = \frac{T}{r} = \frac{180000}{10} = 18000$$

This means that on the average, each switch could be cycled 20,000 times before failure. ▲

**Example 6-3**(Lewis,1994 page240)

A chemical plant has 24 process control circuits. During 5000 hr of plant operation. The circuits experience 14 failures. After each failure the unit is immediately replaced. What is the MTTF for the control circuits?

**Solution**

$$T = 24 \times 5000 = 120,000 \text{ hr}$$

$$MTTF = \hat{\theta} = \frac{T}{r} = \frac{nt^*}{r} = \frac{120000}{14} = 8571 \text{ hr. End of Example} \blacktriangle$$

**6-4-1-2 Type I censoring life test without replacement**

In type I censoring the test is terminated at some predetermined time; in nonreplacement case the number of failures  $1 \leq r \leq n$  and MTTF is estimated from (Lewis, 1994 page 239, Mann, 1974 page 173):

$$\hat{\theta} = \frac{T}{r} = \frac{(n-r)t^* + \sum_{i=1}^r x_{(i)}}{r} \tag{6-5}$$

where

- $r$  number of items failed
- $T$  total operational time for the  $n$  units tested
- $t^*$  duration of life test
- $n$  number of items placed on life test
- $x_{(i)}$  time of the  $i^{\text{th}}$  failure  $x_{(1)} < x_{(2)} < \dots < x_{(i)} < \dots$

#### Example 6-4:

20 units of a kind of gyroscope were placed on a 30-day life test without replacement. 9 units failed at the following times (in days) 14.4, 5.1, 27.7, 29.1, 23.6, 20.00, 10.5, 13.5, 27.4. Estimate MTTF .

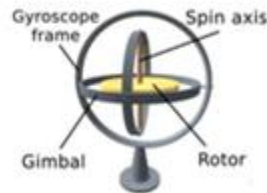

#### Solution

$$x_1 = 14.4, \dots, x_9 = 27.4 \quad \sum x_i = 171.3$$

$$t^* = 30 \text{ days}, T = (n - r)t^* + \sum_{i=1}^r x_i \quad T = (20 - 9) \times 30 + 171.3 = 501.3$$

$$MTTF = \hat{\theta} = \frac{T}{r} = \frac{501.3}{9} = 55.7 \text{ days} \text{ .End of Example} \blacktriangle$$

**6-4-2 Type -II censoring life test**

In Type II or failure censoring, the test is discontinued after occurring a predetermined number of failures (  $r$  ). This type might be performed with or without replacement.

*6-4-2-1 Type II censoring life test without replacement*

In this kind of experiment  $n$  units of a product are placed simultaneously on life test and failed units are not replaced. When the number of the failure reaches the predetermined number  $r$  ( $1 \leq r \leq n$ ), the test is terminated. The estimate for MTTF is (K&L page252, Lewis,1994 page239):

$$\hat{\theta} = \frac{T}{r} = \frac{(n-r)x_{(r)} + \sum_{i=1}^r x_i}{r} \tag{6-6}$$

$x_i$   $i^{\text{th}}$  value in the sample containing failure times

$x_{(r)}$  The time of the  $r^{\text{th}}$  failure

$T$  Total operation time of all items placed on life test

$\sum_{i=1}^r x_i = \sum_{i=1}^r x_{(i)}$  Total operation time of failed items

$(n - r)x_{(r)}$  operation time of the functional items at the end of the test

References such as Mann(1974) page 164 provide some descriptions on the proof of Eq. 6.6 .

It is obvious that:



1. If the time of the life test is such that all  $n$  items fail then  $r=n$  and Eq. 6.1 i.e.  $\hat{\theta} = \frac{\sum_{i=1}^n x_i}{n}$  is obtained.
2. If  $x_{(r)}$  coincides the test time  $t^*$  the equations of Sec 6-4-1-2 & 6-4-2-1 give the same result.

### Example 6-5

The director of a laboratory, place 20 units of a kind of gyroscope on life test and decides to stop the test whenever the tenth failure occurs. At time 41.2 the tenth failure occurs and the experiment terminates. The time of the other failures are:

14.4, 5.1, 27.7, 29.1, 23.6, 20.0, 10.5, 13.5, 14.4. Find the MTTF of the gyroscope.

### Solution

$$T = (n-r)x_{(r)} + \sum_{i=1}^r x_i = (20-10) \times 41.2 + 27.4 + \dots + 14.4 + 41.2 = 624.5$$

Then according to Eq. 6-6

$$MTBF = \hat{\theta} = \frac{T}{r} = \frac{624.5}{10} = 62.45 \text{ days}. \text{ End of Example } \blacktriangle$$

#### 6-4-2-2 Type II censoring life test with replacement

In this kind of experiment  $n$  units of a product are placed simultaneously on life test; when a unit fails it is replaced. The test is terminated when the number of failures reaches a

predetermined number  $r$ . In other words the test terminates at time  $x_{(r)}$ . The estimate for MTTF is (Lewis, 1994 page 239):

$$\hat{\theta} = \frac{nx_{(r)}}{r} \quad (6-8)$$

$n$  The number of items placed initially on the life test

$x_{(r)}$  The time when the  $r^{\text{th}}$  failure occurs

**Description of Eq. 6-8:**

The experiment ends at time  $x_{(r)}$ ;  $r \geq 1$  and  $r$  could be less or greater than  $n$ . During the experiment time totally  $r$  failures occur for all the  $n$  units, therefore each unit on the average fails  $\frac{r}{n}$  times and the mean time to failure is  $\hat{\theta} = \frac{x_{(r)}}{\frac{r}{n}}$ . Hence we

have the following estimate for MTBF:

$$MTBF = \hat{\theta} = \frac{T}{r} = \frac{nx_{(r)}}{r} \quad (6-9)$$

**Example 6-6** (Lewis, 1994 page 241)

Six units of a new high-precision pressure monitor are placed on an industrial furnace. After each failure the monitor is immediately replaced. However, the eighth failure occurs after only 840 hours of service. It is decided that the high-temperature

environment is too severe for the instruments to function reliably, and the furnace is shut down to replace the pressure monitors with a more reliable, and expensive, design. Assuming that the failures are random, estimate the MTTF of the monitors.

### Solution

$$T = nx_{(r)} \quad n = 6 \quad r = 8 \quad x_{(r)} = 840$$

$$T = 6 \times 840 = 5040 \text{ hr} \quad \widehat{MTTF} = \hat{\theta} = \frac{T}{r} = \frac{5040}{8} = 630 \text{ hr} \blacktriangle$$

### Tests Summary

Table 6.1 summarizes the relationships related to the above life tests:

Type of Experiment	Replacement	Eq. No.	$\hat{\theta} = \frac{T}{r} = \frac{nt^*}{r}$
Time-terminated (Type-I censoring)	With Replacement	6-3	$\hat{\theta} = \frac{T}{r} = \frac{(n-r)t^* + \sum_{i=1}^r x_{(i)}}{r}$
	Without Replacement	6-5	$\hat{\theta} = \frac{(n-r)x_{(r)} + \sum_{i=1}^r x_i}{r}$
Failure-terminated (Type-II censoring)	Without Replacement	6-6	$\hat{\theta} = \frac{nx_{(r)}}{r}$
	With Replacement	6-8	$\hat{\theta} = \frac{T}{r} = \frac{nt^*}{r}$

## 6-5 On the Accelerated Life Testing(ALT)

At the end of the subject of experiments, it is worth mentioning that there are some life tests called accelerated life tests for quick obtaining of lifetime data.

Conventional way for preparing the lifetime data of a product is to place some units of it on life test under normal use conditions, until all fail. This procedure for obtaining TTFs is

difficult and sometimes impossible. Some experiment methods called Accelerated Life Tests have been developed to expedite the test and save time and cost during the design and development validation phase in many industries. ALT perform the life test at a high level of a parameter or a variable. The <sup>1</sup> results obtained at high levels of the accelerating variables are then extrapolated to provide information about the product life under normal use conditions.

In accelerated life tests, place a sample of the product on life test under elevated working conditions (temperature, voltage, pressure, rate, vibration, humidity and so on...) in order to accelerate the failure mechanisms. The results are then used to extrapolate to usual operating conditions.

Many references including Cabarbaye(2019), Tobias & Trindade (2012) discuss ALT. Softwares such as Minitab perform data analysis for ALT.

## **6-6 Confidence interval for mean lifetime- Exponential distribution case**

Whenever a sample is taken from a population, different estimate for a parameter of the population is obtained. To modify this difficulty one could construct a confidence interval for the parameter. Suppose  $X_1, \dots, X_n$  is a random sample from a

---

<sup>1</sup>Pascual et al, 2006 Accelerated Life Test Models and Data Analysis, In book: Springer Handbook of Engineering Statistics (pp.397-426)

distribution with unknown parameter  $\theta$ , the interval  $[G_1, G_2]$  where  $G_1, G_2$  are function of  $x_1, \dots, x_n$  is called a  $1-\alpha$  confidence interval (CI) for  $\theta$  if :

$$\Pr (G_1 < \theta < G_2) = 1 - \alpha \quad (6-10)$$

Next the confidence interval for the mean of exponentially distributed lifetimes. To do this consider a life test of a sample taken from exponentially-distributed-life product ,terminated after time  $T$  during which the number of failed items has reached  $r$ . assuming zero-minimum life,  $1 - \alpha$  confidence interval for the mean of an exponentially-distributed –life

product is(K&L page 253):  $\left( \frac{2T}{\chi^2_{2r, \frac{\alpha}{2}}}, \frac{2T}{\chi^2_{2r, 1-\frac{\alpha}{2}}} \right)$ .

This confidence interval (CI) which could be written as:

$$\Pr \left[ \frac{2T}{\chi^2_{2r, \frac{\alpha}{2}}} \leq \theta \leq \frac{2T}{\chi^2_{2r, 1-\frac{\alpha}{2}}} \right] = 1 - \alpha \quad (6-11)$$

Is based on the assumption the lifetime of the product is

exponentially distributed with mean  $\theta$  estimated from  $\hat{\theta} = \frac{T}{r}$ .

The proof relies on the fact that random variable  $\frac{2T}{\theta}$  has a Chi-

squared distribution with  $2r$  degrees of freedom (Appendix 10.D K&L page 281).

This CI for example, is suitable when we have  $n$  test stands where items are replaced as they fail and the test is discontinued at a predetermined time. Or when we might drive vehicles over e.g. a 40,000 km test schedule and elect to count failures rather than failure intervals (K&L page 254).

### Example 6.7

8 leaf springs were tested to failure. The results, in cycles, follow:

$X_{(1)}$	$X_{(2)}$	$X_{(3)}$	$X_{(4)}$	$X_{(5)}$	$X_{(6)}$	$X_{(7)}$	$X_{(8)}$
8712	21915	39400	54613	79000	110200	151208	204312

- a) Estimate the mean lifetime  $\theta$
- b) Suppose the lifetime is exponentially distributed, find a 95% confidence interval for  $\theta$
- c) find a 95% confidence interval for the spring reliability if vibrated 4000 cycles.

### Solution

a) The point estimate for the mean life ( $\theta$ ) is:  $\hat{\theta} = \frac{T}{r}$

$$T = (n-r)x_{(r)} + \sum_{i=1}^r x_i = (8-8)x_{(8)} + \sum_{i=1}^8 x_i \Rightarrow$$

$$T = \sum_{i=1}^8 x_i = \sum_{i=1}^8 x_{(i)} = 669320$$

$$\hat{\theta} = \frac{\sum_{i=1}^8 x_{(i)}}{8} = \bar{X} = \frac{669320}{8} = 83665$$

b) If the lifetime of the spring is exponentially distributed, the CI for  $\theta$  is given from Eq. 6-11:

$$\frac{2T}{\chi_{2r, \frac{\alpha}{2}}^2} \leq \theta \leq \frac{2T}{\chi_{2r, 1-\frac{\alpha}{2}}^2}$$

$r = n = 8$ ,  $\alpha = 5\%$ . From Table E or MATLAB:

$$\chi_{16, 0.975}^2 = \text{chi2inv}(0.025, 16) = 6.91,$$

$$\chi_{16, 0.025}^2 = \text{chi2inv}(0.975, 16) = 28.85$$

$$\frac{2T}{\chi_{2r, \frac{\alpha}{2}}^2} \leq \theta \leq \frac{2T}{\chi_{2r, 1-\frac{\alpha}{2}}^2} \Rightarrow \frac{2 \times 669320}{28.85} \leq \theta \leq \frac{2 \times 669320}{6.91} \Rightarrow$$

$$\theta_L = 46400 \leq \theta \leq 193725 \text{ cycles} = \theta_U$$

c) CI for reliability function, if the lifetime is exponentially distributed:

$$e^{-\frac{t}{\theta_L}} \leq R(t) \leq e^{-\frac{t}{\theta_U}} \quad \text{or} \quad e^{-\frac{t}{46419}} \leq R(t) \leq e^{-\frac{t}{193736}}$$

for  $t=4000$  cycles, CI is:

$$e^{-\frac{4000}{46400}} \leq R(4000) \leq e^{-\frac{4000}{193725}} \Rightarrow$$

$$0.9174=91.74\% \leq R(4000) \leq 0.9796=97.96\% \blacktriangle$$

### Example 6.8:

The elements of a random sample  $a$  of a kind of electronic circuit were placed on life test without replacement. The result was  $r=20$  failures and mean of  $MTTF = \hat{\theta} = 5000$ . Find a 95% CI for MTTF. Assume the lifetime is exponentially distributed.

#### Solution

According to Eq. 6-11:

$$\Pr \left[ \frac{2T}{\chi_{2r, \frac{\alpha}{2}}^2} \leq \theta \leq \frac{2T}{\chi_{2r, (1-\frac{\alpha}{2})}^2} \right] = 1-\alpha, T=r \times \hat{\theta} = 20 \times 5000, 1-\alpha=0.9$$

From Table E:  $\chi_{40,0.05}^2 = 55.76, \chi_{40,0.95}^2 = 26.51$

Substituting the numerical values yields:

$\Pr(1793.4 \leq \theta \leq 3772.2) = 0.9$  therefore a 95% CI for the mean life is:  $(1793.4, 3772.2)$ . End of Example  $\blacktriangle$



**Example 6.9<sup>1</sup>** for  $r=1$ :

Suppose the life time of a kind of product is exponentially distributed. Due to the fact that the product is

- 1) expensive and its life test is destructive or
- 2) expensive and a small quantity of it is available

The failure on only one unit of it for life testing is affordable.

$n=5$  units of the product were placed simultaneously on life test and when the first failure occurred at 15.5 hr the test was terminated. Find a 95% confidence interval for MTTF.

**Solution**

The test is of Type II without replacement, therefore:

$$T = (n - r)x_{(r)} + \sum_{i=1}^r x_i, \quad r=1, x_{(1)}=15.5,$$

$$T = (n-r)x_{(r)} + \sum_{i=1}^r x_i = (n-1)x_{(1)} + x_1 = (n-1)x_{(1)} + x_{(1)} = nx_{(1)}$$

From Eq. 6-11:

$$\frac{2T}{\chi_{2r, \frac{\alpha}{2}}^2} \leq \theta \leq \frac{2T}{\chi_{2r, 1-\frac{\alpha}{2}}^2} \Rightarrow \frac{2nx_{(1)}}{\chi_{2, \frac{\alpha}{2}}^2} \leq \theta \leq \frac{2nx_{(1)}}{\chi_{2, 1-\frac{\alpha}{2}}^2}$$

---

<sup>1</sup> from <https://web.cortland.edu/matresearch/CensorDatSTART.pdf>

$$1-\alpha=0.95 \Rightarrow \alpha=0.05,$$

MATLAB  $\Rightarrow$

$$\chi_{2,0.975}^2 = \text{chi2inv}(0.025,2)=0.0506,$$

$$\chi_{2,0.025}^2 = \text{chi2inv}(1-0.025,2)=7.3778$$

$$n=5, x_{(1)}=15.5 \Rightarrow \frac{2 \times 5 \times 15.5}{7.3778} \leq \theta \leq \frac{2 \times 5 \times 15.5}{0.0506} \Rightarrow 21 \leq \theta \leq 3063$$

End of Example ▲

### 6-6-1 Lower-bound confidence interval(CI) for mean of exponential distribution

After a life test, the lower-bound  $1 - \alpha$  CI for the mean of an exponentially distributed lifetime could be calculated from (K&L page257):

$$\theta \geq L = \frac{2T}{\chi_{\alpha,2r}^2} \quad (6-12)$$

Where  $T$  is total test schedule and  $r$  the number of failures occurred during the test

### 6-6-2 The confidence interval for the time during which fraction $p$ of exponentially-distributed-life products fail

Sometimes we would like construct a confidence interval for the time or the kilometer or the temperature or...denoted by  $t_p$  up to which the fraction of the products fail.  $t_p$ , in other words is such that  $R(t_p) = 1 - p$  where  $R(\cdot)$  is the reliability function.

Suppose the lifetime distribution of the product is exponential with mean  $\theta$  then  $e^{-\frac{t_p}{\theta}} = 1 - p$  or  $t_p = \theta \times \ln\left(\frac{1}{1-p}\right)$  and if the estimate for  $\theta$  is denoted by  $\hat{\theta}$  then we have the following estimate for  $t_p$ :  $\hat{t}_p = \hat{\theta} \times \ln\left(\frac{1}{1-p}\right)$

If we have a  $1-\alpha$  CI such as  $\theta_L < \theta < \theta_U$  for the mean lifetime, then the following interval would be  $1-\alpha$  CI for  $t_p$ :

$$\theta_L \times \ln\left(\frac{1}{1-p}\right) < t_p < \theta_U \times \ln\left(\frac{1}{1-p}\right) \quad (6-13-1)$$

$$\theta_L \times \ln\left(\frac{1}{R}\right) < t_R < \theta_U \times \ln\left(\frac{1}{R}\right) \quad (6-13-2)$$

where

$t_p = t_R$  is when (the time or the kilometer or the temperature or...) that fraction  $p$  of the working product fail or fraction  $R=1-p$  of them do not.

Last part of problem 6 of this chapter exercises uses Sec. 6.6.2.

## 6-7 Reliability Acceptance Sampling Plans

During the past years several researches have been done on the subject of sampling from a lot of products to accept or reject it based on product lifetime. Single, double and multiple sampling plans have been developed in this regard which are called Reliability Acceptance Sampling Plans (RASP), utilized to inspect the quality of a lot for acceptance.

Among the first researches for life testing based on samples taken from populations whose life follow exponential distribution is the reference H108 Handbook<sup>1</sup>

This 88-page handbook is primarily concerned with three different types of life test sampling plans and includes a number of accompanying tables. These plans are

- 1) test terminated upon the occurrence of pre-assigned number of failures,
- 2) test terminated at a predesigned time, and
- 3) sequential life testing plans.

Also provided are a set of 90 operating characteristic (oc) curves applicable for the above three test plans. Some descriptions of the sampling plans of this handbook is given in the author's quality control book<sup>2</sup>.

Table 6-2 of this chapter is a sample of the handbook tables. This table helps to determine single sampling plans for inspecting lots.

Here single sampling plans are schemes in which a decision to accept or reject an inspection lot is based on the inspection of a single sample. A single sampling plan consists of a single sample of size  $n$  placed on life test for a time  $T$  hours, with

---

<sup>1</sup>H108., Quality Control and Reliability Handbook (Interim) Sampling Procedures and Tables for Life and Reliability Testing (Based on Exponential Distribution),, in (Supply and Logistics)

<sup>2</sup> <https://opentextbc.ca/oerdiscipline/chapter/industrial-engineering> or <https://archive.org/details/statistical-methods-august-2020-bazargan> or <https://opentextbc.ca/oerdiscipline/chapter/statistics/>

associated acceptance and rejection number( $r$ ). Note that during the test time failed items are replaced with new ones unless the number of items has exceeded  $r-1$ .

### 6-7-1 Type I&II errors of Sampling plans

The Inspection of a lot for accepting or rejecting using sampling plans have might encounter errors. These inspection errors are classified into two categories: Type I and Type II. Type I error results in the rejection of a conforming lot, while Type II error causes the inspector to accept a defective lot. Here (in a single sampling with parameters  $n$  and  $c$ ) The type I &II errors could be described as follows:

When the lot possesses a conforming reliability such as  $R_1$ , and the plan rejects it Type I error ( rejecting conforming lots) occurs with the following probability.

$$\alpha = 1 - \sum_{x=0}^c \binom{n}{x} (1 - R_1)^x R_1^{n-x} \quad (6 - 14)$$

When the lot possesses a nonconforming reliability such as  $R_2$ , and the plan accepts it, Type II error ( accepting nonconforming lots) occurs with the following probability:

$$\beta = \sum_{x=0}^c \binom{n}{x} (1 - R_2)^x R_2^{n-x} \quad (6 - 15)$$

### 6-7-2 Design of single plans using Table 6-2

Given the test time  $T$ , type-I error probability( $\alpha$ ) for the desired mean  $\theta_0$  and type-II error probability( $\beta$ ) for the undesired mean  $\theta_1$ , calculate  $\frac{\theta_1}{\theta_0}$  &  $\frac{T}{\theta_0}$ . Read the plan indices ( sample size  $n$  and rejection number  $r$  ) from Table 6-2.

### Example 6.10

Design a plan whose test is of type "life tests terminated at pre-assigned time" in such a way the test time does not exceed  $T=500$  hr . The plan is wanted to accept 90% the lots having mean life  $\theta_0 = 10000$  hr ( $\alpha = 0.10$ ), and to reject 95% of the lots with mean life  $\theta_1 = 2000$ hr ( $\beta = 0.05$ ). The life is assumed to be exponentially distributed.

### Solution

$$\frac{\theta_1}{\theta_0} = \frac{2000}{10000} = \frac{1}{5}, \quad \frac{T}{\theta_0} = \frac{500}{10000} = \frac{1}{20}$$

**Table 6-2 Acceptance Sampling Plans for some  $\alpha, \beta, \frac{T}{\theta_0}$  &  $\frac{\theta_1}{\theta_0}$  with a test terminated at pre-assigned time with replacement (Table 2C-4 in H108 Handbook)**

$\theta_1 / \theta_0$	$r$	$T / \theta_0$				$r$	$T / \theta_0$			
		$\frac{1}{3}$	$\frac{1}{5}$	$\frac{1}{10}$	$\frac{1}{20}$		$\frac{1}{3}$	$\frac{1}{5}$	$\frac{1}{10}$	$\frac{1}{20}$
		<b>n</b>	<b>n</b>	<b>n</b>	<b>n</b>		<b>n</b>	<b>n</b>	<b>n</b>	<b>n</b>
		$\alpha = 0.01, \beta = 0.01$					$\alpha = 0.05, \beta = 0.01$			
2thirds	136	3	551	1103	220	9	23	397	795	1591
1half	46	9	158	317	634	3	72	120	241	483
1third	19	3	51	103	206	1	25	38	76	153
1 fifth	9	1	17	35	70	7	9	16	32	65
1tenth	5	4	6	12	25	4	4	6	13	27
		$\alpha = 0.01, \beta = 0.05$					$\alpha = 0.05, \beta = 0.05$			
2thirds	101	2	395	790	158	6	16	270	541	1082
1half	35	6	113	227	454	2	47	78	157	314
1third	15	2	37	74	149	1	16	27	54	108
1 fifth	8	8	14	29	58	5	6	10	19	39
1tenth	4	3	4	8	16	3	3	4	8	16
		$\alpha = 0.01, \beta = 0.1$					$\alpha = 0.05, \beta = 0.1$			
2thirds	83	1	316	632	126	5	13	216	433	867
1half	30	5	93	187	374	1	37	62	124	248
1third	13	1	30	60	121	8	11	19	39	79
1 fifth	7	7	11	23	46	4	4	7	13	27
1tenth	4	2	4	8	16	3	3	4	8	16
		$\alpha = 0.01, \beta = 0.25$					$\alpha = 0.05, \beta = 0.25$			
2thirds	60	1	217	434	869	3	77	129	258	517
1half	22	3	62	125	251	1	23	38	76	153
1third	10	1	20	41	82	6	7	13	26	52
1 fifth	5	4	7	13	25	3	3	4	8	16
1tenth	3	2	2	4	8	2	1	2	3	7
		$\alpha = 0.1, \beta = 0.01$					$\alpha = 0.25, \beta = 0.01$			
2thirds	77	1	329	659	131	5	14	234	469	939
1half	26	5	98	197	394	1	42	70	140	281
1third	11	2	35	70	140	7	15	25	50	101
1 fifth	5	7	12	24	48	3	5	8	17	34
1tenth	3	3	5	11	22	2	2	4	9	19
		$\alpha = 0.1, \beta = 0.05$					$\alpha = 0.25, \beta = 0.05$			
2thirds	52	1	214	429	859	3	84	140	280	560
1half	18	3	64	128	256	1	25	43	86	172
1third	8	1	23	46	93	5	10	16	33	67
1 fifth	4	5	8	17	34	2	3	5	10	19
1tenth	2	2	3	5	10	2	2	4	9	19
		$\alpha = 0.1, \beta = 0.1$					$\alpha = 0.25, \beta = 0.1$			
2thirds	41	9	165	330	660	2	58	98	196	392
1half	15	3	51	102	205	8	17	29	59	119
1third	6	9	15	31	63	4	7	12	25	50
1 fifth	3	4	6	11	22	2	3	4	9	19
1tenth	2	2	2	5	10	1	1	2	3	5
		$\alpha = 0.1, \beta = 0.25$					$\alpha = 0.25, \beta = 0.25$			
2thirds	25	5	94	188	376	1	28	47	95	190
1half	9	1	27	54	108	5	10	16	33	67
1third	4	5	8	17	34	2	2	4	9	19
1 fifth	3	3	5	11	22	1	1	2	3	6
1tenth	2	1	2	5	10	1	1	1	2	5

Table 6-2 gives  $n=34$  &  $r=4$  from with  $\frac{T}{\theta_0} = \frac{1}{20}$ ,  $\frac{\theta_1}{\theta_0} = \frac{1}{5}$ ,  $\alpha = 0.10$ , &  $\beta = 0.05$ . That is a random sample of size 34 is taken from the lot and its items are put on life tested simultaneously; unless the number of failures before 500 hr is equal to  $r=4$  if before the end of 500-hr test, a failure occurs it is replaced by a new one, and the total number of failures is updated. End of Example▲

### 6-7-3 The operating characteristic (OC) curve of single sampling plans

Remember that in quality control the so called OC curves for an acceptance sampling plan plots the probability of accepting a lot MTBF or the reliability of the products. An application of the OC curve which is plotted for single, double and multiple sampling plans is providing easy comparison ( $P_a$ ) versus a parameter related to the lot such as MTTF or of plans. What follows next is plotting the OC curve for single sampling plans.

#### *6-7-3-1 Operating Characteristic curve for single sampling plans ( $P_a$ versus Reliability)*

In a single acceptance sampling plan, we take a sample of size  $n$  from our lot and place all the  $n$  products on life test for a period of time  $T$  as prescribed by the plan. If the reliability of the products for the time  $T$  is  $R$ , the failure probability is  $p=1-R$ . The probability that a large lot is accepted in a single sampling plan of size  $n$  and acceptance number  $c$  is calculated from:



$$Pa = \Pr(X \leq c) = \sum_{x=0}^c \binom{n}{x} (1-R)^x R^{n-x} \quad (6-16)$$

This equation, which gives the probability of the failure of at most  $c$  products during the test, could be used to plot OC curve ( $Pa$  versus  $R$ ).

### Example 6-11 (plotted versus $R$ ) OC curve: $Pa$

A plan with  $n=10$ , acceptance number  $c=2$  and  $T=100$  is used to accept or reject a large lot.

a) Plot the OC curve of the plan in such a way that  $Pa$  be plotted versus the product Reliability.

b) If the lifetime of the products are exponentially distributed with mean 950 hours. Find the probability of accepting a large lot of this product.

### Solution

a) The following table shows the values of  $Pa$  for 11 values of  $R$  calculated using Eq. 6-16 or MATLAB command `binocdf`.

R	0	0.1	0.2	0.3	0.4	0.5	0.6	0.7	0.8	0.9	1
$P_a$	0	0	0.001	0.0016	0.012	0.055	0.17	0.39	0.68	0.93	1

and the following MATLAB commands plot the OC curve (see Fig. 6.1) `R=0:0.1:1; Pa= binocdf(2,10,1-R); plot(R,Pa)`.

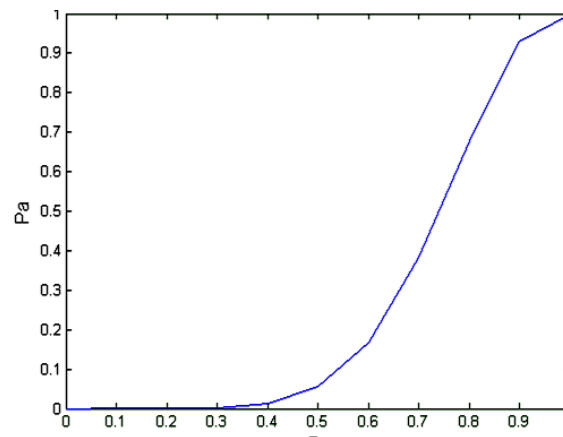

Fig. 6.1 OC curve for plan n=10, c=2

b) the lifetime is exponentially distributed then for  $T=100 \Rightarrow$

$$R = e^{-\frac{100}{950}} = 0.93. \text{ From the curve or the table } Pa=0.93.$$

### 6-7-3-2 Operating Characteristic curve for single sampling plans (Pa versus mean lifetime)

The following example illustrates how to plot the OC curve an acceptance sampling plan for inspecting a lot. If the sample meets a special criterion, the lot will be accepted.

#### **Example 6-12** (OC curve: Pa plotted versus mean lifetime)

(based on Grant & Leevenworth, 1988 page 585)

Consider the following acceptance sampling plan to be taken from a largish lot and plot its OC curves using various MTTF. The plan is as follows:

Take a random sample of 22 units from the lot of product, and apply life test. Whenever an item fails, replace it with another item selected at random from the lot. If the test continues for 500 hr with no more than 2 failures, accept the lot. If 3 failures [ or more] occur before 500 hr of testing. Terminate the test and reject the lot.

### Solution

We suppose simultaneous testing of 22 units for 500 hours or 110 units for 100 hours or 11000 units for 1 hour give the same results. To plot the OC curve, note that totally we have  $22 \times 500 = 11000$  item-hours with acceptance number  $c = 2$ . Assume the failure probability is the same for all 11000 unit-hours. Define the problem as a single acceptance sampling plan with  $n = 11000$ , and  $c = 2$ , let:

$X$  = number failures in 11000 unit-hours during 1 hour test,  
then  $P_a = \Pr(X \leq 2 | \text{given } \lambda)$  The probability of failure of one unit in an hour,

or

the failure rate of one unit per hour or the failure probability of one unit-hour

or

the proportion of binomial distribution  $p'$ )

$= \Pr(X \leq 2 | \text{given mean of number of failures in a sample of } 11000 = 11000\lambda = np')$

Here  $\lambda$  has a value less than 1 and is interpreted as the probability of the failure of one unit in an hour.

The failure rate  $\lambda$  takes the place of fraction nonconformities (Grant & Leavenworth, 1988, page 586). Then the probability

that a unit fails in an hour is  $\lambda$ . To plot the OC curve, the exact value of lot acceptance probability corresponding to a particular  $p'$  could be calculated from:  $P_a = \text{binocdf}(2, n=11000, p'=\lambda)$ .

In MATLAB, the approximate probability for various  $np'$  may be calculated from  $P_a \cong \text{poisscdf}(2, np')$ .

As stated earlier, in chapter 10,  $P_a$  were plotted versus  $p'$ . But in this chapter the horizontal axis is either the product mean life ( $\theta = \frac{1}{\lambda}$ ) or the product reliability. Table 6-3 shows the probabilities for some values of  $\theta$ . Figure 6-2 shows the corresponding OC curve.

**Table 6-3 Acceptance probability of in Example 14.15 for various mean lifetimes** (Grant Leavenworth, 1988, Page 586)

Calculation of OC curve for acceptance sampling plan requiring 11,000 item hours of life testing with an acceptance number of 2. Calculation assumes that the failure rate  $\lambda$  is independent of the age of the item tested

Failure rate per hour, $\lambda = p'$	Mean life $\theta = \frac{1}{\lambda}$ hours	Expected average number of failures in 11,000 test hours ( $np' = 11000\lambda$ )	Probability of acceptance (probability of 2 or less failures) from Pois. Dist.
0.00002	50000	0.22	0.999
0.00005	20000	0.55	0.982
0.00006	16667	0.66	0.971
0.00008	12500	0.88	0.939
0.00010	10000	1.1	0.900
0.000125	8000	1.375	0.839
0.00015	6667	1.65	0.770
0.00020	5000	2.2	0.623
0.00025	4000	2.75	0.480
0.00030	3333	3.3	0.360
0.00040	2500	4.4	0.185
0.00050	2000	5.5	0.088
0.00060	1667	6.6	0.040
0.00080	1250	8.8	0.007

To know how  $P_a$  is calculated, suppose  $\lambda = 0.0003$ ; since  $n=11000$  then  $np' = 11000\lambda = 3.3$ . The approximate value for  $P_a$  from Poisson CDF table :  $P_a = \Pr(X \leq 2) = 0.359 \cong 0.360$ .

The exact value of  $P_a$  is calculable from MATLAB :

$$P_a = \Pr(\leq 2) = \text{binocdf}(2, 11000, 0.0003) = 0.3594.$$

The following MATLAB commands plots the OC curve.

```
p=1/17000:.00001:1/1000;Pa=binocdf(2,11000,p);plot(1./p,Pa)
```

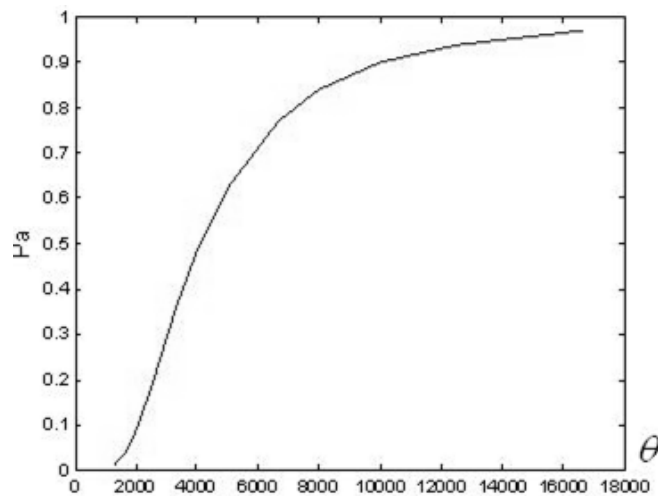

Fig. 6-2 OC curve for Example 14.15  
(acceptance probability versus mean life).

End of example▲

## 6-8 statistical hypothesis testing on mean and minimum lifetime

In life testing, situations frequently arise where it is important to determine if a new system meets a design goal or an

established standard. This leads to the area of statistical inference called hypothesis testing (K&L page 263). Chapter 1 introduced Bartlett's goodness of fit test for the assessment of the hypothesis that the distributional form was exponential. Here 2 tests on the mean and the minimum lifetime are presented.

### 6-8-1 Test of hypothesis on minimum life of an exponentially distributed lifetime (K&L page 263)

To deal with the following hypotheses on minimum life ( $\delta$ ) of an exponentially distributed lifetime,  $H_0: \delta = 0$   $H_1: \delta > 0$  given significance level (Type I error probability) of  $\alpha$ ,

Take a random sample of size  $n$ , and

Place all of the  $n$  products simultaneously on life test, without replacement,

Continue the test until the time that  $r^{\text{th}}$  failure occurs ( $r \leq n$  is a predetermined number).

Prepare an ordered sample of the failure times:  $x_{(1)}, x_{(2)}, \dots, x_{(r)}$ .

Calculate the mean lifetime from

$$\hat{\theta}' = \frac{(n-r)(x_{(r)} - x_{(1)}) + \sum_{i=1}^r (x_{(i)} - x_{(1)})}{r-1}; \text{ calculate } F_0 = \frac{n \times x_{(1)}}{\hat{\theta}'},$$

Using Table A at the end of the book or MATLAB command  $\text{finv}(1-\alpha, 2, 2r-2)$ , find  $F_{\alpha, 2, 2r-2}$ , the critical value of F distribution for the given  $\alpha$ .

$$H_0 \text{ is rejected if } F_0 = \frac{n \times x_{(1)}}{\hat{\theta}'} > F_{\alpha, 2, 2r-2} \quad (6-17)$$

Note that if  $H_0$  is rejected, the mean lifetime in this case is estimated by  $\hat{\theta}'$ . The minimum life is estimated from

$$\hat{\delta} = x_{(1)} - \frac{\hat{\theta}'}{n} \text{ and the reliability is estimated from } e^{-\frac{t-\hat{\delta}}{\hat{\theta}'}} \text{ (K\&L page 258-9).}$$

### Example 6-13 (K&L page 263)

The data in the following table represents cycles to failure for throttle return springs. Twenty springs were tested under conditions similar to those encountered in actual use. The test was truncated at the time of the tenth failure. Can we conclude with 95% confidence that the minimum life ( $\delta$ ) is greater than zero?

failure no. (i)	1	2	3	4	5	6	7	8	9	10
Cycles to failure $x_{(i)}$	190437	245593	277761	432298	530100	626300	1043307	1055528	1221393	2099199

### Solution

$$\begin{cases} H_0 : \delta = 0 \\ H_1 : \delta > 0 \end{cases}$$

$$\hat{\theta}' = \frac{(n-r)(x_{(r)} - x_{(1)}) + \sum_{i=1}^{10} (x_{(i)} - x_{(1)})}{r-1} = \frac{(15-10)(2099199-190437) + 1908762}{10-1} + \frac{(190437-190437) + (245595-190437) + \dots + (2099199-190437)}{10-1} \Rightarrow \hat{\theta}' = 2767421$$

$$F_0 = \frac{nx_{(1)}}{\hat{\theta}'} = \frac{15 \times 190437}{2767421} = 1.03$$

The critical value of F is not in Table A, Using MATLAB:

$$F_{\alpha, 2, 2r-2} = F_{0.05, 2, 18} = \text{finv}(0.95, 2, 18) = 3.5546 \quad F_0 < F_{0.05, 2, 18}$$

$H_0$  is not rejected i.e. it is not concluded minimum life( $\delta$ ) is other than zero. End of example ▲

### 6-8-2 Test of hypothesis on mean lifetime and failure rate concerning exponential distribution (K&L page 263)

To test the following statistical test of hypothesis on mean lifetime( $\theta$ ) of an exponentially distributed product with significance level of  $\alpha$

$$H_0 : \theta \leq \theta_0$$

$$H_1 : \theta > \theta_0$$

Perform the following steps:



1. Take a random sample of size  $n$ , and
2. Place all of the  $n$  products simultaneously on life test, without replacement
3. Continue the test until the time that  $r^{\text{th}}$  failure occurs ( $r \leq n$  is a predetermined number).
4. Prepare the ordered sample of the failure times:  $x_{(1)}, x_{(2)}, \dots, x_{(r)}$ .
5. Estimate the mean lifetime from  $\hat{\theta} = \frac{(n-r)x_{(r)} + \sum x_{(i)}}{r}$
6. Calculate  $\chi_0^2 = \frac{2r\hat{\theta}}{\theta_0}$ ,
7. Using Table E at the end of the book or MATLAB command `chi2inv( $\alpha, 2r$ )`, find  $\chi_{1-\alpha, 2r}^2$  i.e. the critical value of chi-squared distribution for the given  $\alpha$ .
8. Reject  $H_0$  if

$$\chi_0^2 = \frac{2r\hat{\theta}}{\theta_0} > \chi_{\alpha, 2r}^2 \quad (6-18)$$

The criteria of the above test is applicable for performing the test on the failure rate ( $\lambda$ ) of exponentially distributed products i.e.  $H_0: \lambda \leq \lambda_0$   $H_1: \lambda > \lambda_0$ .

**Example 6-14**

A random sample of certain exponentially-distributed-life product was placed on a life test without replacement. The test was terminated when the tenth failure occurred. Other data are ;

$$n = 15, \sum x_{(i)} = 18217915, x_{(10)} = 2099199 .$$

Perform the following test of hypothesis with  $\alpha = 5\%$  on the mean lifetime( $\theta$ ):

$$H_0: \theta \leq \theta_0 = 10^6 \text{ cycles}$$

$$H_1: \theta > \theta_0$$

**Solution**

$$\chi_0^2 = \frac{2r\hat{\theta}}{\theta_0} \quad r = 10, \quad n = 15, \alpha = 5\%$$

The test is of non-replacement failure-terminated type, therefore according to Eq. 6.6

$$\hat{\theta} = \frac{(n-r)x_{(r)} + \sum x_i}{r} = 2871391, \chi_0^2 = \frac{(2)(10)(2871391)}{10^6} = 57$$

Table E or MATLAB command `chi2inv(0.95,20)` yields:

$$\chi_{\%5,20}^2 = 31.41. \quad \chi_0^2 > \chi_{\%5,20}^2 \Rightarrow H_0: \theta \leq \theta_0 \text{ is strongly rejected, \&}$$

$H_1: \theta > \theta_0$  is not rejected  $\blacktriangle$

### 6-8-3 Comparison of two designs

An engineer would like to compare 2 designs of a product. From Design 1 a random sample of size  $n_1$  and from Design 2 a random sample of size  $n_2$  is taken and placed on life test. The tests are terminated when  $r_1^{th}$  failure occurs in the sample of Design 1 and  $r_2^{th}$  failure occurs in the sample of Design 2.  $r_1 \leq n_1$  and  $r_2 \leq n_2$  are predetermined truncation points.

Suppose the failure times are  $S_1 = \{x_{1(1)}, x_{1(2)}, \dots, x_{1(r_1)}\}$ ,

$S_2 = \{x_{2(1)}, x_{2(2)}, \dots, x_{2(r_2)}\}$ . For simplicity  $S_1$  will be assigned such that  $x_{1(1)} \leq x_{2(1)}$ . If the lifetimes are **exponentially distributed**, to compare their mean lifetimes  $\theta_1, \theta_2$  i.e. performing the following test:

$$H_0 : \theta_1 = \theta_2$$

$$H_1 : \begin{cases} \theta_1 \neq \theta_2 \\ \theta_1 < \theta_2 \end{cases}$$

The statistic under the null hypothesis is (K&L p265):

$$F_o = \frac{r_1 - 1}{r_2 - 1} \times C \quad (6-19)$$

where

$n_1$	Sample size taken from Design 1
$n_2$	Sample size taken from Design 2
$r_1$	Truncation point of the test of Sample 1 $r_1 \leq n_1$ Terminate the lifetest when $r_1^{th}$ failure occurs

$r_2$	Truncation point of the test of Sample 1 $r_2 \leq n_2$ Terminate the lifetest when $r_2^{th}$ failure occurs
$x_{1(r_1)}, x_{2(r_2)}$	Occurrence time of $r_1^{th}$ & $r_2^{th}$ failure in Design 1 & 2 respectively
$x_{2(1)}, x_{1(1)}$	The occurrence time of first failure in Design 1 & 2 respectively
$x_{1(j)}, x_{2(j)}$	Elements of the samples
$F_{\frac{\alpha}{2}, 2r_2 - 2, 2r_1 - 2}$	$\frac{\alpha}{2}$ -significance-level critical value of an F distributions with $2r_2 - 2, 2r_1 - 2$ deg of free. Obtainable from Table A or MATLAB command $finv(1 - \frac{\alpha}{2}, 2r_2 - 2, 2r_1 - 2)$
<b>C</b>	$C = \frac{(n_2 - r_2)(x_{2(r_2)} - x_{2(1)}) + \sum_{j=1}^{r_2} (x_{2(j)} - x_{2(1)})}{(n_1 - r_1)(x_{1(r_1)} - x_{1(1)}) + \sum_{i=1}^{r_1} (x_{1(i)} - x_{1(1)})}$

**Rejection Criteria:**

For $H_1 : \theta_1 \neq \theta_2$	Reject $H_0$ if $F_o$ is outside $\left[ F_{1-\frac{\alpha}{2}, 2r_2 - 2, 2r_1 - 2} \quad F_{\frac{\alpha}{2}, 2r_2 - 2, 2r_1 - 2} \right]$
For $H_1 : \theta_1 < \theta_2$	Reject $H_0$ if $F_o > F_{\alpha, 2r_1 - 2, 2r_2 - 2}$

To test if the failure rates of the 2 designs are significantly different or not i.e.  $H_0 : \lambda_1 = \lambda_2$ , the above test could be used.  
 $H_1 : \lambda_1 \neq \lambda_2$

**It is our duty to act in such a manner  
that can be universalized i.e.  
we would want everyone else to act  
in a similar manner**

(Kant)

## Exercises<sup>1</sup>

In the problems, if the type of distribution is needed and not specified, exponential distribution is assumed

1. The weather radar system on a commercial aircraft has an MTBF of 1,140 hours. Assume an exponential time to failure distribution and answer the following questions:
  - (a) What is the probability of failure in a 4-hour flight?
  - (b) What is the maximum length of flight such that the reliability will not be less than 0.99? (Assume that the system is in continuous operation during flight.)
2. The MTBF of a kind of tank is 810 kilometers. Assuming an exponential distribution:
  - a) What is the maximum mission length such that there will be a 0.98 chance of the tank returning?
  - b) What is the probability of the tank returning from a 160 kilometer mission?
  - c) How many tanks should be sent out on the 160 kilometer mission to obtain a probability of 0.99 that at least five tanks will arrive at the target area (assume 80 kilometers to target).
3. Ten engines of a new design were each driven the equivalent of 50,000 kilometers. Odometer readings were recorded whenever an unscheduled maintenance

---

<sup>1</sup> Exercises 1 through 8 are from Chap. 9 K&L page 269 problems 1,2,3,4,6,8,9,10

action occurred. The odometer readings for each vehicle follow:

Motor no.	Odometer readings						
	1	220	11970	21397	27766		
2	45270	48836					
3	25695	25989	30980	32769	47459		
4	4200	14672	21831	29187	31964	36535	44094
5	3900	29147	31613	37524	43601	45208	
6	1275	21183	23649	33348	40907		
7	3730	6300	11840				
8	22565	22710	28301	31628	45784	47213	
9	12759	14548	19539	41108	44550		
10	12212	18727	41854	42169	47996		

- a) Can the data be represented by the exponential distribution? ( $\alpha=0.1$ )
- b) If answer to part (a) is yes, estimate the MTBF.

4. The following data represent kilometers to failure:

43000	27200	10600	12400
27000	4100	200000	18200
68000	40500	109000	14200
46000	2600	2400	24500

- a) Assess the feasibility of using the exponential distribution to model this situation. Assuming that the exponential is applicable:
- b) estimate the MTBF;
- c) set a 90% lower confidence limit on the 10% failure kilometer.
- d) With 90% confidence, quote the 2,400 km reliability.

5. An automobile was driven over a 120,000 kilometer test course. The following represent odometer readings at which a particular type of failure

4123	27720	63582
4497	28496	66057
10506	40887	100763
12317	48323	

Assuming an exponential distribution as representative, is there any evidence that the failure rate in the first 40,000 km is different than in the last 80,000 km? ( $\alpha=0.1$ ).

6. For a test vehicle, major electrical failures occurred at the following kilometers

63	17393	23128
114	18707	24145
14820	19179	33832
16105	22642	34345

The vehicle was driven a total of 36,000 kilometers.

- Estimate the MTBF.
  - Determine the 90% two-sided confidence interval for the MTBF.
  - Estimate the reliability function.
  - Determine the 95% lower confidence limit for the 1,200 kilometer reliability.
  - With 90% confidence estimate the kilometer at which 10% of the population will fail.
7. In 600,000 test kilometers accumulated on 6 vehicles, a total of 69 failure occurred. Assuming an exponential failure distribution:

- a) Estimate the MTB
  - b) Find the 90% lower confidence limit on the MTBF.
  - c) Find the 90% lower confidence limit on the reliability function.
8. A transmission valve operated for 9,276 cycles before the test was discontinued. The test was stopped because an oil pump failure caused the valve to burn out.
- a) Set a 90% lower confidence limit on the MTBF.
  - b) A second valve of a different design failed at 19,460 cycles. Management would like your recommendation as to which valve is best. What would be your answer?
9. (K&L pp 239-240) A device was placed on 245-hr lifetest had 20 failures occurred on the following times:

Failure times during 245-hr lifetest			
21.2	74.7	108.6	157.4
49.9	76.8	112.9	164.7
59.2	84.3	127.0	196.8
62	91	143.9	214.4
74.6	93.3	151.6	218.9

Ignoring the repair times, could we say that Time Between Failure (TBF) follows an exponential distribution?

Hint: At first compute the TBFs which are the following values

Time between failures			
21.2	0.1	15.3	5.8
47.9-21.2=26.7	2.1	4.3	7.3
11.3	7.5	14.1	32.1
2.8	6.7	16.9	17.6
12.6	3.2	7.7	4.5



10. Plot<sup>1</sup> the OC curve ( $P_a$  versus MTBF) for the following sampling plan:

Twenty units are randomly taken from a largish sample, and simultaneously placed on lifetest. Whenever an item fails, it is replaced with another item selected at random from the lot. If the test continues for 500 *hr* with not more than 2 failures accept the lot. If 3 failures occur before the 500 *hr* of testing, reject the lot and terminate the test.

---

<sup>1</sup> Solution on Page 586 Grant &Leavnworth(1988)

Chapter 7  
Dynamic  
Models,  
Availability,  
Application of  
Markov Chain to  
Reliability

# 7

## **Dynamic Models+ Availability, Application of Markov Chain**

### **Aims of the chapter**

This chapter deals with time related reliability models or dynamic models. Series systems and two but types of parallel redundancy, namely active redundancy and standby redundancy are introduced. Some system attributes such as maintainability, serviceability as well as availability are defined. The chapter also points out the application of Markov chains to reliability analysis.

### **7.1 Dynamic Models in Reliability**

Dynamic models (time dependent) are important, realistic, and more appropriate than static models which were covered in chapter 2. Incorporating time into static models , this chapter deals with series, weakest link, active parallel, standby parallel(perfect switching and imperfect switching).

#### **7-1-1 Series Systems**

Series systems are those in which all components are required to be in a state of functioning for the system to be

functioning. If a system is assembled of  $m$  components in series, its reliability( $R_{sys}$ ) is:

$$R_{sys}(t) = \prod_{i=1}^m R_i(t) \quad (7-1)$$

where  $R_i(t), i = 1, \dots, m$  are the reliabilities of the components.

### Proof No.1

$$h_{sys}(t) = \frac{-R'_{sys}(t)}{R_{sys}(t)} \quad R_{sys}(t) = \prod_{i=1}^m R_i(t) = \prod_{i=1}^m [1 - F_i(t)]$$

$$R'_{sys}(t) = \sum_{i=1}^m \left( -f_i(t) \prod_{\substack{j=1 \\ j \neq i}}^m R_j(t) \right) = - \sum_{i=1}^m \left( f_i(t) \prod_{\substack{j=1 \\ j \neq i}}^m R_j(t) \right)$$

Therefore

$$h_{sys}(t) = - \frac{R'_{sys}(t)}{R_{sys}(t)} = \frac{\sum_{i=1}^m \left( f_i(t) \prod_{\substack{j=1 \\ j \neq i}}^m R_j(t) \right)}{\prod_{i=1}^m R_i(t)} \Rightarrow$$

$$h_{sys}(t) = \frac{f_1(t)}{R_1(t)} + \dots + \frac{f_m(t)}{R_m(t)} = \sum_{i=1}^m \frac{f_i(t)}{R_i(t)} = \sum_{i=1}^m h_i(t)$$

**Proof No.2**

$$R(t) = e^{-\int_0^t h(\tau) d\tau} \equiv \int_0^{\infty} h(\tau) d\tau = -\ln R(t), \quad h(t) = -\frac{d}{dt} \ln R(t)$$

$$R_{sys}(t) = R_1(t) \times \dots \times R_n(t) \Rightarrow \ln R_{sys}(t) = \sum \ln R_i(t) \Rightarrow$$

$$\frac{d}{dt} \ln R_{sys}(t) = \sum \frac{d}{dt} \ln R_i(t) = \sum_{i=1}^m h_i(t)$$

$$h_{sys}(t) = \frac{-d}{dt} \ln R_{sys}(t) = -\left[-\sum h_i(t)\right] \Rightarrow h_{sys}(t) = \sum_{i=1}^m h_i(t)$$

End of proof ■

Now Suppose the failure rate functions of  $m$  independent components of a system are:  $h_i(t) = \lambda_i + C_i t^k$ ,  $i = 1, 2, \dots, m$  where  $C_i, \lambda_i$  &  $k$  constant values.

Then using Eq. 1-14-1

$$R_i(t) = e^{-\int_0^t h_i(\tau) d\tau} = e^{-\lambda_i t - C_i \frac{t^{k+1}}{k+1}}$$

And using Eq. 7-1

$$R_{sys}(t) = \exp\left(-t \sum_{i=1}^m \lambda_i - \frac{t^{k+1}}{k+1} \sum_{i=1}^m C_i\right) \quad (7-2-1)$$

Let  $\lambda^* = \sum_{i=1}^m \lambda_i$ ,  $c^* = \sum_{i=1}^m C_i$ ,  $T = t \sum_{i=1}^m \lambda_i = \lambda^* t$  then (K&L p39)

$$R_{sys}(t) = e^{-\left(\lambda^* t + \frac{c^*}{\lambda^*} \times \frac{1}{k+1} \times \frac{(\lambda^* t)^{k+1}}{\lambda^{*k}}\right)}$$

For large  $m$  it could be shown that :

$$\lim_{m \rightarrow \infty} R_{sys}(t) = e^{-T} = e^{-t \sum_{i=1}^m \lambda_i} = e^{-t \lambda^*} \quad (7-2-2)$$

That is the time between failure of a series system, with largish number of components with failure rate function

$h_i(t) = \lambda_i + C_i t^k$ , is exponentially distributed with parameter  $\sum_{i=1}^m \lambda_i$ .

Note that if  $h_i(t) = \lambda_i$  Eq. 7-2-2 holds regardless of the value of  $m$ . By substituting  $C_i = 0$  in Eq. 7-2-1 this fact could easily be verified.

### Example 7-1

The failure rates of an  $n$ -component series system are constant values  $\lambda_i, i=1..n$ . The components are independent. Find the failure rate function, the reliability function and MTBF of the system.

#### Solution

The failure rates of the components are constant i.e. the lifetime distributions are exponential. The lifetime of a series configuration equals the lifetime of the component that has the minimum life among the components. On the other hand the minimum of some exponentially distributed random variables has an exponential distribution. Therefore the distribution of this system is exponential with the following functions:

According to Eq. 7-2, the system failure rate function ( $h_{\text{sys}}$ ) is

$$h_{\text{sys}}(t) = \sum_{i=1}^n h_i(t) = \sum_{i=1}^n \lambda_i = \text{constant}$$

Then the reliability function is:

$$R_{\text{sys}}(t) = e^{-t \times \sum \lambda_i} \quad (7-4-1)$$

The mean lifetime of this series system is

$$MTBF = \frac{1}{\sum_{i=1}^n \lambda_i} = \frac{1}{\sum_{i=1}^n \frac{1}{MTBF_i}} = \left( \sum_{i=1}^n \frac{1}{\theta_i} \right)^{-1} \quad (7-4-2)$$

where  $MTBF_i = \theta_i = \frac{1}{\lambda_i}$ . End of Example ▲

### Mean lifetime and reliability function of a series system of identical components with failure rate $\lambda$

Consider a series system having  $n$  independent components whose lifetimes are exponentially distributed with mean  $MTBF_{\text{part}} = \frac{1}{\lambda}$ , then according to Eq. 7-4-1&2 mean time between failures of the system and the reliability function the system are:

$$R_{\text{sys}}(t) = e^{-n \lambda t} \quad (7-4-3)$$

$$MTBF = \frac{1}{n \lambda} = \frac{MTBF_{\text{part}}}{n} \quad (7-4-4)$$

### 7-1-2 Series Chain Model or Weakest Link Model

A chain-model system works like a chain. A chain is not stronger than its weakest link.

The series chain model is a series system in that if anyone component fails the system will fail; however, the concept of how a component fails is different. As an example of this concept of failure, consider a circuit composed of  $n$  identical components, and this circuit is subjected to thermal stresses. Let us assume for simplicity that the thermal stresses are the main cause of failure. In this situation the one component having the least resistance to the thermal stresses will be the first to fail. Then, in this case, the system reliability will be (K&L page 214):

$$R_{sys} = \min(R_1, R_2, \dots, R_n) \quad (7-5)$$

where  $R_j$  is the reliability of the  $j^{\text{th}}$  component and describes the component's resistance to failure from thermal stresses.

### Calculation of a component reliability ( $R_j$ )

If the strength of a component and the stress applied to the system are random variables denoted by  $\delta, S$  the chain will break if the applied stress exceeds the strength of anyone link. Hence to compute the component reliability, their joint density function should be integrated over  $\delta > s$  (see Fig 7.1):

$$R_i = \Pr(\delta > s) = \iint_{\delta > s} f_{\delta, s}(\delta, s) d\delta ds \quad (7-6)$$

With the assumption that  $\delta$  and  $s$  are independent:



$$R_i = \int_{s=0}^{\infty} f_s(s) \left[ \int_{\delta=s}^{\infty} f_{\delta}(\delta) d\delta \right] ds = \int_0^{\infty} f_s(s) [1 - F_{\delta}(s)] ds \quad (7-7)$$

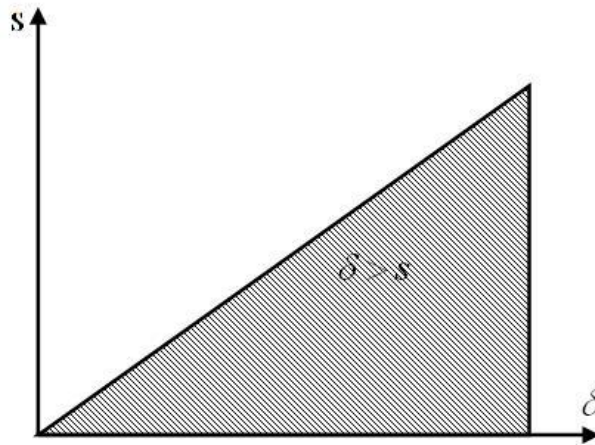

Fig 7-1 The region where the strength is more than stress

Let  $\delta_C$  be the random variable representing the strength of the  $n$ -link chain. This will be:

$$\delta_C = \min_{i=0}^n \delta_i$$

where  $\delta_i$  is the strength of the  $i^{\text{th}}$  link.

According to Eq. 1-42 in Sec. 1-12 on the minimum of a random sample of size  $n$  from a continuous distribution  $F_x(a)$ , if  $X_{(1)}$  denotes the minimum we have:

$$F_{X_{(1)}}(y) = 1 - [1 - F_x(y)]^n \quad (7-8)$$

In the above chain model if the cumulative distribution function (CDF) of the strength of each the  $n$  links is  $F_{\delta}(y)$ , then the CDF of the chain strength,  $G(y)$ , equals:

$$G(y) = F_{\delta(1)}(y) = 1 - [1 - F_{\delta}(y)]^n$$

Where

$F_{\delta}(y)$  is the CDF of each link of the chain

$F_{\delta(1)}(y)$  is the CDF of the strength of the weakest link.

On the other hand according to the concept of Eq. 7-7 i.e.

$R_i = \int_0^{\infty} f_s(s) [1 - F_{\delta}(s)] ds$  and the equation

$1 - F_{\delta_c}(y) = 1 - \{1 - [1 - F_{\delta}(y)]^n\}$  we could conclude that the reliability

of the  $n$ -link chain which equals  $R_c = P_r(\delta > s)$  is obtainable from:

$$R_c = \int_0^{\infty} f_s(s) [1 - F_{\delta}(s)]^n ds \quad (7-9)$$

Where

$R_c$  The reliability of an  $n$ -link chain

$F_{\delta}(y)$  The CDF of the strength of an individual component.

$f_s(s)$  The pdf of the stress acting on the system

Note the similarity of Eq. 7-7 with Eq. 7-9 for  $n=1$ .

### Example 7-2

A system is exposed to heat stress whose value is exponentially distribute with mean 500 °C. The system is a 10-link series chain. The strength of each link is exponentially distributed with mean 600 °C. Find the reliability of the chain.

### Solution

The probability density function(pdf) of the strength of each link:

$$f_{\delta_{part}}(t) = \frac{1}{600} e^{-\frac{t}{600}}, F_{\delta_{part}}(t) = 1 - e^{-\frac{t}{600}},$$

The pdf of the stress applied to the system is  $f_s = \frac{1}{500} e^{-\frac{s}{500}}$

According to Eq. 7-9:

$$R_{sys} = \int_0^{\infty} f_s(s) [1 - F_{\delta_{part}}(s)]^n ds \quad n = 10$$

$$R_{sys} = \int_0^{\infty} \frac{1}{500} e^{-\frac{s}{500}} \left[ e^{-\frac{s}{600}} \right]^{10} ds \Rightarrow$$

$$R_{sys} = \frac{1}{500} \int_{s=0}^{\infty} e^{-\frac{56s}{3000}} ds = \frac{1}{500} \times \frac{3000}{56} = \frac{6}{56}$$

End of Example ▲

It is worth mentioning that in this chapter the subsystems (components ) of a system are assumed to be independent of each other unless specified something else.

### **7-1-3 Parallel systems**

A parallel system is one that will fail only if all of its subsystems fail. Three models related to this kind is studied here: active parallel redundant, standby parallel redundant and shared load parallel.

#### **Definition of Redundancy**

In reliability engineering, redundancy may be defined as the duplication of the components of a system with the intention of increasing reliability of the system and an alternative to failing condition. Two types of commonly applied redundancy are active redundancy and standby redundancy.

#### **Active((Hot) Redundancy Definition**

Active redundancy does not require the external components or devices to perform the function of detection, decision and switching when an element or path in the redundant structure fails(Based on Li,2016). The redundant elements are always in operation to share the load of the system. This redundancy is also called hot redundancy(Shooma,2002 page 336)

#### **Standby Redundancy Definition**

Standby redundancy is defined as the redundancy that requires the external elements or devices to detect, make a decision and switch to another element or path as a replacement

for a failed element or path(Li,2016). In this type extra units are not brought into use until the main unit fails. It is the primary consideration in determining whether cold, warm or hot standby is to be used(Lewis, 1994, p263).

**Definition of cold & warm standby redundancy<sup>1</sup>:**

In cold standby the secondary unit is under no stress.

In warm standby the secondary unit is under a stress less than that of the main unit and more than that of cold standby.

It is worth mentioning that if nothing is said about the coldness or warmness of the standby components in this book, they are assumed cold.

**7-1-3-1 Reliability in active redundancy**

In a parallel system with active redundant, all subsystems are working and if the components are independent, its reliability is derived from:

$$R_{sys}(t) = 1 - [1 - R_1(t)][1 - R_2(t)] \dots [1 - R_n(t)] \quad (7-10)$$

**Proof**

Let  $X_s$  denote the lifetime of the system, and  $X_i$ ,  $i=1,..n$  denote the lifetime of the subsystems. Then in an active redundant system:

---

<sup>1</sup> From: , Lewis(1994) page 263, Grosh(1989)page169,Li(2016)and <https://www.weibull.com/hotwire/issue21/>

$$Pr(X_s \leq t) = Pr[\max(X_1, \dots, X_n) \leq t] = Pr(X_1 \leq t, \dots, X_n \leq t)$$

Assuming  $X_i, i=1, \dots, n$  are independent:

$$\begin{aligned} Pr(X_1 \leq t, \dots, X_n \leq t) &= Pr(X_1 \leq t) \dots Pr(X_n \leq t) \\ Pr(X_s \leq t) &= Pr(X_1 \leq t) \dots Pr(X_n \leq t) \\ \Rightarrow \\ 1 - R_{sys}(t) &= [1 - R_1(t)][1 - R_2(t)] \dots [1 - R_n(t)] \Rightarrow \\ R_{sys}(t) &= 1 - [1 - R_1(t)][1 - R_2(t)] \dots [1 - R_n(t)] \end{aligned}$$

### 7-1-3-2 Reliability and MTBF in active system with exponentially-distributed-lifetime components

In an active parallel system whose components failure rates  $\lambda_i, i = 1, \dots, n$  are constant (or the lifetimes are exponentially distributed), the reliability of each component is calculated from  $R_i(t) = e^{-t\lambda_i}, t \geq 0$ , and the system reliability is calculated from

$$R_{sys}(t) = 1 - \prod_{i=1}^n (1 - e^{-t\lambda_i}) \quad t \geq 0 \quad (7-11)$$

The Proof is similar to that of Eq. 3-2.

Note that Eq. 7.11 implicitly shows that the lifetime of active systems is not exponentially distributed.

### Two- component active parallel system

For  $n=2$  from Eq. 7-10 we could write:

$$R_{sys}(t) = 1 - (1 - R_1(t))(1 - R_2(t)) \text{ or}$$

$$R_{sys}(t) = R_1(t) + R_2(t) - R_1(t)R_2(t)$$

If the failure rate of the components are constants  $\lambda_1, \lambda_2$  then from

Eq. 7-11:

$$R_{sys}(t) = 1 - (1 - e^{-t\lambda_1})(1 - e^{-t\lambda_2}) = e^{-\lambda_1 t} + e^{-\lambda_2 t} - e^{-t(\lambda_1 + \lambda_2)} \quad t \geq 0 \quad (7-12-1)$$

If  $\lambda_1, \lambda_2$  are equal ( $\lambda_1 = \lambda_2 = \lambda$ ) then:

$$R_{sys}(t) = 2e^{-\lambda t} - e^{-2\lambda t} = 1 - (1 - e^{-\lambda t})^2 \quad (7-12-2)$$

The system mean life is:

$$(MTBF)_{sys} = \int_0^{\infty} R_{sys}(t) dt = \frac{1}{\lambda_1} + \frac{1}{\lambda_2} - \frac{1}{\lambda_1 + \lambda_2} \quad (7-13)$$

### Three-component active parallel system

For n=3 from from Eq. 7-10

$$R_{sys}(t) = 1 - (1 - R_1(t))(1 - R_2(t))(1 - R_3(t))$$

If the failure rate of the components are constants  $\lambda_1, \lambda_2, \lambda_3$

then

$$R_{sys}(t) = 1 - (1 - e^{-t\lambda_1})(1 - e^{-t\lambda_2})(1 - e^{-t\lambda_3}) \quad (7 - 14 - 1)$$

and the system mean life is:

$$MTBF_{sys} = \int_0^{\infty} R_{sys}(t) dt = \frac{1}{\lambda_1} + \frac{1}{\lambda_2} + \frac{1}{\lambda_3} - \frac{1}{\lambda_1 + \lambda_2} - \frac{1}{\lambda_1 + \lambda_3} - \frac{1}{\lambda_2 + \lambda_3} + \frac{1}{\lambda_1 + \lambda_2 + \lambda_3} \quad (7 - 14 - 2)$$

**Mean lifetime and reliability for active parallel systems having components with constant failure rate  $\lambda$**

If all  $n$  components of an active parallel system are independent and their lifetimes are exponentially distributed with parameter  $\lambda$  and mean lifetime  $\theta$  then (based on Garosh, 1989 page 135):

$$MTBF_{SysActive} = \theta \sum_{k=1}^n \frac{1}{k} \quad (7-15)$$

Table 7-1 gives the values of  $\sum_{k=1}^n \frac{1}{k} = M_n$ .

Eq. 7-15 could be verified for  $n=2$  from Eq. 7-13:

$$n=2 \quad MTBF_{sys} = \frac{1}{\lambda} + \frac{1}{\lambda} - \frac{1}{2\lambda} = \frac{3}{2\lambda} = \frac{3}{2}\theta$$

and for  $n=3$  from Eq. 7 - 14 - 2:

$$n=3 \quad MTBF_{sys} = \frac{3}{\lambda} - 3 \times \frac{1}{2\lambda} + \frac{1}{3\lambda} = \frac{11}{6\lambda} = \frac{11}{6}\theta.$$



The reliability of the above  $n$ -components active parallel system is:

$$R_{sys}(t) = 1 - (1 - e^{-\lambda t})^n \quad (7-16)$$

**Table 7-1** Values of  $M_n = \sum_{k=1}^n \frac{1}{k}$  for  $n=1, \dots, 32$  (Grosh, 1989 p136)

n	$M_n$	n	$M_n$
1	1	17	3.4295
2	1.5	18	3.4951
3	1.8333	19	3.5477
4	2.0833	20	3.5877
5	2.2833	21	3.6453
6	2.4500	22	3.7343
7	2.5928	23	3.7343
8	2.7178	24	3.7759
9	2.9289	25	3.8159
10	2.9289	26	3.8544
11	3.0198	27	3.8914
12	3.1032	28	3.9271
13	3.1801	29	3.9616
14	3.2515	30	3.9950
15	3.3182	31	4.0272
16	3.3807	32	4.0585

It is seen from Table 7-1 that "for a system to have double the mean life of a single component, it must consist of 4 components. To triple the mean life the system must have 11 components. Theoretically, there is no limit to how much the system mean life can be extended but the cost of extending life through mere redundancy is usually prohibitive. Redesign should be performed to excessive redundancy" (Grosh, 1989 p 135).

Given the reliability function of an active parallel system,  $R_{active}(t)$ , the failure rate function is obtained from:

$$h_{active}(t) = - \frac{\frac{d}{dt} R_{active}(t)}{R_{active}(t)} \quad (7-17)$$

### 7-1-3-3 Reliability of standby parallel system

Consider the standby parallel system shown in Fig 7.2. In the n-unit system only one unit works and when it fails the one of the n-1 standby units replaces it by the help of a switch. Upon failure, this active unit is replaced with another standby unit. The process continues until no more standby redundant units is available.

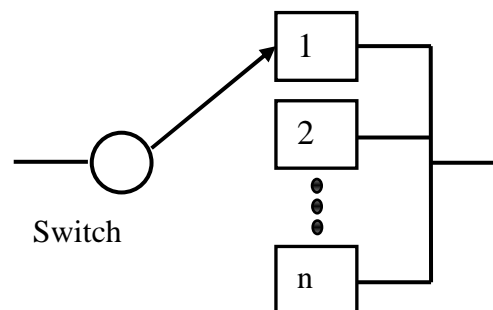

Fig. 7,2 A standby parallel system

The switch could be an operator or a device such as a hydraulic valve or electric relay or a contractor. Let the probability of successful operation of the switch for replacing the unit be denoted by  $P_s$ . If  $P_s$  is 1 the case is called perfect switching; if less than one, the case is called imperfect switching.

### Case 1: Perfect switching

"Perfect switching means perfectness of a detection and switching mechanism used to detect failure of a component and to activate a redundant component"<sup>1</sup>. In other word

Perfect switching is a situation where the reliability of the switch when needed to perform its function is 100% ( $P_s=1$ ) i.e. no failure is assumed for the switch when needed to perform its task. Below the reliability of systems having one active unit and  $n-1$  standby redundant (backup) units are analyzed.

### **Perfect switch :Two-component parallel system with an active unit and a standby redundant unit**

Consider a system with one active subsystem(unit) and one standby (backup) unit which replaces the active upon failure by the help of a switch of 100% reliability ( $P_s=1$ ). The reliability of this system is(K&L page 219):

$$\begin{aligned} R_{standby}^2(t) &= R_1(t) - \int_0^t R_2(t-t') \left[ \frac{d}{dt'} R_1(t') \right] dt' = \\ &= R_1(t) + \int_0^t R_2(t-t') f_1(t') dt' \end{aligned} \quad (7-18)$$

Where

$R_{standby}^2(t)$  Reliability function of a system having one active unit and  $n-1$  standby redundant units.

---

<sup>1</sup> Pradip Kundu & Asok Nanda, Redundancy Allocation in a System: A Brief Review

$R_1(t)$	Reliability function of the main unit
$R_2(t)$	Reliability function of the redundant unit
$f_1(t)$	Pdf of the main unit

For proof, interested readers could refer to Lewis(1994) page 255 or K&L page 219.

### Example 7-3-1

A system has one active unit with failure rate  $\lambda_1 = \frac{1}{25}$  and one standby redundant unit with failure rate  $\lambda_2 = \frac{1}{10}$ . When the active unit fails a perfect switch replaces it with the other unit. Calculate the reliability of the system.

### Solution

The constant failure implies that the life time is exponentially distributed ; then  $R_1(t)=e^{-\lambda_1 t}$ ,  $R_2(t)=e^{-\lambda_2 t}$ . According to Eq. 7-18:

$$\begin{aligned}
 R_{\text{standby}}^2(t) &= R_1(t) - \int_0^t R_2(t-t') \left[ \frac{d}{dt'} R_1(t') \right] dt' = \\
 &= e^{-\lambda_1 t} - \int_0^t e^{-\lambda_2(t-t')} \left[ \frac{d}{dt'} e^{-\lambda_1 t'} \right] dt' = \\
 &= e^{-\lambda_1 t} + \int_0^t e^{-\lambda_2(t-t')} \left[ \lambda_1 e^{-\lambda_1 t'} \right] dt' = e^{-\lambda_1 t} + \lambda_1 e^{-\lambda_2 t} \int_0^t e^{(\lambda_2 - \lambda_1)t'} dt' \Rightarrow \\
 R_{\text{standby}}^2(t) &= e^{-\lambda_1 t} + \lambda_1 e^{-\lambda_2 t} \frac{1}{\lambda_2 - \lambda_1} (e^{(\lambda_2 - \lambda_1)t} - 1)
 \end{aligned}$$

$$\lambda_1 = \frac{1}{25} \quad \lambda_2 = \frac{1}{10}$$

$$R_{\text{standby}}^2(20) = \exp(-20/10) + (1/10) * \exp(-20/25) * (\exp(20/(1/25 - 1/10)) - 1) / (1/25 - 1/10) = 0.8842$$

End of Example ▲

### Perfect Switch : Two-component parallel system with identical active and standby units (failure rate = $\lambda$ )

Assume that the main and standby units are identical, each with a constant failure rate  $\lambda$  and the switch is perfect. Then:

$$R_{\text{Sys}}^2(t) = e^{-\lambda t} (1 + \lambda t) \quad t \geq 0 \quad (7-19)$$

#### Proof

Since  $R_1(t) = R_2(t) = e^{-\lambda t}$  then according to Eq. 7-18:

$$\begin{aligned} R_{\text{standby}}^2(t) &= R_1(t) - \int_0^t R_2(t-t') \left[ \frac{d}{dt'} R_1(t') \right] dt' = \\ &= e^{-\lambda t} - \int_0^t e^{-\lambda(t-t')} [-\lambda e^{-\lambda t'}] dt' = e^{-\lambda t} + \lambda t e^{-\lambda t} = e^{-\lambda t} (1 + \lambda t) \end{aligned}$$

End of Proof . ■

#### Example 7-3-2

Calculate and compare the reliability of two configurations of a two-unit system (active parallel and standby parallel). The failure rate of the unit is 5%.

#### Solution

Since the components failure rate is constant, the lifetime is exponentially distributed. The reliability for standby configuration is calculated from Eq.7-19.

$$R_{\text{standby}}^2(t) = e^{-\lambda t} (1 + \lambda t) \quad t \geq 0$$

The reliability for active configuration is calculated from Eq.7-19.

$$R_{\text{sys}}(t) = 1 - \prod_{i=1}^2 (1 - e^{-t\lambda_i}) \quad t \geq 0 \quad \lambda_1 = \lambda_2 = \lambda$$

Then for  $t = 10$ ,  $\lambda = \frac{5}{100}$

$$R_{\text{standby}}^2 = 91\%, \quad R_{\text{active}}^2 = 84.5\%$$

for  $t = 100$ ,  $\lambda = \frac{5}{100}$ ,  $R_{\text{standby}}^2 = 4\%$ ,  $R_{\text{active}}^2 = 1.3\%$  ▲

### Perfect Switch: Three-unit standby system (1 active & 2 standby)

For the reliability of a three-unit standby system the following relationship holds (K&L p 220)

$$R_{\text{standby}}^3(t) = R_{\text{standby}}^2(t) + \int_0^t f_1(t_1) \int_0^{t-t_1} f_2(t_2) R_3(t-t_1-t_2) dt_2 dt_1 \quad (7-20)$$

where

$R_{\text{standby}}^3$  The reliability of 3-unit standby system

$R_{\text{standby}}^2$  The reliability of 2-unit standby system

$f_1$  The density function of active unit

$f_2$  The density function of standby unit No. 1

$R_3(t)$  The density function of standby unit No. 2

If the 3 units are identical and their lifetime is exponentially distributed with parameter  $\lambda$  then:

$$R_{\text{sys}}^3(t) = e^{-\lambda t} \left[ 1 + \lambda t + \frac{(\lambda t)^2}{2} \right] \quad t \geq 0 \quad (7-21)$$

#### Example 7-4

The reliability of the water supply system of a city is a concern of the city council. The council would like to ensure the inhabitants that the system will work for 20 years with a reliability of 95%. At the time being the water is supplied by a reservoir and a river (with mean lifetime of 25 and 10 years respectively) in parallel. The water is then disinfected in a building that has an active unit for disinfection and 2 standby backup units. Each of the disinfection units is designed for a useful life of 25 years. After disinfection the water goes to distribution subsystem, which is 99% reliable. The council is to decide whether to allow the municipality to add a deep well to

the water supply subsystem or not? What do you suggest?. Assume all life times are exponentially distributed.

### Solution

The RBD of the system of the Problem is as follows:

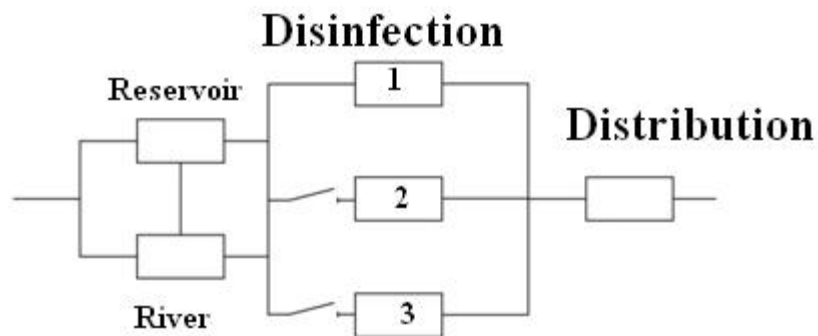

Fig 7.3 The RBD of the water supply system of Example 7-4

$$\text{Data: } t = 20, \lambda_{\text{Reservoir}} = \frac{1}{25}, \lambda_{\text{Disinfection}} = \frac{1}{25}$$

$$\lambda_{\text{river}} = \frac{1}{10}, R_{\text{Distribution Unit}} = 0.99$$

The reliability of the first subsystem (reservoir+ river) is calculated from Eq.7-10, assuming the reservoir and the river are both active:

$$\begin{aligned} R(20) &= 1 - (1 - e^{-\frac{20}{25}})(1 - e^{-\frac{20}{10}}) \\ &= 1 - (1 - 0.4493)(1 - 0.13532) = 0.5238 \end{aligned}$$

The 20-year reliability of the second subsystem (disinfection unit) is calculated from Eq. 7-21:



$$R(t) = e^{-\lambda t} \left[ 1 + \lambda t + \frac{(\lambda t)^2}{2} \right] \quad R(20) = e^{-\frac{20}{25}} \left( 1 + \frac{20}{25} + \frac{20^2}{2 \cdot 25^2} \right) = 0.932$$

The entire system reliability is currently:

$$R_{sys} = 0.5238 * .932 * .99 = 0.4833$$

Suppose the permission for a well of reliability of R' is issued by the council; then the system reliability would be:

$$R_{sys} = [1 - (1 - 0.4493)(1 - 0.13532)(1 - R')] * 0.932 * .99$$

It is evident that if even if R' has its greatest value i.e. 1 the system will have a reliability of  $[1 - (0)] * 0.932 * .99 = 0.9227$ .

The council cannot issue the permission because it is interested in 95% reliability. End of Example ▲

#### **Perfect Switch: n-unit standby system (1 active & n-1 standby)**

Consider an n-component system has 1 active unit and n-1 standby units whose lifetimes are exponentially distributed with parameter  $\lambda$ . If the switch is 100% perfect then (O'Connor 2003 page 167, K&L page 221):

$$R_{standby}^n(t) = e^{-\lambda t} \left[ \frac{\sum_{i=0}^{n-1} (\lambda t)^i}{i!} \right] \quad (7-22)$$

$$h_{standby}^n(t) = \frac{-R_{standby}^n{}'(t)}{R_{standby}^n(t)} \quad (7-23)$$

### Comparison of Two 2-component parallel configurations (active and standby)

Figure 7.4 shows "both the reliability and the failure rate for [2-component] active and standby parallel systems, along with the results for a system consisting of a single unit with the assumption that the lifetimes are exponentially distributed. At intermediate times the failure rate for the standby system is smaller than for the active parallel system. This is reflected in a larger reliability for the standby system(Lewis,1994 page 256).

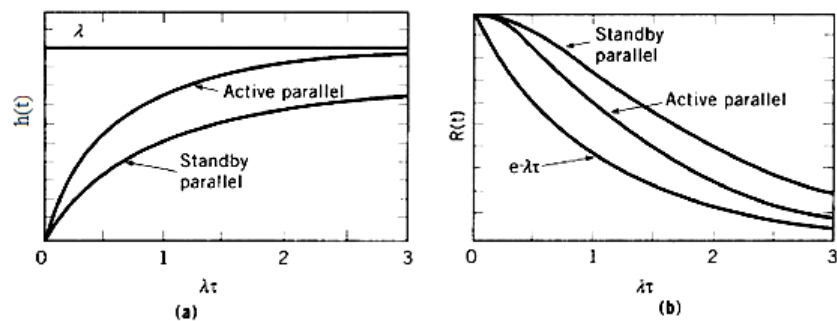

Fig 7-4 Properties of two-unit parallel systems(Lewis, 1994 page 256):  
 a) instantaneous failure rate      b) Reliability function

### Failure rate and mean lifetime of active & standby parallel systems having similar components

In this section active and standby configurations of a parallel system having similar subsystems are considered and their mean lifetime and reliability functions are mentioned.

## 2-&3-component active and perfect switch standby systems

### Failure rate function of 2-component systems:

a) The instantaneous failure rate function of an active parallel whose **two active** components have exponentially-distributed life is given by:

$$h_{active}(t) = -\frac{1}{R_{active}(t)} \frac{dR_{active}(t)}{dt} \Rightarrow$$

$$h_{active}(t) = \lambda \left( \frac{1 - e^{-\lambda t}}{1 - 0.5e^{-\lambda t}} \right) \quad (7-24)$$

b) The instantaneous failure rate function of a parallel system with **1 active and 1 standby** component and a perfect switch whose 2 components have exponentially-distributed lifetime is:

$$h_{standby}(t) = -\frac{1}{R_{stand}(t)} \frac{dR_{stand}(t)}{dt} \Rightarrow$$

$$h_{standby}(t) = \lambda \left( \frac{\lambda t}{1 + \lambda t} \right) \quad (7-25)$$

### Mean lifetime of 2-component system

The mean time to failure (MTTF) of a system could be calculated from integrating its reliability function over  $(0 \infty)$ :

$$MTTF = \int_0^{\infty} R(t) dt . \quad (7-26)$$

If the mean lifetime of a component ( $MTTF_{part}$ ) is given. The mean lifetime of an active parallel 2-component system is:

$$MTTF_{active} = \frac{3}{2} MTTF_{part} \quad (7-27-1)$$

And that of a standby parallel 2-component system is:

$$MTTF_{standby} = 2MTTF_{part} \quad (7-27-2)$$

### Mean lifetime of 3-component standby system

Given the lifetime of each component,  $MTTF_{part}$ , in a 3-component standby system whose switch is perfect i.e.  $P_s=1$  and has 1 active and 2 standby independent components, the system mean lifetime is given by:

$$MTTF_{standby} = 3MTTF_{part} \quad (7-27-3)$$

### Mean lifetime of n-component standby system-perfect switch

Given the lifetime of each component,  $MTTF_{part}$ , in an n-component standby system whose switch is perfect i.e.  $P_s=1$  and has 1 active and n-1 standby independent exponential-lifetime components, the system mean lifetime is given by:

$$MTBF_{standby} = \frac{n}{\lambda} = n \times MTBF_{part} \quad (7-27-4)$$

Where  $\lambda$  is the parameter of the exponential distribution of the lifetime of each component .

### Proof

The lifetime( $X$ ) of a system having 1 active unit,  $n-1$  redundant standby components and a perfect switch is the sum of the lifetimes( $X_i$   $i=1, \dots, n$ ) of its components:

$$X_{\text{standby}} = \sum_{i=1}^n X_i \rightarrow E(X_{\text{standby}}) = E(\sum X_i) = \sum_{i=1}^n E(X_i) = \sum MTBF_i$$

$$E(X_{\text{standby}}) = E(\sum X_i) = \sum_{i=1}^n E(X_i) = \sum MTBF_i$$

If  $X_i$  is exponentially distributed with parameter  $\lambda_i$  then:

$$MTBF_{\text{sys}} = \sum \frac{1}{\lambda_i} \quad (7-27-5)$$

If  $\lambda_1 = \dots = \lambda_n = \lambda$  then  $MTBF_{\text{standby}} = \frac{n}{\lambda} = n \times MTBF_{\text{part}}$  and the proof is complete. ■

### Example 7-5

A system has 1 active unit , 1 cold standby unit and a perfect switch. The failure rate of both units is 1 failures per 1000 hours. Calculate 100-hr reliability of the system.

### Solution

$t=100$ ,  $\lambda=0.001$ , according to Eq. 7-19

$$R_{\text{standby}}^2(t) = e^{-\lambda t} (1 + \lambda t) = 0.99532$$

Notice that if both units were active the according to Eq. 7-10:

$$R_{\text{active}}^2(100) = 1 - (1 - e^{-\lambda t})^2 = 0.9909 \quad \blacktriangle$$

## Reliability function and lifetime pdf of n-component standby system-Perfect switch

This section deals with the probability density function of the life time and the reliability function of a system having 1 active unit and n-1 cold standby units.

### Life pdf & reliability for Perfect switch: 2-component standby system

A single unit is put in service. A perfect switch replaces it by a cold backup unit as soon as a failure occurs. The density function of the lifetime of this system is derived from the following convolution (Grosh, 1989 p164):

$$f_{\text{sys}}(t) = \int_{z=0}^t f_1(z) f_2(t-z) dz \quad (7-28).$$

where

- $f_{sys}$  The pdf of system lifetime(T)  
 $f_1$  The pdf of the main device lifetime( $T_1$ )  
 $f_2$  The pdf of the backup lifetime( $T_2$ )

### Special case: Constant failure rate & perfect switch( $P_s = 1$ )

If both devices have constant failure rates  $\lambda_1, \lambda_2$  and  $P_s = 1$ , the lifetime pdf of the system is as follows:

$$f_{sys}(t) = \frac{\lambda_1 \lambda_2}{\lambda_1 - \lambda_2} (e^{-\lambda_2 t} - e^{-\lambda_1 t}) \quad (7-29)$$

**Proof**(Grosh, 1989, page166)

$$f_{sys}(t) = \int_{z=0}^t f_1(z) f_2(t-z) dz \Rightarrow$$

$$f_{sys}(t) = \int_0^t \lambda_1 e^{-\lambda_1 z} \lambda_2 e^{-\lambda_2(t-z)} dz = \lambda_1 \lambda_2 e^{-\lambda_2 t} \int_0^t e^{-(\lambda_1 - \lambda_2)z} dz$$

$$= \frac{\lambda_1 \lambda_2 e^{-\lambda_2 t}}{\lambda_1 - \lambda_2} [1 - e^{-(\lambda_1 - \lambda_2)t}] = \frac{\lambda_1 \lambda_2}{\lambda_1 - \lambda_2} e^{-\lambda_2 t} + \frac{\lambda_1 \lambda_2}{\lambda_2 - \lambda_1} e^{-\lambda_1 t} \Rightarrow$$

$$f_{sys}(t) = \frac{\lambda_1 \lambda_2}{\lambda_1 - \lambda_2} (e^{-\lambda_2 t} - e^{-\lambda_1 t}) \blacksquare$$

**The reliability function** in this case is(Grosh, 1989, p166):

$$R_{sys}(t) = \frac{\lambda_1 e^{-\lambda_1 t}}{\lambda_1 - \lambda_2} + \frac{\lambda_2 e^{-\lambda_2 t}}{\lambda_2 - \lambda_1} \quad (7-30)$$

**Proof:**

According to Eq. 7-18:

$$R_{sys}(t) = R_1(t) + \int_0^t R_2(t-t') [f_1(t')] dt' = e^{-\lambda_1 t} + \int_0^t e^{-\lambda_2(t-t')} [\lambda_1 e^{-\lambda_1 t'}] dt' \Rightarrow$$

$$R_{sys}(t) = \frac{\lambda_1 e^{-\lambda_2 t}}{\lambda_1 - \lambda_2} + \frac{\lambda_2 e^{-\lambda_1 t}}{\lambda_2 - \lambda_1}$$

Notice that for  $\lambda_1 = \lambda_2 = \lambda$  use Eq. 7-19 i.e.  $R_{sys}(t) = e^{-\lambda t} (1 + \lambda t)$  ■

### Life pdf & reliability for Perfect switch: 3-component standby system

A single unit is put in service. A perfect switch replaces it by a cold backup unit as soon as a failure occurs. When the backup fails, it is replaced by the other back. The density function of the lifetime of this system is derived from (Grosh, 1989 p165):

$$f_{sys}(t) = \int_{z=0}^t \int_{w=0}^z f_1(w) f_2(z-w) f_3(t-z) dw dz \quad (7-31)$$

The mean lifetime of this system and its reliability function is derived from :

$$R_{sys}(t) = \int_{x=t}^{\infty} f_{sys}(x) dx \quad (7-32)$$

$$MTTF_{sys} = \int_{x=0}^{\infty} x f_{sys}(x) dx = \int_0^{\infty} R_{sys}(t) dt \quad (7-33)$$

where

$f_{sys}$  The pdf of the system lifetime(T)



- $f_1$       The pdf of the main device lifetime( $T_1$ )  
 $f_2$       The pdf of the 1<sup>st</sup> backup lifetime( $T_2$ )  
 $f_3$       The pdf of the 2<sup>nd</sup> backup lifetime( $T_2$ )

In the above discussion it is assumed that the backup units are cold i.e. they are under no stress when they are in the standby mode.

In this three-components system if all units have the same constant failure rate  $\lambda$ , the reliability function is calculated from

$$\text{Eq. 7-21 i.e. } R_{\text{sys}}^3(t) = e^{-\lambda t} \left[ 1 + \lambda t + \frac{(\lambda t)^2}{2} \right].$$

### Reliability of n-component standby system :Perfect Switch

Consider a case where 1 unit is active, n-1 components are cold and in standby mode and the switch is 100% reliable. If the units have constant failure rates  $\lambda_1, \dots, \lambda_n$ , the reliability function of the system would be (Garosh, 1989 page 169):

$$R_{\text{sys}}^n(t) = \sum_{i=1}^n e^{-\lambda_i t} \prod_{\substack{j=1 \\ j \neq i}}^n \frac{\lambda_j}{\lambda_j - \lambda_i} \quad (7-34)$$

If  $\lambda_1 = \dots = \lambda_n = \lambda$  then (Grosh, 1989 p167):

$$R_{\text{sys}}^n(t) = e^{-\lambda t} + \lambda t e^{-\lambda t} + \dots + \frac{(\lambda t)^{n-1} e^{-\lambda t}}{(n-1)!} \quad (7-35)$$

Remember as proved earlier  $MTTF_{sys} = \sum_{i=1}^n MTTF_i = \sum_{i=1}^n \frac{1}{\lambda_i}$  gives

the system's mean time to failure and for  $\lambda_1 = \dots = \lambda_n = \lambda$

$$MTTF_{sys} = \frac{n}{\lambda}.$$

In the above discussions it is assumed that the backup units are cold i.e. they are under no stress when they are in the standby mode.

## Case 2: Imperfect switching

In this case the switch has a reliability of less than 1; i.e. failure of the detection and switching mechanism is probable and therefore the standby unit cannot replace the failed unit. Let  $P_s$  denotes the probability of failure of the detection and switching mechanism.  $P_s$  could be estimated as follows (Billinton & Allan, 1992)

$$\hat{P}_s = \frac{A}{B} \quad (7-36)$$

where

A = the number of times the switch works when required

B = the total number of times the switch is required to perform its function

## Imperfect switch ,2-component standby system: Reliability function and life time pdf

Let  $\overset{n}{R}_{sys}(t)$  denote the reliability function of a system having 1 active unit and n-1 redundant standby units with an imperfect switch ( $P_s < 1$ ).  $\overset{2}{R}_{sys}(t)$  is obtained from (K&L page 221):

$$\overset{2}{R}_{sys}(t) = R_1(t) + P_s \int_0^t f_1(t') R_2(t-t') dt' \quad (7-37)$$

where

$\overset{2}{R}_{sys}(t)$  Reliability function of 2-component standby system

$R_1(t)$  Reliability function of active unit

$R_2(t)$  Reliability function of standby unit

### Notice that

- Although it is probable the standby unit does not work when required to replace the active unit, this probability has not been taken into account.

- Substituting  $P_s = 1$  into Eq. 7-37 yields Eq. 7-18.

### 2-component standby , constant failure rate Imperfect switch with reliability $P_s$

Consider a system which has 1 active unit with constant failure rate  $\lambda_1$ , 1 redundant standby unit with constant failure rate  $\lambda_2$  and an imperfect switch having reliability  $P_s = 1 - p < 1$ .

$\overset{2}{R}_{sys}(t)$  is obtained from (Lewis, 1994 page 340, 341):

$$R_{sys}^2(t) = e^{-\lambda_1 t} + \frac{(1-p)\lambda_1}{\lambda_2 - \lambda_1} (e^{-\lambda_1 t} - e^{-\lambda_2 t}) \quad (7-38)$$

Let the units are similar i.e.  $\lambda_1 = \lambda_2 = \lambda$  then:

$$R_{sys}^2(t) = [1 + (1-p)\lambda t] e^{-\lambda t} = e^{-\lambda t} (1 + P_s \lambda t) \quad (7-39)$$

where

$p$  = the failure probability of the switch when required to perform its task

$$P_s = 1 - p = \text{Switch reliability}$$

## 2-component standby , constant failure rate

### Imperfect switch with reliability function $R_s(t)$

Consider a system which has 1 active unit with constant failure rate  $\lambda_1$ , 1 redundant standby unit with constant failure rate  $\lambda_2$  and an imperfect switch having reliability function

$R_s(t)$ . In this case  $R_{sys}^2(t)$  is obtained from (K&L page 222):

$$n=2 \quad R_{sys}^2(t) = R_1(t) + \int_0^t f_1(t') \times R_s(t') \times R_2(t-t') dt' \quad (7-40)$$

where

- $R_{sys}^2(t)$  Reliability function of 2-component standby system  
 $R_1(t)$  Reliability function of active unit  
 $R_2(t)$  Reliability function of standby unit  
 $R_s(t)$  Reliability function of switch  
 $f_1$  pdf of main unit lifetime( $T_1$ )

### Special case: Constant failure rates

Let failure rates of the active unit, the cold redundant standby unit and the switch is constant and equal  $\lambda_2, \lambda_1$  &  $\lambda_s$  then:

$$MTTF_{sys} = \int_0^t R_{sys}^2(t) dt = \frac{1}{\lambda_1} - \frac{\lambda_1}{(\lambda_1 - \lambda_2 + \lambda_s)(\lambda_1 + \lambda_s)} + \frac{\lambda_1}{(\lambda_1 - \lambda_2 + \lambda_s)\lambda_2}$$

or

$$MTTF_{sys} = \frac{1}{\lambda_1} + \frac{\lambda_1}{\lambda_1 - \lambda_2 + \lambda_s} \left( \frac{-1}{\lambda_1 + \lambda_s} + \frac{1}{\lambda_2} \right) \quad (7-41)$$

Furthermore if  $\lambda_1 = \lambda_2 = \lambda$  then :

$$MTTF_{sys-standby} = \frac{1}{\lambda} + \frac{\lambda}{\lambda - \lambda + \lambda_s} \left( \frac{-1}{\lambda + \lambda_s} + \frac{1}{\lambda} \right) \Rightarrow$$

For a system with 1 active , 1 standby unit and imperfect switch

$$MTTF_{sys-standby} = \frac{1}{\lambda} + \frac{1}{\lambda_s} - \frac{\lambda}{\lambda_s(\lambda + \lambda_s)} \quad (7-42)$$

where

$\lambda$  = the failure rate of both units

$\lambda_s$  =the failure rate of the switch

Eq. 7-40 for this case yields(K&L p222):

$$R_{sys}^2(t) = e^{-\lambda t} \left[ 1 + \frac{\lambda}{\lambda_s} \left( 1 - e^{-\lambda_s t} \right) \right] \quad t \geq 0 \quad (7-43)$$

The mean time to failure of is calculated as follows:

$$MTTF_{sys} = \int_0^{\infty} R_{sys}^2(t) dt = \int_0^{\infty} e^{-\lambda t} \left[ 1 + \frac{\lambda}{\lambda_s} \left( 1 - e^{-\lambda_s t} \right) \right] dt \Rightarrow$$

$$MTTF_{sys} = \frac{1}{\lambda} + \frac{1}{\lambda_s} - \frac{\lambda}{\lambda_s (\lambda_s + \lambda)} \quad \text{which is Eq.7-42.}$$

Using Eq. 7.39 for the reliability function of a 2-component system whose active and standby units have the same mean time to failure

$$MTTF_{part} = \frac{1}{\lambda} \quad \text{and the switch is imperfect with reliability } P_s :$$

$$MTTF_{sys} = \int_0^{\infty} R_{sys}^2(t) dt = \frac{1+P_s}{\lambda} = (1+P_s)MTTF_{part} \quad (7-45)$$

Notice:

-Substituting  $P_s = 1$  in the above relationships yields  $R_{sys}^2(t)$  and

$MTF_{sys}$  for perfect switching which we saw earlier.

-The reliability function of a two-component system having similar active and standby units with the same failure rate  $\lambda$  is :

Calculated from Eq. 7-43 i.e.  $R_{sys}^2(t) = e^{-\lambda t} \left[ 1 + \frac{\lambda}{\lambda_s} (1 - e^{-\lambda_s t}) \right]$  given

$\lambda_s$  as the switch failure rate

Or is calculated from Eq. 7-39 i.e.  $R_{sys}^2(t) = e^{-\lambda t} (1 + P_s \lambda t)$  if the reliability of the switch is given as a constant value  $P_s$ .

### Example 7-6<sup>1</sup>

A system is composed of 1 active unit A, 1 redundant standby unit B and a switch S. The lifetime of the units is exponentially distributed with 1 failure/1000hr. The key has a constant rate of failure per 10000 hours. Find 500-hr reliability of the system and its mean lifetime.

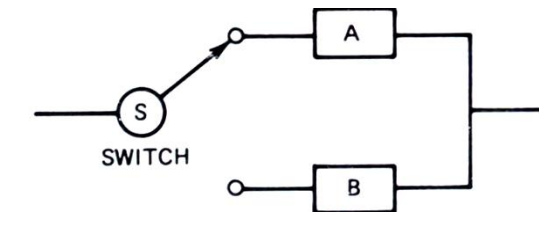

<sup>1</sup> From Dr Eshargh's pamphlet, Faculty member of Sharif University of Tech, Tehran. Figure from K & L p 59.

**Solution:**

Eq. 7-43 gives the reliability function:

$$\lambda = 10^{-3} \text{ failure/hr} = 1 \times 1000^{-1}, \lambda_s = 1 \times 10000^{-1} = 10^{-4}, t = 500$$

$$R_{sys}^2(t) = e^{-\lambda t} \left[ 1 + \frac{\lambda}{\lambda_s} \left( 1 - e^{-\lambda_s t} \right) \right] = 90.2\%$$

Eq. 7-44 gives the reliability function:

$$MTTF_{sys} = \frac{1}{\lambda} + \frac{1}{\lambda_s} - \frac{\lambda}{\lambda_s (\lambda_s + \lambda)} = 1909.9 \text{ hr End of Example } \blacktriangle$$

**Example 7-7** (Ebrahimi, 1992, p 267)

The failure rate of a device is constant and equal to 500 failures per 1 million hours ( $\lambda = 500 \times 10^{-6}$ ). To enhance the reliability another unit is used as standby redundant which replaces the device upon failure by switch having 97% reliability. Find 1000-hr reliability of this system. Solve the problem again for a perfect switch.

**Solution:**

Eq. 7-39 gives the reliability function. For  $P_S = 0.97$ :

$$R_{sys}^2(t) = e^{-\lambda t} (1 + P_S \times \lambda t)$$



$$R_{\text{sys}}^2(1000) = e^{-0.5}(1 + 0.97 \times 500 \times 10^{-6} \times 1000) = 0.9007$$

For  $P_s = 1$  from Eq. 7-19:

$$R_{\text{sys}}^2(1000) = e^{-\lambda t}(1 + \lambda t) = e^{-0.5}(1 + 0.5) = 0.9098$$

$\lambda t = 500 \times 10^{-6} \times 1000 = 0.5$  is the mean of the failures of each device per 1000 hours. End of Example ▲

### Comparison of reliability function of active and standby systems-imperfect switching

Eqs. 7-43 & 7-45 give the following 2 apparent different relationships for 2-component standby system-imperfect switch:

$$1) R_{\text{sys}}^2(t) = e^{-\lambda t} \left[ 1 + \frac{\lambda}{\lambda_s} \left( 1 - e^{-\lambda_s t} \right) \right] \quad t \geq 0$$

$$2) R_{\text{sys}}^2(t) = e^{-\lambda t} [1 + (1-p)\lambda t] = e^{-\lambda t} (1 + P_s \lambda t) \quad t \geq 0$$

if the failure rate of the switch ( $\lambda_s$ ) is given the former relationship is used, if the reliability of the switch ( $P_s$ ) is given the latter is used.

**Question:** Are these 2 relationship equivalent?

**Answer:** Suppose they are equal i.e.

$$e^{-\lambda t} \left[ 1 + \frac{\lambda}{\lambda_s} \left( 1 - e^{-\lambda_s t} \right) \right] = e^{-\lambda t} [1 + (1-p)\lambda t] = e^{-\lambda t} (1 + P_s \lambda t) \Rightarrow$$

$$P_s = \frac{1 - e^{-\lambda_s t}}{\lambda_s t}$$

This the switch average reliability. That is they would be equivalent if  $P_s$  is calculated as the average of its reliability function ( $e^{-\lambda_s t}$ ) of constant- failure- rate switch over period(0 t):

$$\text{switch average reliability} = P_s = \frac{\int_0^t e^{-\lambda_s t} dt}{t - 0} = \frac{1 - e^{-\lambda_s t}}{\lambda_s t} \quad (7-46)$$

## 2-component standby system with similar units, imperfect switch and warm redundant unit

Consider a system that has an active unit and a standby unit. both the main and the secondary units have the same failure rate  $\lambda$  but the secondary unit has  $\lambda^+$  as failure rate while is standby mode. The switch is imperfect with the failure probability  $p=1-P_s$ .

The expression for the reliability function of this system is (Lewis,1994 p262):

$$R_{sys}(t) = e^{-\lambda t} \left[ 1 + P_s \times \frac{\lambda}{\lambda^+} (1 - e^{-\lambda^+ t}) \right] \quad (7-47)$$

The system mean time to failures is calculated as follows:

$$MTTF_{sys} = \int_0^t R_{sys}(t) dt = \int_0^t e^{-\lambda t} \left[ 1 + (1-p) \frac{\lambda}{\lambda^+} (1 - e^{-t\lambda^+}) \right] dt \Rightarrow$$

$$MTTF_{sys} = \frac{1 + \frac{P_s}{1 + \frac{\lambda^+}{\lambda}}}{\lambda} = \frac{1 + \frac{1-p}{1 + \frac{\lambda^+}{\lambda}}}{\lambda} \quad (7-48)$$

Where

$p$  Switch failure probability

$P_s = 1 - p$  Switch reliability

$\lambda$  Failure rate of each unit while in active mode

$\lambda^+$  Failure rate of secondary unit while in standby mode

### Example 7-8

Consider a 2-component standby system in which the switch for replacing the units is imperfect and its lifetime is exponentially distributed. The main unit and the secondary units when becomes active fail at the constant rate of  $\lambda$ . We know that:

Given the failure rate of the switch ( $\lambda_s$ ), the reliability of the system is calculated from Eq. 7-43 i.e. (from: K&L p222):

$$R_{sys}^2(t) = e^{-\lambda t} \left[ 1 + \frac{\lambda}{\lambda_s} \left( 1 - e^{-\lambda_s t} \right) \right] \quad t \geq 0$$

If the failure rate of the secondary unit while in standby mode is  $\lambda^+$  then given the value  $P_s$  for the reliability of the switch, the reliability of the system is calculated from Eq. 7-47 i.e. (from: Lewis p262):

$$R_{sys}^2(t) = e^{-\lambda t} \left[ 1 + P_s \frac{\lambda}{\lambda^+} (1 - e^{-\lambda^+ t}) \right].$$

a) Specify a condition under which these two expressions identical if  $\lambda^+ = \lambda$ .

b) If in Example 7-7  $\lambda^+ = 500 \times 10^{-6}$  under which condition do the 2 relationship give the same result?

**Answer :a)**

Substituting  $\lambda^+ = \lambda$  in second relationship and equating the 2 expression we would have the following result:

$$P_s = \frac{1 - e^{-\lambda_s t}}{\lambda_s} \times \frac{\lambda}{1 - e^{-\lambda t}}$$

We the Taylor expansion of  $f(x)$  about a is:

$$f(x) = f(a) + \frac{1}{1!}(x-a)f'(a) + \frac{1}{2!}(x-a)^2 f''(a) + \dots$$

Therefore  $e^{-\lambda t}$  is expanded as follows:

$$e^{-\lambda t} = 1 + \frac{t-0}{1!}(-\lambda e^{-\lambda \times 0}) + \dots$$

Therefore  $e^{-\lambda t} \cong 1 - \lambda t$  or

$$1 - e^{-\lambda t} \cong \lambda t \quad (7-49)$$

Therefore we must have

$$P_s \cong \frac{1 - e^{-\lambda_s t}}{\lambda_s} \times \frac{\lambda}{\lambda t} = \frac{1 - e^{-\lambda_s t}}{\lambda_s t} = \frac{\int_0^t e^{-\lambda_s t} dt}{t}$$

That is under the condition that the value given for the switch reliability ( $P_s$ ) equals the mean of reliability function of exponential-distributed-lifetime switch over period (0 t) the 2 expression give the same results.

### Answer: b)

Since the specified  $\lambda^+$  equals  $\lambda$  in Example 7-7, therefore if

$$P_s = \frac{1 - e^{-\lambda_s t}}{\lambda_s t} \text{ or } 0.97 = \frac{1 - e^{-\lambda_s \times 1000}}{\lambda_s \times 1000} \text{ or } \lambda_s \cong 61 * 10^{-6} \text{ the 2 relationship}$$

give the same result.

End of Example ▲

Therefore the following expressions for the reliability of a two-component standby system ( imperfect switch warm standby )

$$R_{sys}^2(t) = e^{-\lambda t} \left[ 1 + (1-p) \frac{\lambda}{\lambda^+} (1 - e^{-\lambda^+ t}) \right]$$

$$R_{sys}^2 = e^{-\lambda t} \left[ 1 + \frac{\lambda}{\lambda_s} \left( 1 - e^{-\lambda_s t} \right) \right] \quad t \geq 0$$

$$R_{sys}^2(t) = e^{-\lambda t} [1 + (1-p)\lambda t] = e^{-\lambda t} (1 + P_s \lambda t) \quad t \geq 0$$

Give the same results if the failure rate of the redundant unit while in standby mode equals the failure rate of the active unit ( $\lambda^+ = \lambda$ ) and the given reliability value for the switch ( $P_s$ ) equals the value obtained from Eq. 7-46.

**Example 7-9** (Lewis, 1994 page 262)

An engineer designs a standby system with two identical units to have an idealized MTTF of 1000 days. To be conservative, she then assumes a switching failure probability of 10% ( $p=0.10$  or  $P_s=0.9$ ) and the failure rate of the unit in standby of 10% of the unit in operation i.e.  $\lambda^+ = 0.10\lambda$ . Assuming constant failure rates, estimate the reduced MTTF of the system with switching and standby failures included.

**Solution**

The system has  $n=2$  components (1 active 1 standby). Since the failure rate of each component is constant; therefore the distribution of the lifetime of the units are exponentially distributed.

Let  $\lambda =$  the constant failure rate of each unit in operation i.e. when is active. If the standby unit were cold, according to Eq. 7-27-4 for the idealized case:

$$MTTF_{sys} = 2 \times \frac{1}{\lambda} \Rightarrow 1000 = 2 \times \frac{1}{\lambda} \Rightarrow \lambda = 0.002 \text{ per day}.$$

In imperfect switching according to Eq. 7-48 with  $p = 0.1$  &  $\lambda^+ = 0.10\lambda$  :

$$MTTF_{sys} = \frac{1 + \frac{1-p}{1 + \frac{\lambda^+}{\lambda}}}{\lambda} = \frac{1 + \frac{1-0.1}{1+0.1}}{0.002} \cong 909 \text{ days}$$

End of Example ▲

The relationships for 3-component standby systems could be studied in K&L pages 221-222. The interested readers in the reliability function and the MTTF of the general case  $n=n$ , could refer to Niaki & Yaghoubi(2020).

#### 7-1-4 Shared load parallel configuration<sup>1</sup>

Up to now when analyzing redundancy, independence was assumed among the units within system. In other words, it was assumed that the failure of a unit does not affect the failure rates. In this section, the load-sharing systems are considered, where the assumption of independence is no longer valid. When units in a system fail one by one, the total load of the system is redistributed among the surviving units, resulting in an increased load shared by each surviving unit. For an example of load sharing consider a section of a machine which has several

---

<sup>1</sup> K&L page 222, Lewis(1996)page 260&chapter11

screws When a screw break, the total load is redistributed among the surviving screws.

Here analysis will be limited to the case of two units. In this load sharing case the reliability function of the system is(K&L p224):

$$R_{sys}(t) = [R_g(t)]^2 + 2 \int_0^t g(t_1) R_g(t_1) R_f(t-t_1) dt_1 \quad (7-50)$$

Where

$g(t)$  The pdf for TTF under half load

$f(t)$  The pdf for TTF under full load

$$R_g(t) = \int_t^\infty g(\tau) d\tau$$

$$R_f(t) = \int_t^\infty f(\tau) d\tau$$

For the proof refer to K&L page223.

For many probability density functions, calculation of Eq. 7-50 is difficult. As an easy example constant-rate-failure is considered.

**Special case:**

**2-component shared loading: constant failure rates**

Consider a load sharing system that has 2 identical components. The failure rate of each is constant  $\lambda_g$  when both units work. The failure rate increases to another constant  $\lambda_f$  when one unit fails. substituting  $g(t)=\lambda_g e^{-\lambda_g t}$ ,  $R_g(t)=e^{-\lambda_g t}$  and  $R_f(t)=e^{-\lambda_f t}$  in Eq. 7-50 gives the system reliability function for this case as follows(K&L page 224)



$$R_f(t) = e^{-\lambda_f t} \quad R_{sys}(t) = e^{-2\lambda_g t} + \frac{2\lambda_g}{2\lambda_g - \lambda_f} (e^{-\lambda_f t} - e^{-2\lambda_g t}) \quad (7-51)$$

Where

$\lambda_g$     Half load failure load  
 $\lambda_f$     Full load failure load

### Example 7-10

Consider a 2- component load sharing parallel configuration in which the failure rate is  $1 \times 10^{-3}$  per hour under partial load (half load here) and  $4 \times 10^{-3}$  under full load. Calculate 1000-hr reliability of the system.

### Solution

$$\lambda_g = 0.001 \text{ per hour}, \quad \lambda_f = 4 \times 10^{-3} \text{ per hour}$$

According to Eq.7-51:

$$R_{sys}(t) = e^{-2\lambda_g t} + \frac{2\lambda_g}{2\lambda_g - \lambda_f} (e^{-\lambda_f t} - e^{-2\lambda_g t})$$

$$R_{sys}(1000) =$$

$$e^{-2 \times 0.001 \times 1000} + \frac{2 \times 0.001}{2 \times 0.001 - 0.004} (e^{-0.004 \times 1000} - e^{-2 \times 0.001 \times 1000})$$

Using MATLAB

$$= \exp(-2*0.001*1000) + 2*0.001*(\exp(-0.004*1000) - \exp(-2*0.001*1000))/(2*0.001 - 0.004)$$

$$\Rightarrow R_{sys}(1000) = 25.24\% \quad \text{End of Example} \quad \blacktriangle$$

## 7-2 System Effectiveness Measures

Reliability is not the only index used to characterize the performance of an engineering system. Some other features are serviceability, maintainability, operational readiness and availability described below.

### Serviceability

Serviceability is the measure of the features that support the ease and speed of which corrective maintenance and preventive maintenance can be conducted on a system. In a simple statement we could say serviceability is used to present the degree of the difficulty with which equipment can be repaired. When it is said equipment 1 is more serviceable than equipment 2, it is meant that the better Serviceability the shorter the active repair time.

This index is difficult to measure on a ratio scale; however it can easily be measured on an is usually expressed as ranking.

Serviceability is difficult to measure on a ratio scale; however, it can easily be measured in ordinal scale by a specifically developed rating and/or ranking procedure, which requires that systems be compared and ranked according to the ease of serviceability (Handbook of industrial Eng'g edited by Gavriel Salvendy ).

## **Maintainability**

In MIL-STD-721C, *maintainability* is defined as follows:

The measure of the ability of an item to be retained in or restored to specified condition when maintenance is performed by personnel having specified skill levels, using prescribed procedures and resources, at each prescribed level of maintenance and repair(Ireson, et al, 1996 page 15-3)

While the reliability engineer is concerned with many physical characteristics that affect system components, such as temperature, humidity, shock, and vibration, the maintainability engineer will be concerned with the physical partitioning of a system into repairable items; the accessibility, weight, and volume of these items; the skills and training of maintenance crew; and the availability of the appropriate tools and equipment for conducting maintenance activities(Ireson, et al, 1996 page 15-3).

The maintainability index of a machine is the probability that it restores to working status within a specified period. Notice by the term "down time" used sometimes here it is meant all the time period the machine is out of service. This time period includes the time necessary to detect the failure, the repair time, administrative and logistic times.

## **Maintainability function**

Maintainability function for a device, denoted by  $M(t)$ , is the probability that the maintenance task considered will be successfully completed before a specified time  $t$ :

$$M(t) = \Pr(T_{\text{repair}} < t) \quad (7-52-1)$$

where random variable  $T_{\text{repair}}$  is

$T_{\text{repair}} =$  The time required for completing the service, maintenance, replacing new units...

If  $m(t)$  denotes the probability density function of  $T_{\text{repair}}$  then :

$$M(t) = \int_0^t m(x) dx \quad (7-52-2)$$

Therefore the maintainability function for a device, represents the probability that the device restores( gets out of down state) successfully within a specified time. It is worth noting that exponential, log-normal distribution Weibull are 3 distributions frequently used for service times.

### Example 7-11

The total service and maintenance time of a dive has the pdf  $m(t) = \gamma e^{-\gamma t}$ , find the maintainability function of the device.

### Solution

$$M(t) = 1 - e^{-\gamma t} = 1 - e^{-\frac{t}{\theta}} \quad \text{End of Example} \quad \blacktriangle$$

It is worth mentioning the term *dependability* has been introduced to cover all important aspects of a device to function satisfactorily including reliability, availability, maintainability, quality and safety. Interested readers could refer to references

such as Standards IEC 60050-192 & IEC 60300 , Eusgeld et al 2008) and Martha et al (2022)

### Mean time to repair(MTTR)

A widely used maintainability parameter is MTTR . For an n-component system it is calculated from(Ireson, et al. 1996 page 15-6):

$$MTTR = \frac{\sum_{i=1}^n \lambda_i (MTTR_i)}{\sum \lambda_i} = \sum_{i=1}^n \left( \frac{\lambda_i}{\sum \lambda_i} \right) (MTTR_i) \quad (7-53)$$

where

- $\lambda_i$  Failure rate of the  $i^{\text{th}}$  repairable component
- $MTTR_i$  Mean time to repair  $i^{\text{th}}$  repairable unit
- n number components in the system
- $\frac{\lambda_i}{\sum \lambda_i}$  A fraction of failures per unit time related to  $i^{\text{th}}$  unit

It might be useful for some readers to know that some references such as the manual of MIL-HDBK-472 standard deal with MTTR in details. This manual is comprehensive design tool for maintainability prediction analysis including calculating MTTR.

### Operational readiness(OR)

"The term *operational readiness*(O.R.) is defined as the probability that either a system is operating or can operate

satisfactorily when the system is used under stated conditions. Operational readiness is more encompassing than the term "availability" (K&L page 225).

3 time periods are used in the calculation of OR(K&L p 226):

$$\text{O.R.} = \frac{\text{operating time} + \text{idle time}}{\text{operating time} + \text{idle time} + \text{down time}} \quad (7-54)$$

### Example 7-12(K&L p226)

The following figure shows the status of a machine over a time horizon graphically. Suppose the total operating time of the machine is 8 time units, the idle time and the downtime is 6 time units each. Calculate the operational readiness of the machine

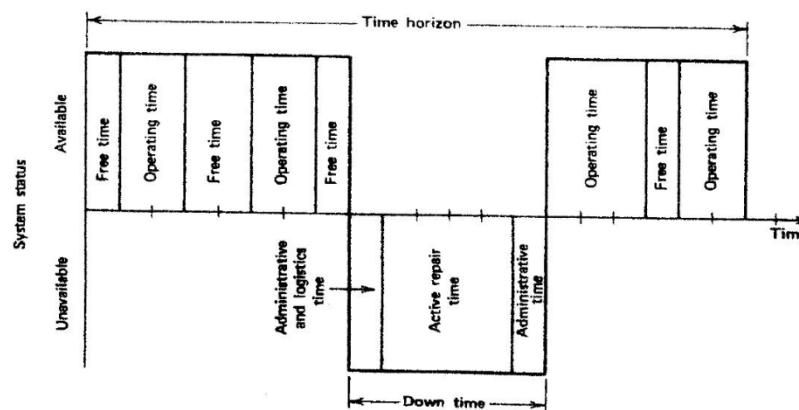

Fig 7-5 A Machine status over a time horizon(K&L p226)

### Solution

$$\text{OR} = \frac{\text{operating time} + \text{idle time}}{\text{operating time} + \text{idle time} + \text{down time}} = \frac{8+6}{8+6+6} = 0.70$$

This mean that the machine is ready to perform its function 70% of the time. End of Example ▲

### 7-3 Availability

Availability as a measure of system effectiveness is defined "as the probability that an item will be available when required, or the proportion of total time the item is available for use" (O'connor,2003 page 300). At first availability is studied for the case where different times(operating, down..) are fixed and not variable. Here availability is denoted by  $A$ . Availability which excludes free(idle) time would be estimated from(K&L page 227)

$$A = \frac{\text{operating time}}{\text{operating time} + \text{down time}} \quad (7-54-1)$$

#### 7-3-1 Intrinsic Availability

Intrinsic availability index( $A_I$ ) of a machine does not include administrative time and logistic time in the down time of the machine. In other words, it ignores administrative delays( such as the time it takes to find a repairman, spare components, tools...) and uses only operating time and actual repair time. Therefore  $A_I$  is computed from(K&L page 227):

$$A_I = \frac{\text{operating time}}{\text{operating time} + \text{a.r.t}} \quad (7-55)$$

where a.r.t. is the actual repair time shown in Fig 7-5.

**Example 7-12:**

The down time in one complete cycle of a machine is 6 time units and its operating time is 8 units(See Fig 7-5). Find the machine availability (A).

**Solution**

$$A = \frac{\text{operating time}}{\text{operating time} + \text{down time}} \Rightarrow A = \frac{8}{6+8} = 0.57 = 57\%$$

End of Example ▲

**Example 7-14** In Example 7-13 if the administrative time is one time unit, and the logistic time is also one time unit. Find the intrinsic availability.

**Solution**

$$A_I = \frac{\text{operating time}}{\text{operating time} + \text{a.r.t}}$$

a.r.t.= total down time- administrative & logistic times=6-2=4.

$$A_I = \frac{8}{8 + 4} = 0.69 = 66\%$$

Examples 7-13&14 show that by eliminating the administrative and logistics time in the repair cycle, the current availability of 0.57 can be increased in the limit to the intrinsic availability of 0.66. There is a potential for a 9% improvement in availability.

End of Example ▲

**7-3-2 Availability function**

The availability, like the reliability, is time dependent. The above relationships for availability give fixed values independent of time.



The reliability function for repairable systems,  $A(t)$ , is defined as the probability that the system operates at time  $t$  irrespective of its past history of breakdown and repair (Grosh, 1989 page 268).

Assuming specific models for both the failure and downtime (repair time) distributions, the maintainability and availability functions could be derived. Considering the simplest possible case (using the exponential distribution with parameters  $\lambda$  and  $\mu$  respectively for time to failure and repair time) yields a differential equation for availability function of this simple case

$$\text{(K\&L page 228): } \frac{dA(t)}{dt} = -(\lambda + \mu) \times A(t) + \mu$$

*The availability function for repairable systems -time to failure (TTF) and repair time :exponential*

The following solution of the above differential equation is the availability function for a system with exponentially distributed TTF and downtime (repair time) having parameters  $\lambda$  &  $\mu$  respectively (Grosh, 1989 p 270, K&L 280)

$$A(t) = \frac{\mu}{\mu + \lambda} + \frac{\lambda}{\lambda + \mu} e^{-(\lambda + \mu)t} \quad (7-56)$$

### 7-3-3 availability function for nonrepairable systems: exponential lifetime

For a system which is not repairable  $\mu = 0$ . If the lifetime of the system is exponentially distributed, from Eq. 7-56 it is concluded that its availability equals its reliability at time  $t$ :

$$\text{nonrepairable system} \quad A(t)=R(t) \quad (7-57)$$

### 7-3-4 Steady state availability

A fraction of the total time that the device is ready to perform its duty in the long range is called steady state availability denoted by  $A$ . If the operating time (TTF) of the machine is exponentially distributed with mean  $MTTF = \frac{1}{\lambda}$  and the down time has the mean  $MTTR = \frac{1}{\mu}$  as an index of maintainability, then (K&L page 228):

$$A = \lim_{t \rightarrow \infty} A(t) = \frac{\mu}{\mu + \lambda} \quad (7-58-1)$$

or

$$A = \frac{\frac{1}{\lambda}}{\frac{1}{\mu} + \frac{1}{\lambda}} \quad (7-58-2)$$

Needles to say that  $A$  has a value between 0 and 1. Notice that:

-If only the life time is in exponential form and the down time is not exponentially distributed, the relationship for the steady state availability is the same as Eq.7.58. and more generally

according to Ross(985) page 402 : If the on & off distributions are arbitrary continuous distributions with respective mean

$\frac{1}{\lambda}$  &  $\frac{1}{\mu}$  then it follows from the theory of alternating renewal process (see page 287 of Ross,1985) that  $A(t)$  in the long range approaches to  $A = \frac{\frac{1}{\lambda}}{\frac{1}{\mu} + \frac{1}{\lambda}}$ .

Therefore we could say if the operating time and the repair time have continuous probability distributions with mean MTBF and MTTR, the steady-state availability would be:

$$A = \frac{\text{MTBF}}{\text{MTBF} + \text{MTTR}} \quad (7-59-1)$$

Fig.6.7 shows a nomogram (abaque) for this relationship between availability and MTBF(a measure of reliability) and MTTR(a measure of maintainability). That is draw a line which connects the given MTBF on the MTBF scale and the given MTTR on the MTTR scale. The intersection of this line and A scale is value equal to what is resulted from Eq. 7-59.1.

It is reminded that

- if the life time and the repair time are not random variables use Eq. 7-54&55 for calculating availability.
- A device can have low availability, high reliability and vice versa.
- Index A could be used for comparing two types of a device that have the same reliability.

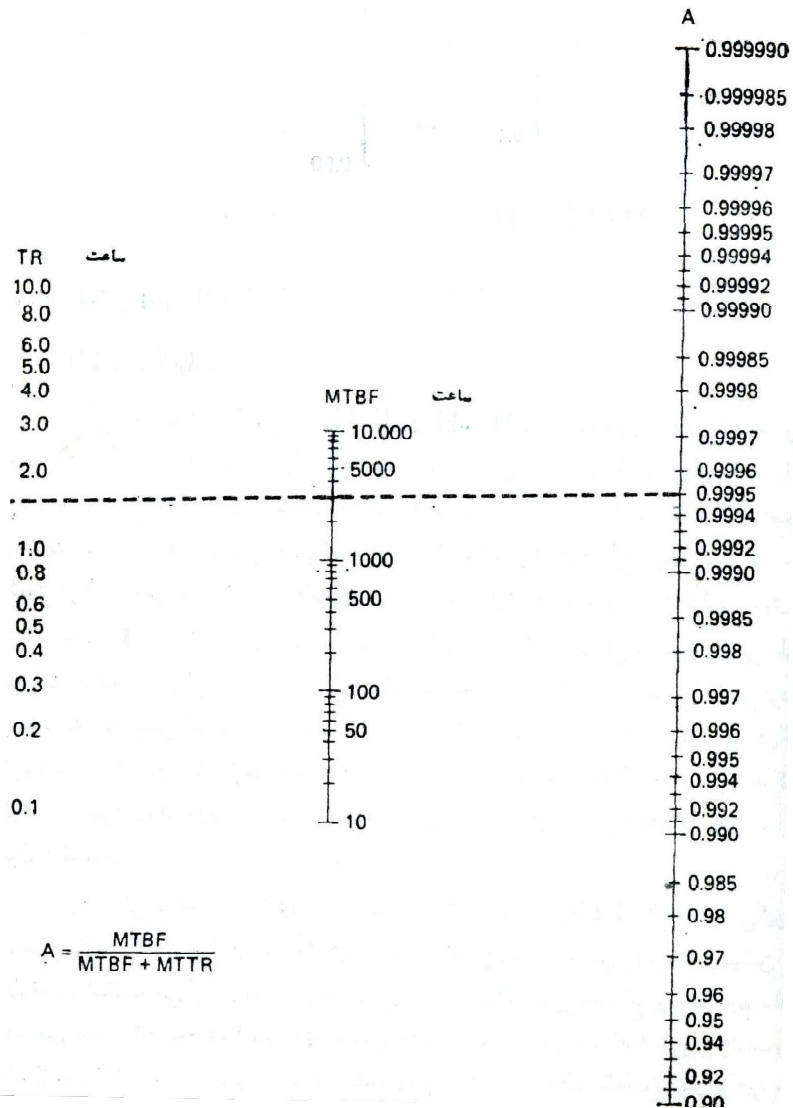

Fig. 7.6 a nomogram form of Eq. 7-59-1 (Ebrahimi,1992 p331)

### Example 7-15

It is desired that a machine which has an exponentially distributed lifetime with mean 3000 hours to possess a steady-

state availability of 99.95%. What should be the mean time to repair(MTTR)?

### Solution

Using Eq. 7-59-1:

$$A = \frac{MTBF}{MTBF + MTTR} \Rightarrow 0.9995 = \frac{3000}{3000 + MTTR} \Rightarrow MTTR = 1.6 \text{ hr}$$

Using the nomograph of Fig 7-6

The line connecting 3000 on the MTBF scale to 0.995 on Scale A, gives MTTR=.6 on MTTR scale.

### 7-3-5 Intrinsic availability in long range

The intrinsic availability in steady state can be calculated from (K&L page 228,Stapl, 2009 p 344):

$$A_{I(steady)} = \frac{MTBF}{MTBF + m.a.r.t.} \quad (7-59-2)$$

Where m.a.r.t is the mean of actual repair time.

Notice that

-Actual repair time does not include logistic and administrative times as has been shown in Fig 7.5 for a deterministic case.

-The nomogram of Fig. 7-6 could be used for this relationship.

**Example 7-16**

A series system has 2 subsystems. One the is a compressor with 80.37 failures per  $10^6$  working hours. The average of its actual repair time is 89.3 hr. The other subsystem failure rate is 4.78 failures per  $10^6$  working hours and the actual repair time on the average is 890.3. Calculate 26280-hr reliability of the each subsystem , their steady state intrinsic availability

**Solution**

Constant failure rate  $\lambda$  implies that the life time distribution is exponential with mean  $\theta = \frac{1}{\lambda}$  and reliability function  $e^{-\frac{t}{\theta}}$ . therefore

For compressor:

$$\lambda_1 = 80.37 \times 10^{-6} \Rightarrow$$

$$\theta_1 \text{ or } MTBF_1 = 1/80.37 * 10^6 = 12442.4$$

$$R_1(t) = \exp(-t/\theta_1)$$

$$R_1(26280) = \exp(-26280 * 80.37 * (10^{-6})) = 0.1210$$

$$A_1 = \frac{MTBF_1}{MTBF_1 + m.a.r.t_1} = \frac{12442.4}{12442.4 + 89.3} = 0.9929$$

For other subsystem

$$\lambda_2 = 4.78 \times 10^{-6}$$

$$\theta_2 \text{ or } MTBF_2 = 1/4.78 * 10^6 = 209205 \text{ hr}$$

$$R_2(26280) = \exp(-26280 * 4.78 * (10^{-6})) = 0.8819$$

$$A_2 = \frac{MTBF_2}{MTBF_2 + m.a.r.t_2} = \frac{209205}{209205 + 890.3} = 0.9958 \blacktriangle$$

### 7-3-6 Mission Availability

The average of reliability function,  $A(t)$ , over time period  $T$  in some references is denoted by  $A^*(T)$  and named mission availability or interval availability. Given the availability function over a period  $(0, T)$ ,  $A^*(T)$  is calculated as follows:

$$A^*(T) = \frac{1}{T} \int_0^T A(t) dt \quad (7-60)$$

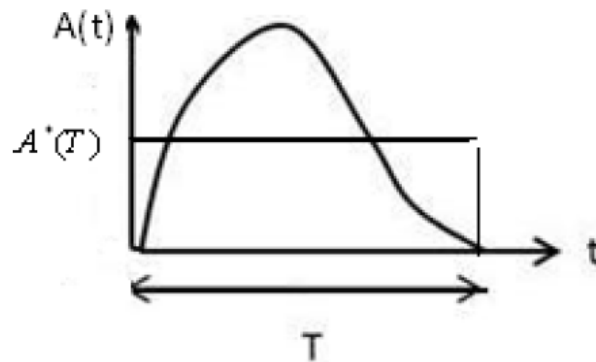

Fig 7.7 The average of a typical availability function

Figure 7-7 shows this integration graphically.

Since for a non-repairable system its availability equals its reliability at time  $t$ :  $A(t) = R(t)$  therefore (Lewis, 1994 p301):

$$A^*(T) = \frac{1}{T} \int_0^T R(t) dt \quad (7-61)$$

That is the mission availability and the average of the reliability function related to the same time period are equal.

**Example 7-17**

The lifetime of a non-repairable switch with known MTTF is exponentially distributed with parameter  $\lambda_s$ .

a) Calculate the parametric average of the reliability function of the switch.

b) (Lewis, 1994 p301)

The system mission availability must be 0.95. Find the maximum design life that can be tolerated in terms of the MTTF.

**Solution**

a) For this switch which is non-repairable,  $A^*$  i.e. the mission availability equals the average of the reliability function ( $P_s$ ).

$$P_s = A^*(T) = \frac{1}{T} \int_0^T R(t) dt \quad TTF \sim \exp(\lambda) \Rightarrow R(t) = e^{-\lambda_s t}$$

$$P_s = \frac{1}{T} \int_0^T e^{-\lambda_s t} dt = \frac{1 - e^{-\lambda_s T}}{\lambda_s T}$$

Since the Taylor expansion of  $f(x)$  about  $a$  is;

$$f(x) = f(a) + \frac{1}{1!}(x-a)f'(a) + \frac{1}{2!}(x-a)^2 f''(a) + \dots$$

Then the expansion of  $e^{-\lambda T}$  about  $a=0$  :

$$e^{-\lambda_s T} = e^{-\lambda_s(0)} + \frac{T-0}{1!}(-\lambda_s)e^{-\lambda_s T}|_{T=0} + \frac{(T-0)^2}{2!}[-\lambda_s(-\lambda_s)e^{-\lambda_s T}]|_{T=0} + \dots \Rightarrow$$

$$e^{-\lambda_s T} = 1 - \lambda_s T + \frac{1}{2}(\lambda_s T)^2 + \frac{1}{6}(\lambda_s T)^3 + \dots$$

Then for  $\lambda_s T \ll 1$ , approximately  $e^{-\lambda_s T} \cong 1 - \lambda_s T + \frac{1}{2}(\lambda_s T)^2$  and:



$$P_s = \frac{1 - e^{-\lambda_s T}}{\lambda_s T} \cong \frac{1 - 1 + \lambda_s T - \frac{1}{2}(\lambda_s T)^2}{\lambda_s T} = 1 - \frac{1}{2}\lambda_s T = A^*(T)$$

b)  $A^*(T) = 0.95$  then

$$0.95 \cong 1 - \frac{1}{2}\lambda_s T \Rightarrow T \cong \frac{1}{10\lambda_s} \Rightarrow T \cong 0.1 \times MTTF$$

End of Example ▲

### 7-3-7 System Availability in terms of components'

#### Availability

As stated earlier according to Ross(985) page 402 :

"If the on & off distributions for component  $i$  are arbitrary continuous distributions with respective mean  $\frac{1}{\lambda_i}$  &  $\frac{1}{\mu_i}$   $i = 1, 2, \dots, n$  then it follows from the theory of alternating renewal process (see page 287 of Ross,1985) that  $A_i(t)$  in the long range approaches to

$$A_i(t) \rightarrow A_i = \frac{\frac{1}{\lambda_i}}{\frac{1}{\lambda_i} + \frac{1}{\mu_i}} \quad (7-62)$$

Where  $\frac{1}{\lambda_i}$  is the mean lifetime of component  $I$  and  $\frac{1}{\mu_i}$  is the mean of its downtime.

Consider a system composes of  $n$  independent components with reliabilities  $R_1, \dots, R_n$  . Let  $f(R_1, \dots, R_n)$  denoted the system reliability function. The steady state availability of the system ,A, is calculated from( according to examples on page 402 Ross1985)::

$$A = f(A_1, \dots, A_n) \quad (7-63)$$

where

$f$	The reliability function of n-component system such as Eq. 2-1 or Eq.2-3.
$A_i = \frac{\frac{1}{\lambda_i}}{\frac{1}{\lambda_i} + \frac{1}{\mu_i}}$	The steady-state availability of component $i$ which replaces $R_i$ in $f(R_1, \dots, R_n)$
$\frac{1}{\lambda_i}$	The average lifetime of component $i$
$\frac{1}{\mu_i}$	The average downtime of component $i$

### Example 7-18

The lifetime and downtimes of  $n$  independent components, on the average, are  $\frac{1}{\lambda_i}$  and  $\frac{1}{\mu_i}$ ,  $i=1, \dots, n$  and their reliability are  $R_1, \dots, R_n$ . Calculate the parametric expression for the steady state availability of the system in both series and parallel configuration.

#### Solution

For series configuration:  $R_{sys} = f_1(R_1, \dots, R_n) = R_1 \times \dots \times R_n$

Therefore according to Eq. 7-63 the steady-state availability of the series configuration of the  $n$  components is:

$$A_{series} = f_1(A_1, \dots, A_n) = \frac{\frac{1}{\lambda_1}}{\frac{1}{\lambda_1} + \frac{1}{\mu_1}} \times \dots \times \frac{\frac{1}{\lambda_n}}{\frac{1}{\lambda_n} + \frac{1}{\mu_n}}$$

For parallel configuration:

$$R_{sys} = f_2(R_1, \dots, R_n) = 1 - (1 - R_1) \times \dots \times (1 - R_n)$$

$$A = f(A_1, \dots, A_n) = 1 - \left(1 - \frac{\frac{1}{\lambda_1}}{\frac{1}{\lambda_1} + \frac{1}{\mu_1}}\right) \dots \left(1 - \frac{\frac{1}{\lambda_n}}{\frac{1}{\lambda_n} + \frac{1}{\mu_n}}\right) \blacktriangle$$

### Example 7-19

A 2-unit system fails when either of its units fail. The units have the steady state availability of 0.9958 and 0.9929. Calculate the steady state availability of the system.

### Solution

The configuration is series.

$$R_{sys} = f(R_1, R_2) = R_1 \times R_2$$

$$A = f(A_1, A_2) = A_1 \times A_2 \quad A = 0.9929 * 0.9958 = 0.9887 \blacktriangle$$

### 7-3-8 The steady-state availability in Preventive Maintenance

From O'connor (2003 )page 402:

"Maintainability affects availability directly. The time taken to repair failures and to carry out routine preventive maintenance removes the system from the available state. There is thus a close relationship between reliability and maintainability, one affecting the other and both affecting

availability and costs. In the steady state, i.e. after any transient behavior has settled down and assuming that maintenance actions occur at a constant rate" (O'connor,2003 page 402):

$$A = \frac{MTBF}{MTBF + MTTR} \times \frac{C}{C + T} \quad (7-64)$$

where

C= Preventive maintenance cycle [ e.g. every 1000 hr]

T=Total time required to perform preventive maintenance tasks

### 7-3-9 Definition of Unavailability Function

The unavailability is the event that at a point of time a system or a device does not perform its duty under specific conditions. If the value of steady state availability is A the unavailability in steady state would be 1-A.

### Unavailability Function: Lifetime Exponential

In a special case where the lifetime and downtime are exponentially distributed, the Instantaneous unavailability function would be (O'Connor, 2003 page168):

$$U(t) = 1 - \frac{\mu}{\mu + \lambda} - \frac{\lambda}{\lambda + \mu} e^{-(\lambda + \mu)t} = \frac{\lambda}{\lambda + \mu} (1 - e^{-(\lambda + \mu)t}) \quad (7-65)$$

## 7-4 Application of Markov Chains to System Reliability Analysis

In this section we would like to have a glance at the application of Markov chains to the reliability analysis of repairable or nonrepairable systems whose lifetime follow exponential distribution. For other distributions Monte Carlo simulation is applicable. See references such as Chap. 8 of Smith(1993).

If each component has approximately an exponential failure law, the complete system can be described approximately by a Markov process and to predict the future state of the system, knowledge of the history of such systems contains no predictive value( extracted from Barlow & Proschan,1996 page119).

Figure 7-8 shows the state space of a 2-unit critical system. In this system two identical computers A & B are connected in parallel in such a way that both are operating although only one is in actual service. At a time of a computer failure, repair is done readily. Preventive maintenance for a specified computer is scheduled after  $t_0$  hours if one computer is active and the other is on an operating standby basis. If the first computer fails and the second fails during the downtime the first one the consequences could be catastrophic(Barlow & Proschan,1996 p120).

Fig 7-8 shows a diagram of the state space of the critical system. The possible states are denoted by symbols such as  $A_a$  (Computer A is active),  $B_s$  (Computer B is in standby mode)

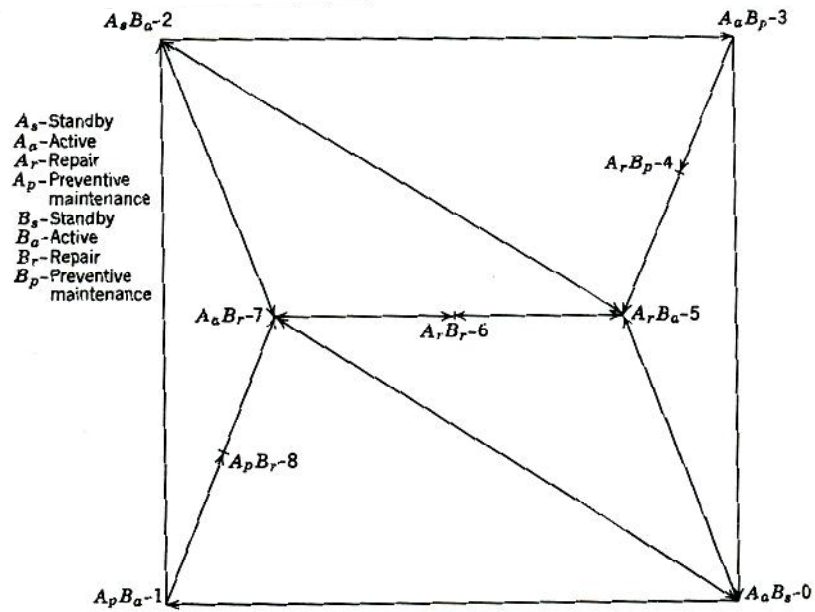

Fig. 1.1. State space for two-unit system.

Fig 7-8 The 9 possible states of a two-unit system (Barlow and Proschan, 1996p120)

The state space has 9 states labeled 0 through 8. For example state 0 indicates that computer A is used actively while computer B is operating and standby. If no failures occur in a time interval of length  $t_0$ , measured from the moment the system enter State 0, preventive maintenance is performed on computer A and State 1 begins. If no failure occurs, the state

passes around the perimeter of the square.... States 4,6 & 8 are unfavorable. (Barlow and Proschan , 1996page121).

The user of this system may be interested in such information as the mean system down time during a specified time interval, the probability that the system is down more than  $x$  minutes at any one time. Under certain reasonable assumptions on time to failure(TTF) , the time to perform repair(TTR), etc. The operation of the system can be described by a semi-Markov process to get the desired information. Chapter 5 of Barlow& Proschan(1996) deal with this system in detail.

As another example consider a system having 3 components or units a, b, c. To use a Markov chain the states of this system are defined as combinations of operating and failed components. As the following table shows the system, depending on the operation or failure of the components(o=operating X= failed), has 8 states(Lewis,1994page 326):

unit	State								
	1	2	3	4	5	6	7	8	
a	o	X	o	o	X	X	o	X	
b	o	o	X	o	X	o	X	X	
c	o	o	o	X	o	X	X	X	
o=operating				X= failed					

Chapter 11 of Lewis(1994) deals with Markov analysts of 3 configurations related to this case and it is worth mentioning that many references deal with the application of Markov

process to reliability theory; e.g. Dhillon(2006) pages 49-54.  
Barlow & Proschan(1996) page 120 and pages 192-197.

## Exercises

1. A system composing 20 independent components, each having failure rate  $0.0001 + 0.0005t$ , fails when one its components fail. Calculate the system failure rate and its reliability for  $t=10$ .

Hint: Use Eq. 7-2 for calculating the failure rate.

2. A standby parallel system has identical active unit and redundant standby unit with constant failure rate  $\lambda$ . Show that the instantaneous failure rate function for the system

$$\text{is: } h_{\text{standby}}(t) = \frac{\lambda^2 t}{1 + \lambda t},$$

3. Derive Eq. 7-51 by the help of 7-50 i.e. prove that in a two-component load sharing parallel system with pdf  $g(t) = \lambda_g e^{-\lambda_g t}$  under shared load and pdf  $f(t) = \lambda_f e^{-\lambda_f t}$  under full

load,  $R_{\text{sys}}(t) = e^{-\lambda_g t} + \frac{\lambda_g}{\lambda_g - \lambda_f} (e^{-\lambda_f t} - e^{-\lambda_g t})$  would be the system reliability.

Helping one person might not change  
the whole world, but it could change  
the world for one person



# Chapter 8

## Enhancement, Optimization & Allocation of Reliability

# 8

## Enhancement, Optimization & Allocation of Reliability

### Aims of the chapter

Due to the importance of the design phase in setting the reliability of products, this chapter deals with how to enhance, optimize reliability and to allocate reliability to each component in the system to have a more reliable design.

### 8-1 Enhancement(Improvement) of system reliability

There are two conventional approaches to improve the reliability of a system(based on Shooman,2002 page 335):

- 1)Enhancing the reliability of the system components
- 2)Active(or hot) redundancy and standby redundancy

These two approaches are described below.

#### 8-1-1 Improving Component reliability

An approach for enhancing the reliability of a system is improving the reliability of the basic elements,  $R_i$ , by allocating some or all of the cost budget to fund redesign for higher

reliability.( Shooman,2002 page 335) Figure 3-3 and 305 could help to clarify this approach.

### Example 8.1

The series system shown in Fig. 8.1 is composed of  $k=3$  identical components with a reliability of 0.80 each.

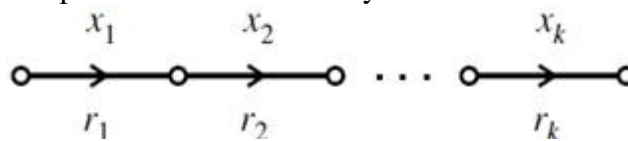

Fig. 8-1 A k-component series system.

- a) Calculate the current reliability of the system.
- b) What do you suggest for the reliability of each component in order to enhance the system reliability to 0.95?

### Solution

- a)  $R=0.8^3=0.512$ .
- b) The enhancement requires that each component has the reliability of  $\sqrt[3]{0.95}$ . End of Example ▲

### 8-1-2 Active(Hot) and standby redundancy

Another approach to enhance systems reliability is to place redundant components in parallel with the operating components either in active(hot) or standby status.

**8-1-2 Active redundancy**

In this way of enhancement components are placed in parallel with the subsystems that operate continuously (see Fig. 8.2) This is ordinary parallel redundancy(hot redundancy).

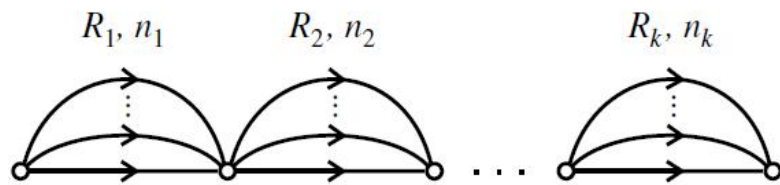

Fig. 8-2 The k-component system with active redundancy.  
(Shoorman,2002 p336)

**8-1-2 Standby redundancy**

This form of redundancy places components in standby parallel with k subsystems and switch them in when an on-line failure is detected(Shoorman,2002 page336). Figure 8.3 shows this case. The redundant components of the system shown in the figure are cold. On the figure  $\lambda$  denotes the failure rate of the operating unit and  $\lambda_{off}$  denotes the failure rate of the redundant unit in the standby mode.

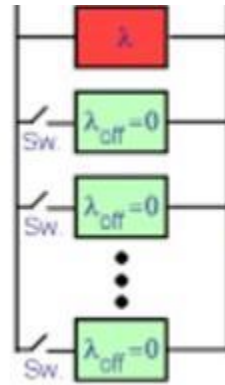

Fig. 8.3 A standby redundant parallel system

A combination of active and standby redundancy is shown in Fig. 8-4

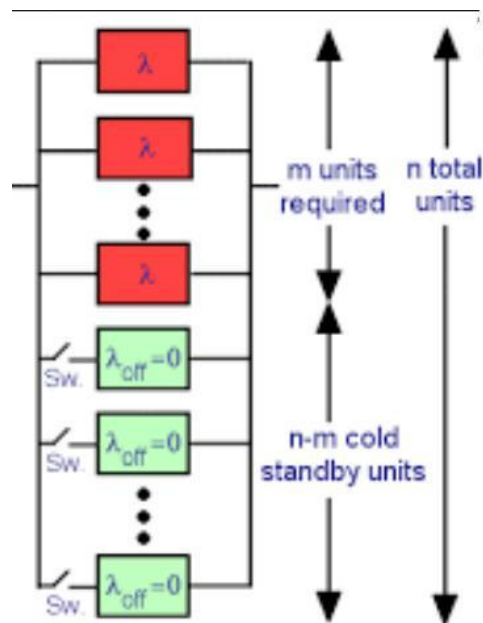

Fig 8-4 Combination of active and standby redundancy<sup>1</sup>.

<sup>1</sup> [https://reliabilityanalyticstoolkit.appspot.com/standby\\_redundancy\\_integrate](https://reliabilityanalyticstoolkit.appspot.com/standby_redundancy_integrate)

## 8-2 Reliability Optimization

Optimization play a distinguished role in system design, Its objective in reliability subject is to help developing a more effective and safe design that works within existing constraints.

Two conventional reliability optimization problems are: maximizing system reliability with cost constraints or minimizing system cost subject to the constraint that the reliability be greater than a given minimum. As an application you know that adding redundant components in parallel to a system improves the system reliability. However this approach enhances the cost, weight and volume of the system. Therefore an optimization problem has to be presented and solved in such a way that the optimum design considers the constraints as well as maximizing the reliability.

To write a general model, let  $\mathbf{x} = (x_1, \dots, x_k)$  be the decision variables; the model could be written as follows:

$$\text{Min / Max } f(\mathbf{x})$$

$$\text{s. t. } g_i(\mathbf{x}) \leq 0 \quad i = 1, 2, \dots, m$$

$$h_j(\mathbf{x}) = 0 \quad j = 1, 2, \dots, p$$

$$\mathbf{x} \geq 0$$

$f$  could be a cost function, the reliability function in the system (series, parallel, structural load-strength systems...) or the average lifetime.

As an illustration consider the following series-parallel system shown in Fig 8-5.

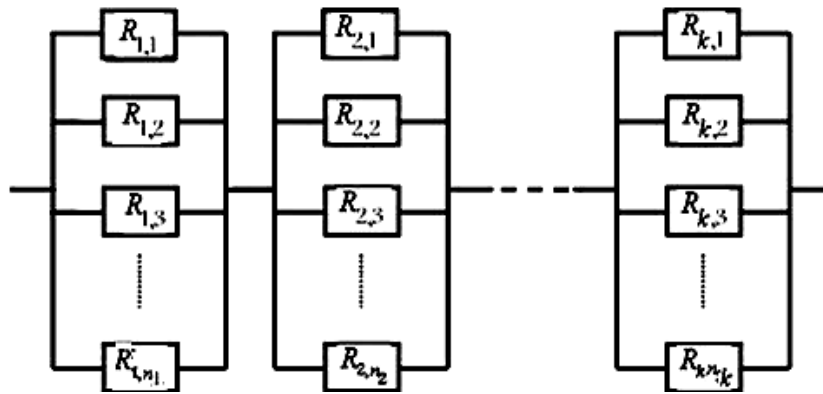

Fig.8-5 A series-parallel system(Faghii,1996 p102)

Total number of components in the system is  $\sum_{i=1}^k n_i$ . If we suppose the components in Subsystem  $i$  are identical, each having reliability  $R_i$ , then

The reliability of 1<sup>st</sup> subsystem =  $1 - (1 - R_1)^{n_1}$ ,

The reliability of 1<sup>st</sup> Subsystem  $i$  =  $1 - (1 - R_i)^{n_i}$ .

The reliability of the entire system is:

$$R_{sys} = \prod_{i=1}^k [1 - (1 - R_i)^{n_i}] \quad (8-1)$$

where

$k$  = number of subsystems

$R_i$  = The reliability of each component in Subsystem  $i$

$n_i$  = Number of components in Subsystem  $i$

Now let

$k$  = Maximum budget available

$C_i$  = The cost of each component in Subsystem  $i$

Then :

$$\sum_{i=1}^k n_i C_i \leq C ; \quad (8-2)$$

And given specified values of  $R_i, i=1,2,\dots,k$ , the problem would be determine  $n_i, i=1,2,\dots,k$  in such a way that the reliability of the system is maximized and the constraints be satisfied. The model could be written as:

$$Max R_{sys} = f(n_1, \dots, n_k) = \prod_{i=1}^k [1 - (1 - R_i)^{n_i}]$$

*s.t.*

$$\sum_{i=1}^k n_i C_i \leq C$$

$$0 < R_i < 1 \quad i = 1, \dots, k$$

$$n_i \geq 0 \quad n_i = \text{Integer}$$

Another sample model could be the following:

$$Max R = \prod_{i=1}^k [1 - (1 - R_i)^{n_i}]$$

*s.t.*

$$\sum_{i=1}^k a_{ij} n_i \leq b_j \quad i = 1, 2, \dots, k \quad j = 1, 2, \dots, m$$

$$0 < R_i < 1$$

$$n_i \geq 0 \quad n_i = \text{Integer}$$

where

$a_{ij}$  Amount of  $j$ th material used for components of  $i^{\text{th}}$  subsystem

$b_j$  Amount of  $j$ th material available

$k$  Number of subsystems



- $m$     Number of materials  
 $n_i$     Number of components in  $i^{\text{th}}$  subsystem

Cost function and MTTF or MTBF could be the objective function. The following model which determines the optimum values of  $n_i, i = 1, \dots, n$  such that the cost is minimized and ensures that the system reliability will not be less than  $R_0$  :

$$\text{Min } Z = \sum_{i=1}^k n_i C_i$$

s.t.

$$R_{\text{sys}} = \prod_{i=1}^k [1 - (1 - R_i)^{n_i}] \geq R_0$$

$$0 < R_i < 1 \quad i = 1, \dots, k$$

$$n_i \geq 0$$

$$n_i = \text{Integer}$$

To maximize the system mean lifetime of the system in Fig 8.5 and ensuring that the system reliability exceeds  $R_0$ , the following model could be used:

$$MaxZ = (MTTF)_{sys} = Min\{MTTF_i, i = 1, 2, \dots, k\}$$

*s.t.*

$$\prod_{i=1}^k [1 - (1 - R_i)^{n_i}] \geq R_0$$

$$0 < R_i < 1 \quad i=1, 2, \dots, k$$

$$n_i \geq 0$$

$$n_i = Integer$$

Remember that if an active parallel configuration has  $n_i$  exponentially-distributed-lifetime components with identical parameters  $\theta_1 = \dots = \theta_{n_i} = \theta$ , then according to Eq. 7-15

$$MTTF_i = \theta \sum_{h=1}^{n_i} \frac{1}{h}$$

To know more about reliability optimization, the reader could read references such as Chap 6 of Barlow&Proschan(1996).

### 8-2-1 Methods for the solution of The above problems

There are several methods and softwares for solving reliability optimization problems including(Yi-Chic,2002):

1.Exact methods (such as Brach and bound algorithm, dynamic programming, Cutting plane algorithm, Surrogate constraint method). This methods are time consuming for large-scale problems. Kuo and Prasad (2000) provides a good overview of the methods that have been developed since 1977 for solving various reliability optimization problems.

2. Heuristic methods, Artificial intelligence (Genetic algorithms, Simulated annealing, Artificial neural networks, Tabu search, ...) and other methods such as Lagrange multiplier technique, geometric programming, Random search; some of these methods give approximate solution.

**Notice that:**

-For application of optimization to structural reliability see references such as K&L page 423 and Xie, Zhai (2021)

-If we have simultaneous objective functions such as  $(f_1, \dots, f_{N-1}, f_N)$  which are to be maximized and  $(f'_1, \dots, f'_{L-1}, f'_L)$  subject which are to be minimized subject to constraints  $(g_1, \dots, g_m) \geq, \leq, = 0$ ; **multi-criteria decision making (MCDM)** techniques could be used. A mathematical model of an MCDM problem could be written as follows:

$$\begin{aligned} & \text{Max}\{f_1(\mathbf{x}), f_2(\mathbf{x}), \dots, f_N(\mathbf{x})\} \\ & \text{Min}\{f'_1(\mathbf{x}), f'_2(\mathbf{x}), \dots, f'_L(\mathbf{x})\} \\ & \text{s.t.} \\ & g_i(\mathbf{x}) \{ \leq, =, \geq \} 0 \quad i = 1, 2, \dots, m \\ & \text{where } \mathbf{x} \text{ is a vector including the decision variables} \end{aligned}$$

### 8-3 Reliability Allocation <sup>1</sup>

In the subject of reliability there is a problem called reliability allocation in which it is discussed how much the reliabilities of all or some of the components or subsystems

---

<sup>1</sup> The reference of this chapter is mainly K&L, Chap 14.

$(R_1, R_2, \dots)$  of a given system should be to achieve a specified overall system reliability ( $R_0$ ). This process requires solving the following inequality(K&L page 404):

$$f(R_1, R_2, \dots, R_n) \geq R_0 \quad (8-3)$$

Where

- $R_i$  The unknown reliability of component  $i$
- $R_0$  The required reliability for the system
- $f$  The functional relationship between the components and the system

Time and cost could be included in the problem , i.e.  $R_i$ 's be time-dependent and total cost be minimized.

The solution procedure is not difficult for series, parallel and k-out- n configuration; however the solution for complex configuration is not mathematically easy.

Most of the basic reliability allocation models are based on the assumption that component failures are independent, the failure of any component results in system failure (i.e., the system is composed of units in series), and that the failure rates of the components are constant. The independence assumption leads to the following equation

$$f(R_1, R_2, \dots, R_n) = R_1(t) \dots R_n(t) \geq R_0(t) \quad (8-3-1)$$

Let  $\lambda_i$  = constant failure rate of the  $i$ th component. The system has a series configuration. Therefore the lifetime of the system is the minimum of the component lifetimes which are of exponential form; therefore the lifetime of the system is exponentially distributed. As a special case of Eq. 8-3-1, if the goal value of the failure rate of the system is  $\lambda_0$ , then Eq. 8-3-1 becomes (K&L p 407):

$$e^{-\lambda_1 t} \dots e^{-\lambda_n t} \geq e^{-\lambda_0 t} \quad (8-4)$$

or

$$\lambda_1 + \lambda_2 + \dots + \lambda_n \leq \lambda_0 \quad (8-5)$$

Theoretically, the above equation has an infinite number of solutions, assuming no restrictions on the allocation. The problem is to establish a procedure that yields a unique or limited number of solutions by which consistent and reasonable reliabilities may be allocated<sup>1</sup>. Some of these procedures are:

1. Equal Apportionment Technique
2. ARINC Apportionment Technique
3. AGREE Apportionment Technique
4. Feasibility of Objective apportionment
5. Repairable System Apportionment
6. Minimum Effort Algorithm
7. Growth apportionment

---

<sup>1</sup> From: <http://reliabilityanalytics.com/blog/2011/10/09/reliability-allocation/>

## 8. Dynamic Programming

The first 3 methods are described below

### 8-3-1 Equal Apportionment Technique(ETA)

This technique allocates equal reliability to the  $n$  components of the system to achieve the system reliability requirement. When no information on the system is available, other than the fact that  $n$  components are to be used in series or parallel, equal apportionment( $R$ ) to each subsystem would seem reasonable. Furthermore allocation of the same reliability( $R$ ) to all components of a k-out-of-n system is usual.

For series configuration,  $n^{\text{th}}$  root of the system reliability requirement( $R_0$ ) would be apportioned to each subsystem:

$$R_0 = R_1 \times R_2 \times \dots \times R_n \Rightarrow R_0 = R^n$$

$$R_i = R = \sqrt[n]{R_0} \quad i = 1, \dots, n \quad (8-5-1)$$

For active parallel configuration, according to Eq. (2 - 3 - 1):

$$R_0 = 1 - (1 - R_1) (1 - R_2) \dots (1 - R_n)$$

$$R_i = R \quad i = 1, \dots, n \Rightarrow$$

$$R_0 = 1 - (1 - R)^n = 1 - R_0 \Rightarrow 1 - R = \sqrt[n]{1 - R_0} \Rightarrow$$

$$R = 1 - \sqrt[n]{1 - R_0} \quad (8-5-2)$$

And for k-out-of-n configuration, according to Eq. 2-5 (Chap 2):

$$R_0 = \sum_{x=0}^{n-k} \binom{n}{x} (1-R)^x (R)^{n-x}$$

Given  $R_0$ ,  $k$  and  $n$ ,  $R$  has to be determined in such a way that

$$\left( \sum_{x=0}^{n-k} \binom{n}{x} (1-R)^x (R)^{n-x} - R_0 \right) = 0.$$

This could be done using a software.

### Example 8-2

The reliability requirement for a 3-component series system is  $R_0 = 0.8573$ . Find the reliability of each component using equal apportionment technique.

### Solution

According to Eq. 8-5-1:

$$R = \sqrt[n]{R_0} \quad n = 3 \quad R_0 = 0.8573$$

The reliability of each component is;

$$R = \sqrt[3]{0.8573} = 0.95 \quad \blacktriangle$$

### Example 8-3

The reliability of a 3-component active parallel system is required to be  $R_0 = 0.8573$ . Use ETA to determine the reliability of each component.

**Solution**

According to Eq. 8-5-2:

$$R = 1 - \sqrt[n]{1 - R_0} \quad n=3 \quad R_0 = 0.8573 \Rightarrow$$

$$R = 1 - \sqrt[3]{1 - 0.8573} = 0.4774 \blacktriangle$$

**Example 8-4**

The reliability of a 3-out-of-5 configuration is required to have the reliability of  $R_0 = 0.99144$ . Calculate  $R$ , the reliability of each of the five components.

**Solution**

According to Eq.2-5 in Chap. 2,  $R$  is derived from:

$$R_0 = \sum_{x=0}^{n-k} \binom{n}{x} (1-R)^x (R)^{n-x}$$

then:

$$\sum_{x=0}^{5-3} \binom{5}{x} (1-R)^x (R)^{5-x} - 0.99144 = 0$$

The following MATLAB commands yields  $R = 0.9$ .

`f=inline('binocdf(5-3,5,1-R)-0.99144');R=fzero(f,0.5).  $\blacktriangle$`



### 8-3-2 The ARINC apportionment technique for series system with independent subsystems having exponential lifetimes

The ARINC allocation method was developed by a research center associated with Aeronautical Radio Incorporation. This method is applicable to a series system whose subsystems have constant failure rate( $\lambda_i$ ) and their mission times equal the system mission time. Let

$\lambda_i^*$  The allocated failure rate to the  $i^{th}$  subsystem

$\lambda_0$  The desired failure rate given for the entire system

The ARINC method tries to choose  $\lambda_i^*$  such that(K&L p 407):

$$\lambda_1^* + \dots + \lambda_n^* \leq \lambda_0$$

Steps of ARINC apportionment technique are(K&L page408):

I. Determine the subsystem failure rates ( $\lambda_i, i = 1, 2, \dots$ ) from the past data, observed or estimated.

II. Assign a weighting factor ( $w_i$ ) to each subsystem according to the failure rates determined in step I, where  $w_i$  is given by

$$w_i = \frac{\lambda_i}{\sum_{i=1}^n \lambda_i} \quad (8-6)$$

III. Allocate new subsystem failure rates ( $\lambda_1^*$ 's) calculated from the following relationship( assuming  $\lambda_1^* + \dots + \lambda_n^* = \lambda_0$ );

$$\lambda_i^* = w_i \lambda_0 \quad (8-7)$$

where  $\lambda_0$  is the desired failure rate for the entire system.

**Example 8-5**(based on Example 14.2 K&L page408)

Consider a series system composed of three subsystems with constant failure rates. The mean lifetimes are 200, 333, and 1000 hours respectively. The system has a mission time of  $t=20$  hours. A system reliability of 0.95 is required( $R_0 = 0.95$ ). Use ARINC method to find the reliability requirements for the subsystems.

**Solution**

Since the failure rates of the subsystems are constant, their lifetimes are exponentially distributed and the lifetime distribution of this series system is also exponential. Therefore the ARINC method could be used:

$$\lambda_1 = \frac{1}{\theta_1} = \frac{1}{200} = 0.005, \quad \lambda_2 = 0.003, \quad \lambda_3 = 0.001$$

$$\lambda_i^* = w_i \lambda_0, \quad w_i = \lambda_i / \sum_{i=1}^n \lambda_i$$

$$w_1 = \frac{0.005}{0.005 + 0.003 + 0.001} = 0.555, \quad w_2 = 0.333,$$

$$w_3 = 0.111$$

To find the required failure rate() for this exponentially-distributed-lifetime system we could write:

$$R_0(20) = e^{-20\lambda_0} \Rightarrow 0.95 = e^{-20\lambda_0} \Rightarrow \lambda_0 = 0.00256 \text{ per hour}$$

The required failure rate for each subsystem is calculated from Eq. 8-7 i.e.  $\lambda_i^* = w_i \lambda_0$  as follows:

$$\lambda_1^* = (0.555)(0.00256) = 0.00142$$

$$\lambda_2^* = (0.333)(0.00256) = 0.000582$$

$$\lambda_3^* = (0.111)(0.00256) = 0.000284$$

Since the lifetime of each subsystem is exponentially distributed, the allocated reliability for them to ensure a 20-hour operation of the system are:

$$R_1^*(20) = e^{-20\lambda_1^*} = e^{-20(0.00142)} = 0.97$$

$$R_2^*(20) = e^{-20\lambda_2^*} = 0.98, \quad R_3^*(20) = 0.99 \quad \blacktriangle$$

### 8-3-3 The AGREE allocation method for pseudo-series system with independent exponential-lifetime subsystems

A method of apportionment is outlined by the Advisory Group on the Reliability of Electronic Equipment (AGREE) takes into consideration both the complexity and importance of each subsystem. In this method for each subsystem a factor called importance index is introduced to express the degree of importance between the system failure and the subsystem. It is assumed that the subsystems have constant failure rates.

The method applies to any unit that can be decomposed into a series of independent subsystems (Grosh, 1989 p149); some of

which are taken out of the system before the end of the mission time considered for the system. Notice that the total system under consideration is not truly a series system unless all of the importance indices ( $w_i$ 's) equal unity and the mission time of all subsystems ( $t_i$ 's) are equal (Grosh, 1989 p150).

To reach a target MTBF for the system, this method uses Equation 8-8 which calculates an approximate value for the MTBF of each subsystem (Grosh, 1989 p150).

$$MTBF_i = \frac{(N)(w_i)(t_i)}{n_i[-\ln R_0(t)]} \quad i = 1, 2, \dots \quad (8-8)$$

This is equivalent to

the following failure rate for the subsystem (K&L p409):

$$\lambda_i = \frac{n_i[-\ln R^*(t)]}{N w_i t_i} \quad i = 1, 2, \dots \quad (8-9-1)$$

or

the following reliability for the subsystem

$$R_i^*(t_i) = e^{-\lambda_i t_i} \quad (8-9-2)$$

where

- $n_i$  Number of components of in the  $i^{\text{th}}$  subsystem
- $N$  Total number of components in the system:  $N = \sum n_i$
- $\lambda_i$  failure rate of  $i^{\text{th}}$  subsystem
- $R_0(t)$  The required system reliability for a mission time  $t$
- $R_i^*$  The reliability allocated to  $i^{\text{th}}$  subsystem
- $t$  System mission time
- $t_i$  The mission time for  $i^{\text{th}}$  subsystem; the time period required for the  $i^{\text{th}}$  subsystem to operate from the

beginning of the operation of the system and the subsystem is not needed any more ( $0 < t_i \leq t$ )

$w_i$  Importance index for the  $i^{\text{th}}$  subsystem; probability that the system mission fails if  $i^{\text{th}}$  subsystem fails.

$w_i$  is the following quotient (Grosh, 1989 p149)

$$w_i = \frac{\text{number of mission failures owing to } i^{\text{th}} \text{ subsystem fails}}{\text{number of } i^{\text{th}} \text{ subsystem failure}}$$

$w_i = 1$  states that for the successful operation of the system, the  $i^{\text{th}}$  subsystem must work successfully.

The more  $w_i$ 's closer to 1 the better the results. Small  $w_i$ 's causes poor results by the AGREE formula .

The reliability allocated to the  $i^{\text{th}}$  subsystem is calculated from:

$$R_i^* = e^{-\lambda_i t_i} \quad (8-10-1)$$

OR

$$R_i^* = 1 - \frac{1 - [R_0(t)]^N}{w_i} \quad (8-10-2)$$

### Example 8-6 (K&L page 410)

A system consisting of four subsystems is required to demonstrate a reliability level of 0.95 for 10 hours of continuous operation. Subsystems 1 and 3 are essential for the successful operation of the system. Subsystem 2 has to function for only 9 hours for the operation of the system, and its importance factor is 0.95. Subsystem 4 has an importance factor of 0.90 and must function for 8 hours for the system to function. Solve the

reliability allocation problem by AGREE method using the data Given below:

$i$	$t_i$	$w_i$	$n_i$
1	10	1	15
2	9	0.95	25
3	10	1	100
4	8	0.9	70
sum			N=210

**Solution**

Data:  $t=10$   $N = \sum n_i = 210$  ,  $R_0(10) = 0.95$

According to Eq. 8.8 the required mean lifetime for each subsystem is:

$$MTBF_i = \frac{Nw_it_i}{n_i[-\ln R_0(t)]}$$

The equivalent failure rate is  $\lambda_i = \frac{1}{MTBF_i}$ .

$$MTBF_1 = \frac{210 * 1 * 10}{(15)(-\ln 0.95)} = 2729.4$$

$$\lambda_1 = \frac{1}{MTBF_1} = \frac{1}{2729.4} = 0.00036638 = 36638 \times 10^{-8}$$

$$MTBF_2 = \frac{210 * 0.95 * 9}{(25)(-\ln 0.95)} = 1400.2 \quad \lambda_2 = 0.0007142$$

$$MTBF_3 = \frac{210 * 1 * 10}{100(-\ln 0.95)} = 409.41 \quad \lambda_3 = 0.002442$$

$$MTBF_4 = \frac{210 * 0.9 * 8}{(70)(-\ln 0.95)} = 421.1 \quad \lambda_4 = 0.002374$$

Eq. 8-10-1&2 allocates the required reliability to each subsystem:

$$R_i^* = 1 - \frac{1 - [R_0(t)]^{\frac{n_i}{N}}}{w_i}$$

$$R_1^* = 1 - \frac{1 - (0.95)^{\frac{15}{210}}}{1} = 0.99634$$

$$\text{or } R_1^* = e^{-\lambda_1^* t_1} = e^{-(0.0007142)(9)} = 0.99634$$

similarly

$$R_2^* = 1 - \frac{1 - (0.95)^{\frac{25}{210}}}{0.95} = 0.99359$$

$$\text{or } R_2^* = e^{-\lambda_2^* t_2} = e^{-(0.00036638)(10)} = 0.99359$$

$$R_3^*(t) = 0.975870,$$

$$R_4^*(t) = 0.98116$$

These four reliabilities result in a reliability of

$R_1^* \times R_2^* \times R_3^* \times R_4^* = 0.94788 = 94.79\%$  for the system which is slightly less than the system reliability requirement 0.95. This is a result of the approximate nature of the AGREE formula and that  $w_2$  and  $w_4$  are less than unity. End of Example ▲

The readers interested in AGREE method for parallel configurations could refer to references such as Grosh (1989).

### Exercises

1. We would like to design an active parallel system of  $n$  identical subsystems. The lifetime of each subsystem is exponentially distributed with average lifetime of 100 hours. Prepare a mathematical model to determine  $n$  in such a way that the system reliability is greater than 0.95 and the average system life time is maximized. For calculating the reliabilities of subsystems use mission time of 100 hours.

2. The monthly failure rates of the subsystems of a series system are constant and their estimates are  $150 \times 10^{-5}$ ,  $18 \times 10^{-5}$ ,  $2.3 \times 10^{-5}$ ,  $5.6 \times 10^{-5}$  failure per month. Use ARINC technique to assign reliabilities to the subsystems such that the system reliability would be 0.98 for 36- month mission time.

3. (From K&L page433) A system consists of five subsystems in series. The system reliability goal is 0.990 for 10 hours of operation. The necessary information for the subsystem is given below

Subsystem No.( $i$ )	Number of subsystems		Operating time
	$n_i$	$w_i$	$t_i$
1	25	1.00	10
2	80	0.97	9
3	45	1.00	10
4	60	0.93	7
5	70	1.00	10



4. (K&L page 436) Consider the design reliability problem when both the stress(s) and the strength ( $\delta$ ) are normally distributed. The reliability goal for the component is 0.99. The cost functions and the constraints for the 4 parameters are:

parameter	The terms of the cost function	Constraints(units in MPa)
$\mu_\delta$	$0.0002 \times (\mu_\delta)^{1.135}$	$30000 \leq \mu_\delta \leq 75000$
$\sigma_\delta$	$800 \times (\sigma_\delta)^{-0.475}$	$1000 \leq \sigma_\delta \leq 10000$
$\mu_s$	$8997 \times (\mu_s)^{-0.513}$	$10000 \leq \mu_s \leq 68000$
$\sigma_s$	$366 \times (\sigma_s)^{-0.358}$	$500 \leq \sigma_s \leq 7500$

Formulate the model of this problem to determine the values of  $\mu_\delta, \mu_s, \sigma_\delta, \sigma_s$  in such a way that the sum of the terms in second column is minimized and the constraints given in the table are satisfied.

5. Solve Example 8-1 of this chapter assuming  $k=3$  active parallel components.

6. A system consists of four subsystems having constant failure rates. The system will fail if a subsystem fails. The current lifetimes of the subsystems are estimated to be 250, 142.75, 12 and 20 hours. Assign required reliability to ensure the system will have a reliability of 0.99 for a mission time of 50 hours.

**You can never satisfy people by your  
property. So, you can attract  
their satisfaction by your behaviour**

## References

- American National Standard ,1989
- Bazargan, Hamid,  
 Statistical methods in Quality control  
 Downloadable from:  
<https://opentextbc.ca/oerdiscipline/chapter/industrial-engineering> or  
<https://archive.org/details/statistical-methods-august-2020-bazargan> or  
<https://opentextbc.ca/oerdiscipline/chapter/statistics/>
- Bazovsky, Igor, 2004  
 Reliability Theory and Practice  
 Dover Publication Inc
- Barlow,E.B.& Proschan F,L1996  
 Math. Theory of Reliability,  
 S.I.A.M
- Billinton, R, Allan, R.,1992  
 Reliability Evaluation of Engineering Systems: Concepts and Techniques  
 Plenum Publishers
- Bowker, A., H. and. Leiberman, G. J., 1972  
 Engineering Statistics  
 Prentice Hall, Inc., Englewood Cliffs, N.J
- Cabarbaye,A.2019  
 Implementation of accelerated life testing  
 Cab Innovation, France([www.cabinovation.com](http://www.cabinovation.com))
- Carter,A.D.S., 1986  
 Mechanical Reliability  
 Macmillan
- Chen, Qiming, 2004  
 "The probability, identification, and prevention of rare events in  
 power systems "  
 Iowa State univ. Retrospective Theses and Dissertations.Paper 1149.
- Coles , Stuart, 2001  
 An Introduction to Statistical Modeling of Extreme Values  
 Springer Verlag, London.
- Dhillon, B.S.2006  
 Maintainability, Maintenance, and Reliability for Engineers  
 CRC Press  
 Taylor & Francis Group
- Dao-Thein, M.&Massoud,M.1974  
 On the Relation Between the Factor of Safety and Reliability  
 Jr of Engineering for Industry , 96(3): 853–857.  
 doi: <https://doi.org/10.1115/1.3438452>  
<https://citeseerx.ist.psu.edu/viewdoc/download?doi=10.1.1.1058.9057&rep=rep1&type=pdf>
- Ebeling, Charles E.1997  
 Introduction to Reliability and Maintainability Engineering  
 McGraw-Hill

- Ebrahimi, Ghanbar, 1992,  
Quality Control: "The assurance Sciences" (in Persian)  
Tehran University Publications No. 2137, Tehran
- Epstein, B., 1960  
Elements of the Theory of Extreme values  
Technometrics vol2 #1 pp27-41
- Faghih, N. 1996  
Maintenave Engineering (Persian)  
Navid Publicationm Shiraz, Iran
- Eusgeld, F.C. Freiling, and R. Reussner (Eds.): 2008  
Dependability Metrics,  
LNCS 4909, pp. 59–103, 2008. c Springer-Verlag Berlin Heidelberg
- Fegenbaum, A. V., 1991  
Total Quality Control; McGraw-Hill
- Goda, Y., 2000  
Random Seas and Design of Maritime Structures.  
2nd edition, World Scientific, Singapore.
- Gordon, E. C., 1993  
Signal and linear system analysis  
Allied publishers
- Grant, E.G. , Leavenworth, E., S., 1988  
Statistical quality control  
McGraw Hill, New York
- Grosh, D.L , 1989  
A Primer of Reliability Theory  
Wiley
- Guiqin Chen , a, Xiuling Wei, b, Gang Cui, c, Xinge Wang, d Lei Li, e, 2013  
Application of MATLAB in the Analysis of Reliability Data  
Advanced Material Research vols 760-762 pp1004-1007
- Hsyland, A., Rausand, M., 2004  
System Reliability Theory: Models, Statistical Methods & Applications  
Wiley
- IEC 60050-192:2015  
International Electrotechnical Vocabulary (IEV) - Part 192:  
Dependability
- IEC 60300-1:2014  
Dendability management - Part 1: Guidance for management and application
- IIE Terminology  
Industrial Engineering Terminology  
Institute if Industrial Engineers, McGraw-Hill
- Ireson, W.G., Coombs, C.F., Moss, R.Y. 1996  
Handbook of Reliability Engineering and Management  
McGraw Hill
- Jerkinson, A. F., 1955.  
The Frequently Distribution of The Annual Maximum (or Minimum)  
Values of Meteorological Elements.  
Quarterly Jr. of The Royal Met. Soc. Vol. 81.

- Kapur, K.C. & Lamberson, L.R.  
Reliability in Engineering Design,  
John Wiley
- Kalaiselvan, C., L. Bhaskara Rao 2016  
Comparison of reliability techniques of parametric and non-parametric method  
Engineering Science and Technology, Vol 19, Issue 2, pp 691-699
- Kaushik, A., Singh, R., 2021  
An Introduction to Probability and Statistics  
K.K publication
- King, R., 1990  
Safety in Process Industries  
Butterworth-Heinemann,
- Kuo, W. and Prasad, V, R. 2000  
An annotated overview of system-reliability optimization,  
IEEE Trans on Reliability 49 176-187.
- Kuo, Way; Lin, Hsin-Hui; Xu, Zhongkai; Zhang, Weixing; 2012  
Reliability Optimization with the Lagrange- Multiplier  
and Branch- and-Bound Technique  
Reliability, IEEE Transactions , Volume: R-36 Issue: 5
- Kuo, Way; Zuo, M.J, 2003,  
Optimal Reliability Modelling – Principles and applications  
John Wiley
- Lewis, E.E., 1994  
Introduction to Reliability Eng'g,  
Wiley
- Li, James, 2016  
Reliability Comparative Evaluation of Active Redundancy vs.  
Standby Redundancy  
Int. Jr of Math., Eng'g and Manag. Sciences Vol. 1, No. 3, 122–129
- Mann, N.R., Schafer, R.E., Singpurwala. 1974  
Methods for Statistical. Analysis of Reliability & Life Data  
Wiley
- Mathworks: Using MATLAB. 2006
- Martha de Souza, G. F., Netto, A.C., Melani, R.F., Michalski, M.A. ... Renan da Silva, 2022  
Reliability Analysis and Asset Management of Engineering Systems,  
Elsevier Inc.
- Nordmann, L., Pham, H., 1999  
Weighted voting systems  
IEEE Transactions on Reliability, 1999
- Niaki S, T., Yaghoubi, A., 2020  
Exact Equations for The Reliability and Mean Time to Failure Of  
1-Out-Of-N Cold Standby System with Imperfect Switching  
Journal of Optimization in Industrial Engineering Vol.14, Issue 2
- O'Connor, P.D., T. 2003  
Practical Reliability Engineering,  
Wiley

- O'Connor, Patrick P, Kleyner, Andre 2012  
Practical Reliability Engineering,  
Wiley
- Queiroz, I. M., 2016  
Comparison between Deterministic and Probabilistic  
Stability Analysis, Featuring Consequent Risk Assessment  
International Jr of Geotechnical and Geological Eng'g Vol:10, No:6,
- Ravinran, A. Ravi,(Editor),2016  
Operations Research and Management Science Handbook  
CRC Press
- Reuben,R,1994  
Materials in Marine Technology  
Springer-Verlag
- Ross,S.M.1985  
Introduction to probability models,  
Academic Press Edition
- Salvendy, Gavriel( Editor),2001  
Handbook of Industrial Eng'g: Technology and Operations Management  
John Wiley
- Sharpe, William, 2008  
Handbook of Experimental Solid Mechanics  
Springer Science & Business Media
- Smith, D.J.1993  
Reliability. Maintainability & Risk  
Butter worth &Heinemann
- Shooman, M.L ,2002  
Reliability of Computer systems and networks  
John Wiley
- Song, J. , Kiureghian ,A.D. 2003,  
Bounds on System Reliability by Linear Programming,  
J. Eng. Mech. 129:627-636.
- Stamatis,D.H. 2010  
The OEE Primer: Understanding Overall Equipment  
Effectiveness, Reliability, and Maintainability  
CRC press
- Stapelberg, R.F.,2009  
Handbook of Reliability, Availability, Maintainability and Safety in Engineering Design  
Springer Science & Business Media
- Tersine, R., J., 1985  
Production and Operations Management  
Elsevier Science publishing Co., Amsterdam
- Thompson, W.A1988.  
Point Process Models with Applications to Safety and Reliability  
Chapman and Hall,
- Tobias, P,A, Trindade ,D,C, 2012  
Applied Reliability  
CRC Press

- Wang Wendai, Jiang, Mingxiao, 2004  
Generalized decomposition method for complex systems  
Publisher: IEEE,conference : 26-29 Jan. 2004 Los Angeles, CA, USA  
DOI: 10.1109/RAMS.2004.1285416
- Wei-Chang,Leh,2009  
A simple universal generating function method for estimating the  
reliability of general multi-state node networks  
IIE Transactions Volume 41, 2008 - Issue 1:Special Issue Honoring  
Richard Barlow
- Wenxue Qian, Xiaowei Yin, Liyang Xie, 2014  
Reliability Modeling and Assessment of Component with Multiple Weak  
Sites under Complex Loading  
Mathematical Problems in Engineering Volume 2014
- Xie, M, Gaudoin, O.,BracQuemond, C, 2002  
Redefining, failure rate function for discrete distributions  
International Journal of Reliability, Quality and Safety Engineering  
Vol. 9, No. 3 pp 275–285
- Xie, Xin, Zhai, Hao,2021  
Structural reliability optimization model with ...  
Evolutionary Intelligence , springer Published on line March 2021  
<https://doi.org/10.1007/s12065-021-00588-9>
- Yi-Chic Hsieh. 2002  
A two phase LP for redundancy allocation problem  
Yugoslav Jr of O.R.

Every thing comes to him who waits

# T A B L E S

**Table A Critical values of F distribution  $F_{m,n}$  ( Mood et al,1974 ) Example  $F_{0.1,3,1} = 53.6$**

$\alpha$	$\begin{matrix} m \rightarrow \\ n \downarrow \end{matrix}$	1	2	3	4	5	6	7	8	9	10	12	15	20	30	60	120	$\infty$
.10	1	39.9	49.5	53.6	55.8	57.2	58.2	58.9	59.4	59.9	60.2	60.7	61.2	61.7	62.3	62.8	63.1	63.3
.05		161	200	216	225	230	234	237	239	241	242	244	246	248	250	252	253	254
.025		648	800	864	900	922	937	948	957	963	969	977	985	993	1000	1010	1010	1020
.01		4050	5000	5400	5620	5760	5860	5930	5980	6020	6060	6110	6160	6210	6260	6310	6340	6370
.005		16200	20000	21600	22500	23100	23400	23700	23900	24100	24200	24400	24600	24800	25000	25200	25400	25500
.10	2	8.53	9.00	9.16	9.24	9.29	9.33	9.35	9.37	9.38	9.39	9.41	9.42	9.44	9.46	9.47	9.48	9.49
.05		18.5	19.0	19.2	19.2	19.3	19.3	19.4	19.4	19.4	19.4	19.4	19.4	19.5	19.5	19.5	19.5	19.5
.025		38.5	39.0	39.2	39.2	39.3	39.3	39.4	39.4	39.4	39.4	39.4	39.4	39.4	39.5	39.5	39.5	39.5
.01		98.5	99.0	99.2	99.2	99.3	99.3	99.4	99.4	99.4	99.4	99.4	99.4	99.4	99.5	99.5	99.5	99.5
.005		199	199	199	199	199	199	199	199	199	199	199	199	199	199	199	199	199
.10	3	5.54	5.46	5.39	5.34	5.31	5.28	5.27	5.25	5.24	5.23	5.22	5.20	5.18	5.17	5.15	5.14	5.13
.05		10.1	9.55	9.28	9.12	9.01	8.94	8.89	8.85	8.81	8.79	8.74	8.70	8.66	8.62	8.57	8.55	8.53
.025		17.4	16.0	15.4	15.1	14.9	14.7	14.6	14.5	14.5	14.4	14.3	14.3	14.2	14.1	14.0	13.9	13.9
.01		34.1	30.8	29.5	28.7	28.2	27.9	27.7	27.5	27.3	27.2	27.1	26.9	26.7	26.5	26.3	26.2	26.1
.005		55.6	49.8	47.5	46.2	45.4	44.8	44.4	44.1	43.9	43.7	43.4	43.1	42.8	42.5	42.1	42.0	41.8
.10	4	4.54	4.32	4.19	4.11	4.05	4.01	3.98	3.95	3.93	3.92	3.90	3.87	3.84	3.82	3.79	3.78	3.76
.05		7.71	6.94	6.59	6.39	6.26	6.16	6.09	6.04	6.00	5.96	5.91	5.86	5.80	5.75	5.69	5.66	5.63
.025		12.2	10.6	9.98	9.60	9.36	9.20	9.07	8.98	8.90	8.84	8.75	8.66	8.56	8.46	8.38	8.31	8.26
.01		21.2	18.0	16.7	16.0	15.5	15.2	15.0	14.8	14.7	14.5	14.4	14.2	14.0	13.8	13.7	13.6	13.5
.005		31.3	26.3	24.3	23.2	22.5	22.0	21.6	21.4	21.1	21.0	20.7	20.4	20.2	19.9	19.6	19.5	19.3



Table A -continued

.10	5	4.06	3.78	3.62	3.52	3.45	3.40	3.37	3.34	3.32	3.30	3.27	3.24	3.21	3.17	3.14	3.12	3.11
.05		6.61	5.79	5.41	5.19	5.05	4.95	4.88	4.82	4.77	4.74	4.68	4.62	4.56	4.50	4.43	4.40	4.37
.02 5		10.0	8.43	7.76	7.39	7.15	6.98	6.85	6.76	6.68	6.62	6.52	6.43	6.33	6.23	6.12	6.07	6.02
.01		16.3	13.3	12.1	11.4	11.0	10.7	10.5	10.3	10.2	10.1	9.89	9.72	9.55	9.38	9.20	9.11	9.02
.00 5		22.8	18.3	16.5	15.6	14.9	14.5	14.2	14.0	13.8	13.6	13.4	13.1	12.9	12.7	12.4	12.3	12.1
.10	6	3.78	3.46	3.29	3.18	3.11	3.05	3.01	2.98	2.96	2.94	2.90	2.87	2.84	2.80	2.76	2.74	2.72
.05		5.99	5.14	4.76	4.53	4.39	4.28	4.21	4.15	4.10	4.06	4.00	3.94	3.87	3.81	3.74	3.70	3.67
.02 5		8.81	7.26	6.60	6.23	5.99	5.82	5.70	5.60	5.52	5.46	5.37	5.27	5.17	5.07	4.96	4.90	4.85
.01		13.7	10.9	9.78	9.15	8.75	8.47	8.26	8.10	7.98	7.87	7.72	7.56	7.40	7.23	7.06	6.97	6.88
.00 5		18.6	14.5	12.9	12.0	11.5	11.1	10.8	10.6	10.4	10.2	10.0	9.81	9.59	9.36	9.12	9.00	8.88
.10	7	3.59	3.26	3.07	2.96	2.88	2.83	2.78	2.75	2.72	2.70	2.67	2.63	2.59	2.56	2.51	2.49	2.47
.05		5.59	4.74	4.35	4.12	3.97	3.87	3.79	3.73	3.68	3.64	3.57	3.51	3.44	3.38	3.30	3.27	3.23
.02 5		8.07	6.54	5.89	5.52	5.29	5.12	4.99	4.90	4.82	4.76	4.67	4.57	4.47	4.36	4.25	4.20	4.14
.01		12.2	9.55	8.45	7.85	7.46	7.19	6.99	6.84	6.72	6.62	6.47	6.31	6.16	5.99	5.82	5.74	5.65
.00 5		16.2	12.4	10.9	10.1	9.52	9.16	8.89	8.68	8.51	8.38	8.18	7.97	7.75	7.53	7.31	7.19	7.08
.10	8	3.46	3.11	2.92	2.81	2.73	2.67	2.62	2.59	2.56	2.54	2.50	2.46	2.42	2.38	2.34	2.31	2.29
.05		5.32	4.46	4.07	3.84	3.69	3.58	3.50	3.44	3.39	3.35	3.28	3.22	3.15	3.08	3.01	2.97	2.93
.02 5		7.57	6.06	5.42	5.05	4.82	4.65	4.53	4.43	4.36	4.30	4.20	4.10	4.00	3.89	3.78	3.73	3.67
.01		11.3	8.65	7.59	7.01	6.63	6.37	6.18	6.03	5.91	5.81	5.67	5.52	5.36	5.20	5.03	4.95	4.86
.00 5		14.7	11.0	9.60	8.81	8.30	7.95	7.69	7.50	7.34	7.21	7.01	6.81	6.61	6.40	6.18	6.06	5.95

Table A -continued		F <sub>m,n</sub> e.g. $F_{0.005,3,12} = 7.13$																
$\alpha$	$\begin{matrix} m \rightarrow \\ n \downarrow \end{matrix}$	1	2	3	4	5	6	7	8	9	10	12	15	20	30	60	120	$\infty$
.10	9	3.36	3.01	2.81	2.69	2.61	2.55	2.51	2.47	2.44	2.42	2.38	2.34	2.30	2.25	2.21	2.18	2.16
.05		5.12	4.26	3.86	3.63	3.48	3.37	3.29	3.23	3.18	3.14	3.07	3.01	2.94	2.86	2.79	2.75	2.71
.025		7.21	5.71	5.08	4.72	4.48	4.32	4.20	4.10	4.03	3.96	3.87	3.77	3.67	3.56	3.45	3.39	3.33
.01		10.6	8.02	6.99	6.42	6.06	5.80	5.61	5.47	5.35	5.26	5.11	4.96	4.81	4.65	4.48	4.40	4.31
.005		13.6	10.1	8.72	7.96	7.47	7.13	6.88	6.69	6.54	6.42	6.23	6.03	5.83	5.62	5.41	5.30	5.19
.10	10	3.29	2.92	2.73	2.61	2.52	2.46	2.41	2.38	2.35	2.32	2.28	2.24	2.20	2.15	2.11	2.08	2.06
.05		4.96	4.10	3.71	3.48	3.33	3.22	3.14	3.07	3.02	2.98	2.91	2.84	2.77	2.70	2.62	2.58	2.54
.025		6.94	5.46	4.83	4.47	4.24	4.07	3.95	3.85	3.78	3.72	3.62	3.52	3.42	3.31	3.20	3.14	3.08
.01		10.0	7.56	6.55	5.99	5.64	5.39	5.20	5.06	4.94	4.85	4.71	4.56	4.41	4.25	4.08	4.00	3.91
.005		12.8	9.43	8.08	7.34	6.87	6.54	6.30	6.12	5.97	5.85	5.66	5.47	5.27	5.07	4.86	4.75	4.64
.10	12	3.18	2.81	2.61	2.48	2.39	2.33	2.28	2.24	2.21	2.19	2.15	2.10	2.06	2.01	1.96	1.93	1.90
.05		4.75	3.89	3.49	3.26	3.11	3.00	2.91	2.85	2.80	2.75	2.69	2.62	2.54	2.47	2.38	2.34	2.30
.025		6.55	5.10	4.47	4.12	3.89	3.73	3.61	3.51	3.44	3.37	3.28	3.18	3.07	2.96	2.85	2.79	2.72
.01		9.33	6.93	5.95	5.41	5.06	4.82	4.64	4.50	4.39	4.30	4.16	4.01	3.86	3.70	3.54	3.45	3.36
.005		11.8	8.51	7.23	6.52	6.07	5.76	5.52	5.35	5.20	5.09	4.91	4.72	4.53	4.33	4.12	4.01	3.90
.10	15	3.07	2.70	2.49	2.36	2.27	2.21	2.16	2.12	2.09	2.06	2.02	1.97	1.92	1.87	1.82	1.79	1.76
.05		4.54	3.68	3.29	3.06	2.90	2.79	2.71	2.64	2.59	2.54	2.48	2.40	2.33	2.25	2.16	2.11	2.07
.025		6.20	4.77	4.15	3.80	3.58	3.41	3.29	3.20	3.12	3.06	2.96	2.86	2.76	2.64	2.52	2.46	2.40
.01		8.68	6.36	5.42	4.89	4.56	4.32	4.14	4.00	3.89	3.80	3.67	3.52	3.37	3.21	3.05	2.96	2.87
.005		10.8	7.70	6.48	5.80	5.37	5.07	4.85	4.67	4.54	4.42	4.25	4.07	3.88	3.69	3.48	3.37	3.26

Table A -continued																		
.10	20	2.97	2.59	2.38	2.25	2.16	2.09	2.04	2.00	1.96	1.94	1.89	1.84	1.79	1.74	1.68	1.64	1.61
.05		4.35	3.49	3.10	2.87	2.71	2.60	2.51	2.45	2.39	2.35	2.28	2.20	2.12	2.04	1.95	1.90	1.84
.025		5.87	4.46	3.86	3.51	3.29	3.13	3.01	2.91	2.84	2.77	2.68	2.57	2.46	2.35	2.22	2.16	2.09
.01		8.10	5.85	4.94	4.43	4.10	3.87	3.70	3.56	3.46	3.37	3.23	3.09	2.94	2.78	2.61	2.52	2.42
.005		9.94	6.99	5.82	5.17	4.76	4.47	4.26	4.09	3.96	3.85	3.68	3.50	3.32	3.12	2.92	2.81	2.69
.10	30	2.88	2.49	2.28	2.14	2.05	1.98	1.93	1.88	1.85	1.82	1.77	1.72	1.67	1.61	1.54	1.50	1.46
.05		4.17	3.32	2.92	2.69	2.53	2.42	2.33	2.27	2.21	2.16	2.09	2.01	1.93	1.84	1.74	1.68	1.62
.025		5.57	4.18	3.59	3.25	3.03	2.87	2.75	2.65	2.57	2.51	2.41	2.31	2.20	2.07	1.94	1.87	1.79
.01		7.56	5.39	4.51	4.02	3.70	3.47	3.30	3.17	3.07	2.98	2.84	2.70	2.55	2.39	2.21	2.11	2.01
.005		9.18	6.35	5.24	4.62	4.23	3.95	3.74	3.58	3.45	3.34	3.18	3.01	2.82	2.63	2.42	2.30	2.18
.10	60	2.79	2.39	2.18	2.04	1.95	1.87	1.82	1.77	1.74	1.71	1.66	1.60	1.54	1.48	1.40	1.35	1.29
.05		4.00	3.15	2.76	2.53	2.37	2.25	2.17	2.10	2.04	1.99	1.92	1.84	1.75	1.65	1.53	1.47	1.39
.025		5.29	3.93	3.34	3.01	2.79	2.63	2.51	2.41	2.33	2.27	2.17	2.06	1.94	1.82	1.67	1.58	1.48
.01		7.08	4.98	4.13	3.65	3.34	3.12	2.95	2.82	2.72	2.63	2.50	2.35	2.20	2.03	1.84	1.73	1.60
.005		8.49	5.80	4.73	4.14	3.76	3.49	3.29	3.13	3.01	2.90	2.74	2.57	2.39	2.19	1.96	1.83	1.69
.10	120	2.75	2.35	2.13	1.99	1.90	1.82	1.77	1.72	1.68	1.65	1.60	1.54	1.48	1.41	1.32	1.26	1.19
.05		3.92	3.07	2.68	2.45	2.29	2.18	2.09	2.02	1.96	1.91	1.83	1.75	1.66	1.55	1.43	1.35	1.25
.025		5.15	3.80	3.23	2.89	2.67	2.52	2.39	2.30	2.22	2.16	2.05	1.94	1.82	1.69	1.63	1.43	1.31
.01		6.85	4.79	3.95	3.48	3.17	2.96	2.79	2.66	2.56	2.47	2.34	2.19	2.03	1.86	1.66	1.53	1.38
.005		8.18	5.54	4.50	3.92	3.55	3.28	3.09	2.93	2.81	2.71	2.54	2.37	2.19	1.98	1.75	1.61	1.43
.10	$\infty$	2.71	2.30	2.08	1.94	1.85	1.77	1.72	1.67	1.63	1.60	1.55	1.49	1.42	1.34	1.24	1.17	1.00
.05		3.84	3.00	2.60	2.37	2.21	2.10	2.01	1.94	1.88	1.83	1.75	1.67	1.57	1.46	1.32	1.22	1.00
.025		5.02	3.69	3.12	2.79	2.57	2.41	2.29	2.19	2.11	2.05	1.94	1.83	1.71	1.57	1.39	1.27	1.00
.01		6.63	4.61	3.78	3.32	3.02	2.80	2.64	2.51	2.41	2.32	2.18	2.04	1.88	1.70	1.47	1.32	1.00
.005		7.88	5.30	4.28	3.72	3.35	3.09	2.90	2.74	2.62	2.52	2.36	2.19	2.00	1.79	1.53	1.36	1.00

$\lambda$ or np	<b>Table B Some values of CDF of Poisson Distribution</b> $\Pr(X \leq k)$														
	k														
	0	1	2	3	4	5	6	7	8	9	10	11	12	13	14
0.01	0.990	1.000	1.000	1.000	1.000	1.000	1.000	1.000	1.000	1.000	1.000	1.000	1.000	1.000	1.000
0.10	0.905	0.995	1.000	1.000	1.000	1.000	1.000	1.000	1.000	1.000	1.000	1.000	1.000	1.000	1.000
0.20	0.819	0.982	0.999	1.000	1.000	1.000	1.000	1.000	1.000	1.000	1.000	1.000	1.000	1.000	1.000
0.30	0.741	0.963	0.996	1.000	1.000	1.000	1.000	1.000	1.000	1.000	1.000	1.000	1.000	1.000	1.000
0.40	0.670	0.938	0.992	0.999	1.000	1.000	1.000	1.000	1.000	1.000	1.000	1.000	1.000	1.000	1.000
0.80	0.449	0.809	0.953	0.991	0.999	1.000	1.000	1.000	1.000	1.000	1.000	1.000	1.000	1.000	1.000
1.00	0.368	0.736	0.920	0.981	0.996	0.999	1.000	1.000	1.000	1.000	1.000	1.000	1.000	1.000	1.000
2.00	0.135	0.406	0.677	0.857	0.947	0.983	0.995	0.999	1.000	1.000	1.000	1.000	1.000	1.000	1.000
3.00	0.050	0.199	0.423	0.647	0.815	0.916	0.966	0.988	0.996	0.999	1.000	1.000	1.000	1.000	1.000
4.00	0.018	0.092	0.238	0.433	0.629	0.785	0.889	0.949	0.979	0.992	0.997	0.999	1.000	1.000	1.000
5.00	0.007	0.040	0.125	0.265	0.440	0.616	0.762	0.867	0.932	0.968	0.990	0.995	0.998	0.999	1.000
6.00	0.002	0.017	0.062	0.151	0.285	0.446	0.606	0.744	0.847	0.916	0.960	0.980	0.991	0.996	0.999
6.20	0.002	0.015	0.054	0.134	0.259	0.414	0.574	0.716	0.826	0.902	0.950	0.975	0.989	0.995	0.998
6.40	0.002	0.012	0.042	0.110	0.225	0.384	0.540	0.697	0.802	0.886	0.940	0.968	0.986	0.994	0.997
6.60	0.001	0.010	0.040	0.105	0.212	0.355	0.511	0.658	0.780	0.860	0.920	0.962	0.982	0.992	0.997

$\lambda$ or np	<b>Table B Some values of CDF of Poisson Distribution</b> $\Pr(X \leq k)$														
	k														
	0	1	2	3	4	5	6	7	8	9	10	11	12	13	14
7.00	0.001	0.007	0.030	0.082	0.173	0.301	0.450	0.599	0.729	0.830	0.900	0.947	0.973	0.987	0.994
8.00	0.000	0.003	0.014	0.042	0.100	0.191	0.313	0.453	0.593	0.717	0.820	0.888	0.936	0.966	0.983
9.00	0.000	0.001	0.006	0.021	0.055	0.116	0.207	0.324	0.456	0.587	0.710	0.803	0.876	0.926	0.959
10.00	0.000	0.000	0.003	0.010	0.029	0.067	0.130	0.220	0.333	0.458	0.580	0.697	0.792	0.864	0.917
11.00	0.000	0.000	0.001	0.005	0.015	0.038	0.079	0.143	0.232	0.341	0.460	0.579	0.689	0.781	0.854
12.00	0.000	0.000	0.001	0.002	0.008	0.020	0.046	0.090	0.155	0.242	0.350	0.462	0.576	0.682	0.772
12.50	0.000	0.000	0.000	0.002	0.005	0.015	0.035	0.070	0.125	0.201	0.300	0.406	0.519	0.628	0.725
13.00	0.000	0.000	0.000	0.001	0.004	0.011	0.026	0.054	0.100	0.166	0.250	0.353	0.463	0.573	0.675
13.50	0.000	0.000	0.000	0.001	0.003	0.008	0.019	0.041	0.079	0.135	0.210	0.304	0.409	0.518	0.623
14.00	0.000	0.000	0.000	0.000	0.002	0.006	0.014	0.032	0.062	0.109	0.180	0.260	0.358	0.464	0.570
14.50	0.000	0.000	0.000	0.000	0.001	0.004	0.010	0.024	0.048	0.088	0.140	0.220	0.311	0.413	0.518
15.00	0.000	0.000	0.000	0.000	0.001	0.003	0.008	0.018	0.037	0.070	0.120	0.185	0.268	0.363	0.466
15.50	0.000	0.000	0.000	0.000	0.001	0.002	0.006	0.013	0.029	0.055	0.100	0.154	0.228	0.317	0.415
16.00	0.000	0.000	0.000	0.000	0.000	0.001	0.004	0.010	0.022	0.043	0.080	0.127	0.193	0.275	0.368
16.50	0.000	0.000	0.000	0.000	0.000	0.001	0.003	0.007	0.017	0.034	0.060	0.104	0.162	0.236	0.323
17.00	0.000	0.000	0.000	0.000	0.000	0.001	0.002	0.005	0.013	0.026	0.050	0.085	0.135	0.201	0.281
17.50	0.000	0.000	0.000	0.000	0.000	0.000	0.001	0.004	0.009	0.020	0.040	0.068	0.112	0.170	0.243
18.00	0.000	0.000	0.000	0.000	0.000	0.000	0.001	0.003	0.007	0.015	0.030	0.055	0.092	0.143	0.208

$\lambda$ or np	<b>Table B Some values of CDF of Poisson Distribution</b> $\Pr(X \leq k)$														
	k														
	0	1	2	3	4	5	6	7	8	9	10	11	12	13	14
18.50	0.000	0.000	0.000	0.000	0.000	0.000	0.001	0.002	0.005	0.012	0.020	0.044	0.075	0.119	0.177
19.00	<b>0.000</b>	<b>0.000</b>	<b>0.000</b>	<b>0.000</b>	<b>0.000</b>	<b>0.000</b>	<b>0.001</b>	<b>0.002</b>	<b>0.004</b>	<b>0.009</b>	<b>0.020</b>	<b>0.035</b>	<b>0.061</b>	<b>0.098</b>	<b>0.150</b>
19.50	<b>0.000</b>	<b>0.000</b>	<b>0.000</b>	<b>0.000</b>	<b>0.000</b>	<b>0.000</b>	<b>0.000</b>	<b>0.001</b>	<b>0.003</b>	<b>0.007</b>	<b>0.010</b>	<b>0.027</b>	<b>0.049</b>	<b>0.081</b>	<b>0.126</b>
20.00	<b>0.000</b>	<b>0.000</b>	<b>0.000</b>	<b>0.000</b>	<b>0.000</b>	<b>0.000</b>	<b>0.000</b>	<b>0.001</b>	<b>0.002</b>	<b>0.005</b>	<b>0.010</b>	<b>0.021</b>	<b>0.039</b>	<b>0.066</b>	<b>0.105</b>
20.50	<b>0.000</b>	<b>0.000</b>	<b>0.000</b>	<b>0.000</b>	<b>0.000</b>	<b>0.000</b>	<b>0.000</b>	<b>0.001</b>	<b>0.002</b>	<b>0.004</b>	<b>0.010</b>	<b>0.017</b>	<b>0.031</b>	<b>0.054</b>	<b>0.087</b>
21.00	<b>0.000</b>	<b>0.000</b>	<b>0.000</b>	<b>0.000</b>	<b>0.000</b>	<b>0.000</b>	<b>0.000</b>	<b>0.000</b>	<b>0.001</b>	<b>0.003</b>	<b>0.010</b>	<b>0.013</b>	<b>0.025</b>	<b>0.043</b>	<b>0.072</b>
21.50	<b>0.000</b>	<b>0.000</b>	<b>0.000</b>	<b>0.000</b>	<b>0.000</b>	<b>0.000</b>	<b>0.000</b>	<b>0.000</b>	<b>0.001</b>	<b>0.002</b>	<b>0.005</b>	<b>0.010</b>	<b>0.019</b>	<b>0.035</b>	<b>0.059</b>
22.00	<b>0.000</b>	<b>0.000</b>	<b>0.000</b>	<b>0.000</b>	<b>0.000</b>	<b>0.000</b>	<b>0.000</b>	<b>0.000</b>	<b>0.001</b>	<b>0.002</b>	<b>0.004</b>	<b>0.008</b>	<b>0.015</b>	<b>0.028</b>	<b>0.048</b>
22.50	<b>0.000</b>	<b>0.000</b>	<b>0.000</b>	<b>0.000</b>	<b>0.000</b>	<b>0.000</b>	<b>0.000</b>	<b>0.000</b>	<b>0.000</b>	<b>0.001</b>	<b>0.003</b>	<b>0.006</b>	<b>0.012</b>	<b>0.022</b>	<b>0.039</b>
23.00	<b>0.000</b>	<b>0.000</b>	<b>0.000</b>	<b>0.000</b>	<b>0.000</b>	<b>0.000</b>	<b>0.000</b>	<b>0.000</b>	<b>0.000</b>	<b>0.001</b>	<b>0.002</b>	<b>0.004</b>	<b>0.009</b>	<b>0.017</b>	<b>0.031</b>
23.50	<b>0.000</b>	<b>0.000</b>	<b>0.000</b>	<b>0.000</b>	<b>0.000</b>	<b>0.000</b>	<b>0.000</b>	<b>0.000</b>	<b>0.000</b>	<b>0.001</b>	<b>0.002</b>	<b>0.003</b>	<b>0.007</b>	<b>0.014</b>	<b>0.025</b>
24.00	<b>0.000</b>	<b>0.000</b>	<b>0.000</b>	<b>0.000</b>	<b>0.000</b>	<b>0.000</b>	<b>0.000</b>	<b>0.000</b>	<b>0.000</b>	<b>0.000</b>	<b>0.001</b>	<b>0.003</b>	<b>0.005</b>	<b>0.011</b>	<b>0.020</b>
24.50	<b>0.000</b>	<b>0.000</b>	<b>0.000</b>	<b>0.000</b>	<b>0.000</b>	<b>0.000</b>	<b>0.000</b>	<b>0.000</b>	<b>0.000</b>	<b>0.000</b>	<b>0.001</b>	<b>0.002</b>	<b>0.004</b>	<b>0.008</b>	<b>0.016</b>

Table C Area under standard normal curve ( $\Pr(Z < z)$ ) e.g.  $\Pr(Z < -3.00) = 0.0013$

$z = \frac{x - \mu}{\sigma}$										
	0.09	0.08	0.07	0.06	0.05	0.04	0.03	0.02	0.01	0.00
-3.5	0.00017	0.00017	0.00018	0.00019	0.00019	0.0002	0.00021	0.00022	0.00022	0.00023
-3.4	0.00024	0.00025	0.00026	0.00027	0.00028	0.00029	0.0003	0.00031	0.00032	0.00034
-3.3	0.00035	0.00036	0.00038	0.00039	0.0004	0.00042	0.00043	0.00045	0.00047	0.00048
-3.2	0.0005	0.00052	0.00054	0.00056	0.00058	0.0006	0.00062	0.00064	0.00066	0.00069
-3.1	0.00071	0.00074	0.00076	0.00079	0.00082	0.00084	0.00087	0.0009	0.00094	0.00097
-3	0.001	0.00104	0.00107	0.00111	0.00114	0.00118	0.00122	0.00126	0.00131	0.00135
-2.9	0.00139	0.00144	0.00149	0.00154	0.00159	0.00164	0.00169	0.00175	0.00181	0.00187
-2.8	0.00193	0.00199	0.00205	0.00212	0.00219	0.00226	0.00233	0.0024	0.00248	0.00256
-2.7	0.00264	0.00272	0.0028	0.00289	0.00298	0.00307	0.00317	0.00326	0.00336	0.00347
-2.6	0.00357	0.00368	0.00379	0.00391	0.00402	0.00415	0.00427	0.0044	0.00453	0.00466
-2.5	0.0048	0.00494	0.00508	0.00523	0.00539	0.00554	0.0057	0.00587	0.00604	0.00621
-2.4	0.00639	0.00657	0.00676	0.00695	0.00714	0.00734	0.00755	0.00776	0.00798	0.0082
-2.3	0.00842	0.00866	0.00889	0.00914	0.00939	0.00964	0.0099	0.01017	0.01044	0.01072
-2.2	0.01101	0.01130	0.0116	0.01191	0.01222	0.01255	0.01287	0.01321	0.01355	0.01390
-2.1	0.01426	0.01463	0.015	0.01539	0.01578	0.01618	0.01659	0.01700	0.01743	0.01786
-2	0.01831	0.01876	0.01923	0.0197	0.02018	0.02068	0.02118	0.02169	0.02222	0.02275
-1.9	0.0233	0.02385	0.02442	0.025	0.02559	0.02619	0.0268	0.02743	0.02807	0.02872
-1.8	0.02938	0.03005	0.03074	0.03144	0.03216	0.03288	0.03362	0.03438	0.03515	0.03593
-1.7	0.03673	0.03754	0.03836	0.0392	0.04006	0.04093	0.04182	0.04272	0.04363	0.04457

Table C continued e.g. $\Pr(Z < -1.56) = 0.05938$										
Z	0.09	0.08	0.07	0.06	0.05	0.04	0.03	0.02	0.01	0.00
-1.6	0.04551	0.04648	0.04746	0.04846	0.04947	0.0505	0.05155	0.05262	0.0537	0.0548
-1.5	0.05592	0.05705	0.05821	0.05938	0.06057	0.06178	0.06301	0.06426	0.06552	0.06681
-1.4	0.06811	0.06944	0.07078	0.07215	0.07353	0.07493	0.07636	0.0778	0.07927	0.08076
-1.3	0.08226	0.08379	0.08534	0.08691	0.08851	0.09012	0.09176	0.09342	0.0951	0.0968
-1.2	0.09853	0.10027	0.10204	0.10383	0.10565	0.10749	0.10935	0.11123	0.11314	0.11507
-1.1	0.11702	0.119	0.121	0.12302	0.12507	0.12714	0.12924	0.13136	0.1335	0.13567
-1	0.13786	0.14007	0.14231	0.14457	0.14686	0.14917	0.15151	0.15386	0.15625	0.15866
-0.9	0.16109	0.16354	0.16602	0.16853	0.17106	0.17361	0.17619	0.17879	0.18141	0.18406
-0.8	0.18673	0.18943	0.19215	0.19489	0.19766	0.20045	0.20327	0.20611	0.20897	0.21186
-0.7	0.21476	0.2177	0.22065	0.22363	0.22663	0.22965	0.2327	0.23576	0.23885	0.24196
-0.6	0.2451	0.24825	0.25143	0.25463	0.25785	0.26109	0.26435	0.26763	0.27093	0.27425
-0.5	0.2776	0.28096	0.28434	0.28774	0.29116	0.2946	0.29806	0.30153	0.30503	0.30854
-0.4	0.31207	0.31561	0.31918	0.32276	0.32636	0.32997	0.3336	0.33724	0.3409	0.34458
-0.3	0.34827	0.35197	0.35569	0.35942	0.36317	0.36693	0.3707	0.37448	0.37828	0.38209
-0.2	0.38591	0.38974	0.39358	0.39743	0.40129	0.40517	0.40905	0.41294	0.41683	0.42074
-0.1	0.42465	0.42858	0.43251	0.43644	0.44038	0.44433	0.44828	0.45224	0.4562	0.46017
0	0.46414	0.46812	0.4721	0.47608	0.48006	0.48405	0.48803	0.49202	0.49601	0.5



$\frac{x-\mu}{\sigma}$ Z	Table C continued e.g. $\Pr(Z < 1.04) = 0.14917$									
	0	0.01	0.02	0.03	0.04	0.05	0.06	0.07	0.08	0.09
0	0.5	0.50399	0.50798	0.51197	0.51595	0.51994	0.52392	0.5279	0.53188	0.53586
0.1	0.53983	0.5438	0.54776	0.55172	0.55567	0.55962	0.56356	0.56749	0.57142	0.57535
0.2	0.57926	0.58317	0.58706	0.59095	0.59483	0.59871	0.60257	0.60642	0.61026	0.61409
0.3	0.61791	0.62172	0.62552	0.6293	0.63307	0.63683	0.64058	0.64431	0.64803	0.65173
0.4	0.65542	0.6591	0.66276	0.6664	0.67003	0.67364	0.67724	0.68082	0.68439	0.68793
0.5	0.69146	0.69497	0.69847	0.70194	0.7054	0.70884	0.71226	0.71566	0.71904	0.7224
0.6	0.72575	0.72907	0.73237	0.73565	0.73891	0.74215	0.74537	0.74857	0.75175	0.7549
0.7	0.75804	0.76115	0.76424	0.7673	0.77035	0.77337	0.77637	0.77935	0.7823	0.78524
0.8	0.78814	0.79103	0.79389	0.79673	0.79955	0.80234	0.80511	0.80785	0.81057	0.81327
0.9	0.81594	0.81859	0.82121	0.82381	0.82639	0.82894	0.83147	0.83398	0.83646	0.83891
1	0.84134	0.84375	0.84614	0.84849	0.85083	0.85314	0.85543	0.85769	0.85993	0.86214
1.1	0.86433	0.8665	0.86864	0.87076	0.87286	0.87493	0.87698	0.879	0.881	0.88298
1.2	0.88493	0.88686	0.88877	0.89065	0.89251	0.89435	0.89617	0.89796	0.89973	0.90147
1.3	0.9032	0.9049	0.90658	0.90824	0.90988	0.91149	0.91309	0.91466	0.91621	0.91774
1.4	0.91924	0.92073	0.9222	0.92364	0.92507	0.92647	0.92785	0.92922	0.93056	0.93189
1.5	0.93319	0.93448	0.93574	0.93699	0.93822	0.93943	0.94062	0.94179	0.94295	0.94408
1.6	0.9452	0.9463	0.94738	0.94845	0.9495	0.95053	0.95154	0.95254	0.95352	0.95449
1.7	0.95543	0.95637	0.95728	0.95818	0.95907	0.95994	0.9608	0.96164	0.96246	0.96327
1.8	0.96407	0.96485	0.96562	0.96638	0.96712	0.96784	0.96856	0.96926	0.96995	0.97062

Table C continued										
e.g. $\Pr(Z < 3.44) = 0.99971$										
Z	0.00	0.01	0.02	0.03	0.04	0.05	0.06	0.07	0.08	0.09
1.9	0.97128	0.97193	0.97257	0.9732	0.97381	0.97441	0.975	0.97558	0.97615	0.9767
2	0.97725	0.97778	0.97831	0.97882	0.97932	0.97982	0.9803	0.98077	0.98124	0.98169
2.1	0.98214	0.98257	0.983	0.98341	0.98382	0.98422	0.98461	0.985	0.98537	0.98574
2.2	0.9861	0.98645	0.98679	0.98713	0.98745	0.98778	0.98809	0.9884	0.9887	0.98899
2.3	0.98928	0.98956	0.98983	0.9901	0.99036	0.99061	0.99086	0.99111	0.99134	0.99158
2.4	0.9918	0.99202	0.99224	0.99245	0.99266	0.99286	0.99305	0.99324	0.99343	0.99361
2.5	0.99379	0.99396	0.99413	0.9943	0.99446	0.99461	0.99477	0.99492	0.99506	0.9952
2.6	0.99534	0.99547	0.9956	0.99573	0.99585	0.99598	0.99609	0.99621	0.99632	0.99643
2.7	0.99653	0.99664	0.99674	0.99683	0.99693	0.99702	0.99711	0.9972	0.99728	0.99736
2.8	0.99744	0.99752	0.9976	0.99767	0.99774	0.99781	0.99788	0.99795	0.99801	0.99807
2.9	0.99813	0.99819	0.99825	0.99831	0.99836	0.99841	0.99846	0.99851	0.99856	0.99861
3	0.99865	0.99869	0.99874	0.99878	0.99882	0.99886	0.99889	0.99893	0.99896	0.999
3.1	0.99903	0.99906	0.9991	0.99913	0.99916	0.99918	0.99921	0.99924	0.99926	0.99929
3.2	0.99931	0.99934	0.99936	0.99938	0.9994	0.99942	0.99944	0.99946	0.99948	0.9995
3.3	0.99952	0.99953	0.99955	0.99957	0.99958	0.9996	0.99961	0.99962	0.99964	0.99965
3.4	0.99966	0.99968	0.99969	0.9997	0.99971	0.99972	0.99973	0.99974	0.99975	0.99976
3.5	0.99977	0.99978	0.99978	0.99979	0.9998	0.99981	0.99981	0.99982	0.99983	0.99983

<b>Table D Critical values of standard normal (<math>Z_\alpha</math>)</b>										
e.g. $z_{0.05} = 1.64$										
$Z_\alpha$	0	0.01	0.02	0.03	0.04	0.05	0.06	0.07	0.08	0.09
0	0.5	0.49601	0.49202	0.48803	0.48405	0.48006	0.47608	0.4721	0.46812	0.46414
0.1	0.46017	0.4562	0.45224	0.44828	0.44433	0.44038	0.43644	0.43251	0.42858	0.42465
0.2	0.42074	0.41683	0.41294	0.40905	0.40517	0.40129	0.39743	0.39358	0.38974	0.38591
0.3	0.38209	0.37828	0.37448	0.3707	0.36693	0.36317	0.35942	0.35569	0.35197	0.34827
0.4	0.34458	0.3409	0.33724	0.3336	0.32997	0.32636	0.32276	0.31918	0.31561	0.31207
0.5	0.30854	0.30503	0.30153	0.29806	0.2946	0.29116	0.28774	0.28434	0.28096	0.2776
0.6	0.27425	0.27093	0.26763	0.26435	0.26109	0.25785	0.25463	0.25143	0.24825	0.2451
0.7	0.24196	0.23885	0.23576	0.2327	0.22965	0.22663	0.22363	0.22065	0.2177	0.21476
0.8	0.21186	0.20897	0.20611	0.20327	0.20045	0.19766	0.19489	0.19215	0.18943	0.18673
0.9	0.18406	0.18141	0.17879	0.17619	0.17361	0.17106	0.16853	0.16602	0.16354	0.16109
1	0.15866	0.15625	0.15386	0.15151	0.14917	0.14686	0.14457	0.14231	0.14007	0.13786
1.1	0.13567	0.1335	0.13136	0.12924	0.12714	0.12507	0.12302	0.121	0.119	0.11702
1.2	0.11507	0.11314	0.11123	0.10935	0.10749	0.10565	0.10383	0.10204	0.10027	0.09853
1.3	0.0968	0.0951	0.09342	0.09176	0.09012	0.08851	0.08691	0.08534	0.08379	0.08226
1.4	0.08076	0.07927	0.0778	0.07636	0.07493	0.07353	0.07215	0.07078	0.06944	0.06811
1.5	0.06681	0.06552	0.06426	0.06301	0.06178	0.06057	0.05938	0.05821	0.05705	0.05592
1.6	0.0548	0.0537	0.05262	0.05155	0.0505	0.04947	0.04846	0.04746	0.04648	0.04551

Table D Critical values of standard normal continued e.g for $\alpha = 0.05$ $z_{\frac{\alpha}{2}} = z_{0.025} = 1.96$										
$Z_{\alpha}$	0	0.01	0.02	0.03	0.04	0.05	0.06	0.07	0.08	0.09
1.8	0.03593	0.03515	0.03438	0.03362	0.03288	0.03216	0.03144	0.03074	0.03005	0.02938
1.9	0.02872	0.02807	0.02743	0.0268	0.02619	0.02559	0.025	0.02442	0.02385	0.0233
2	0.02275	0.02222	0.02169	0.02118	0.02068	0.02018	0.0197	0.01923	0.01876	0.01831
2.1	0.01786	0.01743	0.017	0.01659	0.01618	0.01578	0.01539	0.015	0.01463	0.01426
2.2	0.0139	0.01355	0.01321	0.01287	0.01255	0.01222	0.01191	0.0116	0.0113	0.01101
2.3	0.01072	0.01044	0.01017	0.0099	0.00964	0.00939	0.00914	0.00889	0.00866	0.00842
2.4	0.0082	0.00798	0.00776	0.00755	0.00734	0.00714	0.00695	0.00676	0.00657	0.00639
2.5	0.00621	0.00604	0.00587	0.0057	0.00554	0.00539	0.00523	0.00508	0.00494	0.0048
2.6	0.00466	0.00453	0.0044	0.00427	0.00415	0.00402	0.00391	0.00379	0.00368	0.00357
2.7	0.00347	0.00336	0.00326	0.00317	0.00307	0.00298	0.00289	0.0028	0.00272	0.00264
2.8	0.00256	0.00248	0.0024	0.00233	0.00226	0.00219	0.00212	0.00205	0.00199	0.00193
2.9	0.00187	0.00181	0.00175	0.00169	0.00164	0.00159	0.00154	0.00149	0.00144	0.00139
3	0.00135	0.00131	0.00126	0.00122	0.00118	0.00114	0.00111	0.00107	0.00104	0.001

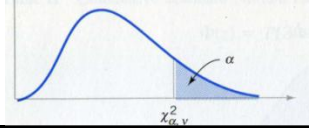

**Table E Critical values of Chi<sup>2</sup> Distribution( $\chi^2_{\alpha, v}$ )**

$\nu$	$\alpha$											
	.001	.005	.010	.025	.050	.100	.900	.950	.975	.990	.995	.999
1	1.83	7.88	6.63	5.02	3.84	2.71	0.02	0.00	0.00	0.00	0.00	0.00
2	13.82	10.60	9.21	7.38	5.99	4.61	0.21	0.10	0.05	0.02	0.01	0.00
3	16.27	12.84	11.34	9.35	7.81	6.25	0.58	0.35	0.22	0.11	0.07	0.02
4	18.47	14.86	13.28	11.14	9.49	7.78	1.06	0.71	0.48	0.30	0.21	0.09
5	20.52	16.75	15.09	12.83	11.07	9.24	1.61	1.15	0.83	0.55	0.41	0.21
6	22.46	18.55	16.81	14.45	12.59	10.64	2.20	1.64	1.24	0.87	0.68	0.38
7	24.32	20.28	18.48	16.01	14.07	12.02	2.83	2.17	1.69	1.24	0.99	0.60
8	26.13	21.95	20.09	17.53	15.51	13.36	3.49	2.73	2.18	1.65	1.34	0.86
9	27.88	23.59	21.67	19.02	16.92	14.68	4.17	3.33	2.70	2.09	1.73	1.15
10	29.59	25.19	23.21	20.48	18.31	15.99	4.87	3.94	3.25	2.56	2.16	1.48
11	31.26	26.76	24.72	21.92	19.68	17.28	5.58	4.57	3.82	3.05	2.60	1.83
12	32.91	28.30	26.22	23.34	21.03	18.55	6.30	5.23	4.40	3.57	3.07	2.21
13	34.53	29.82	27.69	24.74	22.36	19.81	7.04	5.89	5.01	4.11	3.57	2.62
14	36.12	31.32	29.14	26.12	23.68	21.06	7.79	6.57	5.63	4.66	4.07	3.04
15	37.70	32.80	30.58	27.49	25.00	22.31	8.55	7.26	6.26	5.23	4.60	3.48
16	39.25	34.27	32.00	28.85	26.30	23.54	9.31	7.96	6.91	5.81	5.14	3.94

Table E continued

$\alpha$ $v$	.001	.005	.010	.025	.050	.100	.900	.950	.975	.990	.995	.999
17	4.79	35.72	33.41	30.19	27.59	24.77	10.09	8.67	7.56	6.41	5.70	4.42
18	42.31	37.16	34.81	31.53	28.87	25.99	10.86	9.39	8.23	7.01	6.26	4.91
19	43.82	38.58	36.19	32.85	30.14	27.20	11.65	10.12	8.91	7.63	6.84	5.41
20	45.32	40.00	37.57	34.17	31.41	28.41	2.44	10.85	9.59	8.26	7.43	5.92
21	46.80	41.40	38.93	35.48	32.67	29.62	13.24	11.59	10.28	8.90	8.03	6.45
22	48.27	42.80	40.29	36.78	33.92	30.81	14.04	12.34	10.98	9.54	8.64	6.98
23	49.73	44.18	41.64	38.08	35.17	32.01	14.85	13.09	11.69	10.20	9.26	7.53
24	51.18	45.56	42.98	39.36	36.42	33.20	15.66	13.85	12.40	1.86	9.89	8.09
25	52.62	46.93	44.31	40.65	37.65	34.38	16.47	14.61	13.12	11.52	10.52	8.65
26	54.05	48.29	45.64	41.92	38.89	35.56	17.29	15.38	13.84	12.20	11.16	9.22
27	55.47	49.64	46.96	43.19	40.11	36.74	18.11	16.15	14.57	12.88	11.81	9.80
28	56.89	50.99	48.28	44.46	41.34	37.92	18.94	16.93	15.31	13.56	12.46	10.39
29	58.30	52.34	49.59	45.72	42.56	39.09	19.77	17.71	16.05	14.26	13.12	10.99
30	59.70	53.67	50.89	46.98	43.77	40.26	20.60	18.49	16.79	14.95	13.79	11.59
40	73.40	66.77	63.69	59.34	55.76	51.81	29.05	26.51	24.43	22.16	20.71	17.92
50	86.67	79.49	76.15	71.42	67.50	63.17	37.69	34.76	32.36	29.71	27.99	24.67
60	99.61	91.95	88.38	83.30	79.08	74.40	46.46	43.19	40.48	37.48	35.53	31.74
70	112.32	104.21	100.43	95.02	90.53	85.53	55.33	51.74	48.76	45.44	43.28	39.04
80	124.84	116.32	112.33	106.63	101.88	96.58	64.28	60.39	57.15	53.54	51.17	46.52
90	137.20	128.30	124.12	118.14	113.15	107.57	73.29	69.13	65.65	61.75	59.20	54.16
100	149.45	140.17	135.81	129.56	124.34	118.50	82.36	77.93	74.22	70.06	67.33	61.92

<b>Table F Characteristic of some continuous distributions</b>				
	pdf	MGF	Mean	Variance
<b>Uniform (a,b)</b>	$\frac{1}{b-a}, a < x < b$	$\varphi(t) = \frac{e^{tb} - e^{ta}}{t(b-a)}$	$\frac{(a+b)}{2}$	$\frac{(b-a)^2}{12}$
<b>Exponential with Parameter <math>\lambda</math></b>	$\lambda e^{-\lambda x}, x \geq 0$	$\frac{\lambda}{\lambda - t}$	$\frac{1}{\lambda}$	$\frac{1}{\lambda^2}$
<b>Gamma(n, <math>\lambda</math>) n integer, <math>\lambda &gt; 0</math></b>	$\frac{\lambda e^{-\lambda x} (\lambda x)^{n-1}}{(n-1)!}, x \geq 0$	$\left(\frac{\lambda}{\lambda - t}\right)^n$	$\frac{n}{\lambda}$	$\frac{n}{\lambda^2}$
<b>Normal(<math>\mu, \sigma</math>)</b>	$\frac{1}{\sigma\sqrt{2\pi}} e^{-\frac{(x-\mu)^2}{2\sigma^2}} \quad -\infty < x < \infty$	$\exp\left(\mu t + \frac{\sigma^2 t^2}{2}\right)^n$	$\mu$	$\sigma^2$
<b>Lognormal (<math>\mu, \sigma</math>)</b>	$\frac{1}{\sigma t \sqrt{2\pi}} e^{-\frac{(\ln t - \mu)^2}{2\sigma^2}} \quad t \geq 0$		$\exp\left(\mu + \frac{\sigma^2}{2}\right)$	$e^{2\mu + \sigma^2} \times (e^{\sigma^2} - 1)$
<b>Beta with parameters <math>a &gt; 0, b &gt; 0</math></b>	$c x^{a-1} (1-x)^{b-1}, 0 < x < 1 \quad c = \frac{\Gamma(a+b)}{\Gamma(a)\Gamma(b)}$		$\frac{a}{a+b}$	$\frac{a \times b}{(a+b)^2 (a+b+1)}$





<b>Table F Characteristic of some continuous distributions</b> continued A= location parameter B= scale parameter C= shape parameter				
Variance	mean	CDF	pdf	
$B^2 \Gamma(1+\frac{2}{C}) + B^2 (\Gamma(1+\frac{1}{C}))^2$	$A + B\Gamma(1+\frac{1}{C})$	$1 - e^{-\left(\frac{x-A}{B}\right)^C} \quad x \geq A$	$\frac{C}{B} \left(\frac{x-A}{B}\right)^{C-1} e^{-\left(\frac{x-A}{B}\right)^C} \quad x \geq A$	Weibull
	$A + \frac{B}{1-C}$	$1 - (1 + C \times \frac{x-A}{B})^{-\frac{1}{C}}$ valid on $A < x < \infty$ when $C \geq 0$ or $A < x < A - \frac{B}{C}$ when $C < 0$	$\frac{1}{B} (1 + C \frac{x-A}{B})^{-\frac{1}{C}}$ valid on $A < x < \infty$ when $C \geq 0$ or $A < x < A - \frac{B}{C}$ when $C < 0$	GPD
		$\begin{cases} 0 & x < A + \frac{B}{C} \quad \& C < 0 \\ e^{-\left(1 - C \times \frac{x-A}{B}\right)^{\frac{1}{C}}} & \\ 1 & x > A + \frac{B}{C} \quad \& C > 0 \end{cases}$	$\begin{cases} 0 & x < A + \frac{B}{C} \quad \& C < 0 \\ \left(1 - C \frac{x-A}{B}\right)^{\frac{1}{C}-1} \times e^{-\left(1 - C \frac{x-A}{B}\right)^{\frac{1}{C}}} & \\ 1 & x > A + \frac{B}{C} \quad \& C > 0 \end{cases}$ for $\begin{cases} x \geq A + \frac{B}{C} \quad \& C < 0 \\ x \leq A + \frac{B}{C} \quad \& C > 0 \end{cases}$	GEV
$\frac{\pi^2 B^2}{6}$	$A + \gamma B$ $\gamma = 0.05772$	$e^{-e^{-\frac{x-A}{B}}}$	$\frac{1}{B} \exp\left(-\frac{x-A}{B} - e^{-\frac{x-A}{B}}\right)$	FT1
A Weibull distribution with A= 0 & C=1 is an exponential distribution. A Weibull distribution with A= 0 & C=2 is Rayleigh distribution A GPD distribution with A= 0 & C=0 is an exponential distribution				

<b>Table G Characteristic of some discrete distributions</b>					
	Probability function p(x)	MGF	Z-transform	mean	Variance
Binomial (n,p), $0 \leq p \leq 1$	$\binom{n}{x} p^x (1-p)^{n-x} \quad x = 0, 1, \dots, n$	$[pe^t + (1-p)]^n$	$[pz + (1-p)]^n$	$np$	$np(1-p)$
Poisson with parameter $\lambda$	$e^{-\lambda} \frac{\lambda^x}{x!} \quad x = 0, 1, 2, \dots$	$\exp[\lambda(e^t - 1)]$	$e^{\lambda(z-1)}$	$\lambda$	$\lambda$
Geometric for success with parameter $0 \leq p \leq 1$	$p(1-p)^{x-1} \quad x = 1, 2, \dots$	$\frac{pe^t}{1-(1-p)e^t}$	$\frac{pz}{1-(1-p)z}$	$\frac{1}{p}$	$\frac{1-p}{p^2}$
Geometric for failure with parameter $0 \leq p \leq 1$	$p(1-p)^x \quad x = 0, 1, 2, \dots$	$\frac{p}{1-(1-p)e^t}, \quad t < -\ln(1-p)$	$\frac{p}{1-(1-p)z}$	$\frac{1-p}{p}$	$\frac{1-p}{p^2}$

**Table H MATLAB<sup>1</sup> Commands related to Distributions**

Distribution	Parameter estimator	Random numbers	Inverse of CDF	CDF(F(x))	Density/probability function
Beta	betafit(X)	betarnd(A,B,m,n,o,...)	betainv(P,A,B)	betacdf(x,A,B)	betapdf(x,A,B)
Poisson	poissfit(X)	poissrnd( $\lambda$ ,m,n)	poissinv(P, $\lambda$ )	poisscdf(x, $\lambda$ )	poisspdf(x, $\lambda$ )
Binomial	binofit(X,n)	binornd(N,P,m,n)	binoinv(Y,N,P)	binocdf(x,N,P)	binopdf(x,N,P)
Neg Bino.	nbinfit(X)	nbinrnd(R,P,m,n)	nbininv(Y,R,P)	nbincdf(x,R,P)	nbinpdf(x,R,P)
Hyp. Geo.		hygernd(M,K,N,m,n)	hygeinv(P,M,K,N)	hygecdf(x,M,K,N)	hygepdf(x,M,K,N)
Gamma	gamfit(X)	gamrnd(n, $\lambda$ ,m,n)	gaminv(P, n, $\lambda$ )	gamcdf(x, n, $\lambda$ )	gampdf(x,n, $\lambda$ )
Lognormal	lognfit(X)	lognrnd( $\mu$ , $\sigma$ ,m,n)	logninv(P, $\mu$ , $\sigma$ )	logncdf(x, $\mu$ , $\sigma$ )	lognpdf(x, $\mu$ , $\sigma$ )
Chi-Squa..		chi2rnd(V,m,n)	chi2inv(P,V)	chi2cdf(x,V)	chi2pdf(x,V)
Normal	normfit(X)	normrnd( $\mu$ , $\sigma$ ,m,n)	norminv(P, $\mu$ , $\sigma$ )	normcdf(x $\mu$ , $\sigma$ )	normpdf(x, $\mu$ , $\sigma$ )
Exponential	expfit(X)	exprnd(mu,m,n)	expinv(P,mu)	expcdf(x, mu)	exppdf(x, mu)
Geometry		geornd(P,m,n)	geoinv(Y,P)	geocdf(x,P)	geopdf(x,P)
Weibull	wblfit(X)	wblrnd(B,C,m,n)	wblinv(P, B,C)	wblcdf(x, B,C)	wblpdf(x-A, B,C)
Uniform	unifit(X)	unifrnd(A,B,m,n)	unifinv(P,A,B)	unifcdf(x,A,B)	unifpdf(x,A,B)
F		frnd(V1,V2,m,n)	finv(P, V1,V2)	fcdf(x, V1,V2)	fpdf(x, V1,V2)
GEV	gevfit(X)	gevrnd(C,B,A)	gevinv (P,C,B,A)	gevcdf(x,C,B,A)	gevpdf(C,B,A)
GPD	gpdfit	gprnd	gpinv	gpcdf	gppdf
Rayleigh	raylfit(X)	raylrnd(B,m,n)	raylinv(P,B)	raylcdf(x,B)	raylpdf(x,B)
t		trnd(V,m,n)	tinv(P,V)	tcdf(x,V)	tpdf(x,V)

---

<sup>1</sup>Prepared by by: Mr Mohsen Abyar : A graduate of Shahid Bahonar University of Kerman, Iran

## ABOUT THE AUTHOR

The author received his B.S. in Industrial Engineering (IE) from a University of Technology in Tehran, in 1976 and his MS degree in IE from University of Pittsburgh(Pitt) ,PA in 1978. He was employed as a faculty member in Kerman, Iran in 1979. He started to continue his studies for PhD at Pitt in 1985; after 2 semesters he left USA for home; however he received PhD from Brunel University of London in July 2006. He has taught some courses for over 30 years

The author has published some textbooks in Persian; some articles in conferences and journals and supervised several graduate theses. He was retired in 2015 from his job as a faculty member at a university in his hometown Kerman, Iran. Chairman of IE and ME departments are among his responsibilities at the College of Engineering of Shahid Bahonar University of Kerman , Iran.

If youth but knew, If old age but could,

Si jeunesse savait, Si vieillesse pouvait  
(French Proverb)



دانشکده فنی دانشگاه شهید باهنر کرمان

College of Engineering, Shahid Bahonar University of Kerman, Iran