



Woodworking Machinery

Woodworking Machinery

SANDRA CARR



Woodworking Machinery Copyright © by Sandra Carr is licensed under a [Creative Commons Attribution 4.0 International License](https://creativecommons.org/licenses/by/4.0/), except where otherwise noted.

Contents

Part I. [Introduction](#)

Part II. [Table Saw](#)

1. Table Saw Safety	9
2. Parts of the Table Saw	13
3. Tooling and Blade Selection	29
4. Common Operations	42
5. Set Up and Maintenance	62

Part III. [Jointer](#)

6. Parts of the Jointer	75
7. Tooling	84
8. Use of the Jointer	87
9. Common Operations	94
10. Set up and Maintenance	103

Part IV. [Thickness Planer](#)

11. Parts of the Planer	111
12. Use of the Planer	117
13. Common Operations	120
14. Set Up and Maintenance	121

Part V. [Band Saw](#)

15. Parts of the Band Saw	129
16. Tooling	138
17. Use of the Band Saw	142
18. Common Operations	144
19. Set Up and Maintenance	155
20. Parts of the Drill Press	161
21. Tooling	164
22. Use of the Drill Press	165
23. Common Operations	166

24. Set Up and Maintenance

167

Appendix

169

PART I

INTRODUCTION

Modern woodworking shops rely on machines for every aspect of production, from initial cutting of raw lumber and panel products to joinery and assembly. While the size and focus of every shop is different, there is machinery that is commonly used in most. This resource aims to provide an overview of these machines, including their basic purpose and function, tooling, set-up, maintenance, and safe operation. Additionally, there is specific information on using the machines to perform a variety of common cutting and joinery operations.

Safety

Woodworking machines must be used safely as potential for injury is inherent in every operation. Understanding the mechanics of how the machine operates will aid you in preventing accidents. A spinning saw blade, drill, or router bit acts in a predictable way — once you understand the forces involved. Always have adequate training before attempting to use any piece of machinery and always use best practices for safe operation to ensure both you and those around you remain accident free.

Before using any machinery, ensure you have the correct personal protective equipment (PPE). For all the tools covered in this book, hearing and eye protection must be used.

Make sure to review the current [WorkSafeBC policies, regulations and guidelines](#) for workers.

General Safety Guidelines

While every machine has specific safety rules, these are applicable to all machinery and equipment.

- Never operate any tool or machine unless you are confident you know how to safely operate it.
- Some machine operations generate fine dust particulate that is not adequately cleared by the dust extraction system. Use an approved dust mask or respirator.
- Wear shop appropriate clothing that will not have the potential to come in contact with any moving parts.
- Tie back long hair.
- Do not wear gloves except for handling materials in the shop as they can be caught in the machinery and pull your hands into blades and feed mechanisms.
- Do not distract another person operating a machine — wait until they power off the equipment and all motion has stopped. Do not leave a machine until it has come to a complete stop.
- Keep machine tables clear of clutter and debris.
- Keep machines cleared of sawdust and chips as they are combustible and a fire hazard.
- Inspect all machinery before using to confirm engineering controls for safety are in place. These could include dust collection, guards, splitters on table saws, and anti-kickback devices.
- Plan your movement around the shop environment for safety. Do not walk through potential **kickback** hazard zones and keep a safe distance from machinery that is in use.
- Ensure any machine's power source is locked out before changing cutters. View the WorkSafe BC video below.



One or more interactive elements has been excluded from this version of the text. You can view them online here: <https://pressbooks.bccampus.ca/woodworkingmachinery/?p=3#video-3-1>

PART I

TABLE SAW

The table saw is one of the most used machines in the shop. Its versatility makes it indispensable for machining both solid lumber and composite materials such as plywoods and MDF. Table saws are used for stock preparation and sizing. Plywood and composite materials are easily cut to accurate final sizes, solid wood may be resawn, ripped to width, or crosscut to length. The table saw excels at a variety of joinery operations from finger joints to mitres to dado/rabbit joints. Shaping operations are also possible, including cutting circles, bevels, and even cove mouldings.

Table saws are often designated by the maximum diameter of blade it can accommodate. Typical cabinet saws use a 250mm/10 inch diameter blade, while larger industrial sliding table saws typically use a 300mm/12 inch or larger blade. The maximum width of rip cut is another important designation. A larger capacity rip cut makes breaking down full sheets of plywood easier.

Types of table saws

Portable or Jobsite

Portable or jobsite table saws are small and lightweight, making them ideal for tasks such as on-site installation work. They are manufactured with lighter weight materials such as aluminum and plastics. These saws are easily transported and set-up, and are placed on saw horses or a work table. Some models have a folding base with wheels. They are powered with standard 110 volt household electricity. Because they have small motors, they do not handle heavy cutting and most have a small rip capacity.

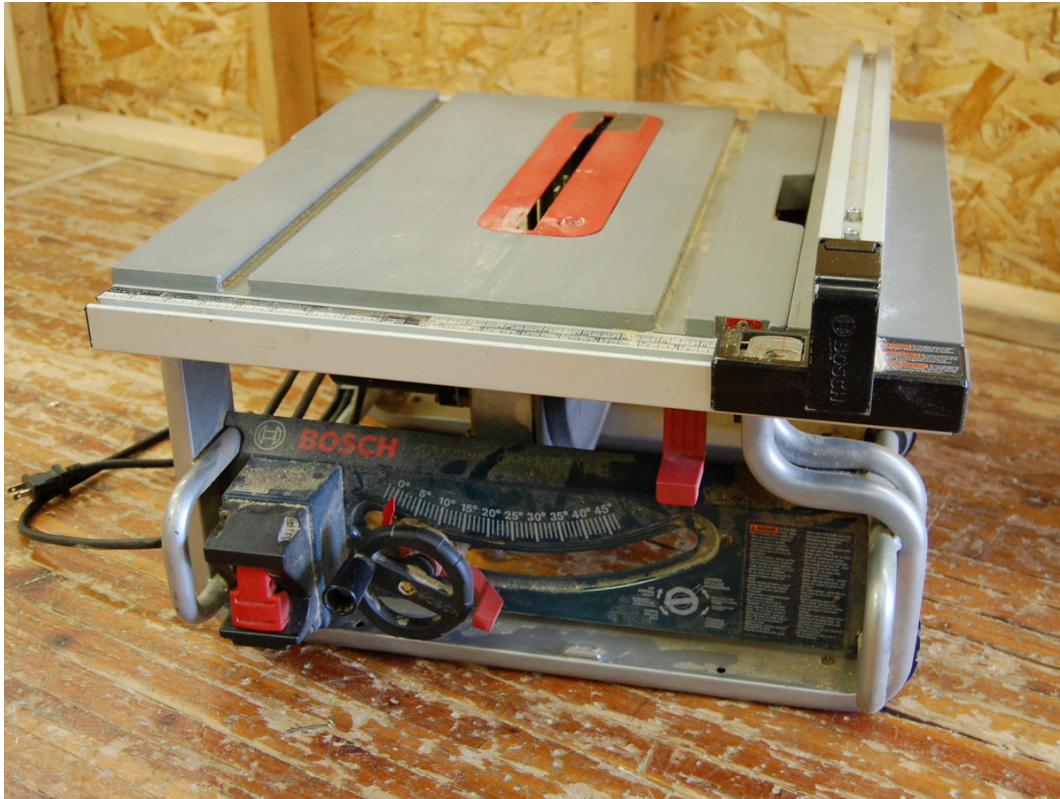

*A portable or
benchtop table saw*

Contractor

Contractor saws are larger than portable saws and are not usually transported to a job site, having been replaced by modern portable models. They are differentiated from a cabinet saw (described below) by the design of the saw base and the smaller motor. Contractor saws have an open-type base with legs; typically the motor hangs out of the back of the saw. Because of this design, dust collection tends to be difficult. The motors range in horsepower from 1.5 to 1.75, and may run on 120 volt or 240 volt electricity. Some models of these saws have features common to larger cabinet saws, including a quality rip fence and cast iron table. While they may be adequate for many joinery tasks, they can be underpowered when cutting through thick stock or hardwoods.



Cabinet

Cabinet saws are characterized by having larger, more powerful motors, a completely enclosed base, and robust construction. Motor size is typically 3 or 5 horsepower, with 5 horsepower models common. These saws run on a 240 voltage, which means a cooler running motor less likely to overheat. The motor is contained within the closed cabinet which allows for more efficient dust collection and keeps the internal components guarded. Cabinet saws have rip capacities up to 1350mm or 53 inches. A larger rip capacity is desirable when cutting large parts.

A cabinet saw with typical outfeed and right side extension tables



Panel Saw

Cutting sheet goods on a cabinet table saw is achievable, but limitations with capacity and the size and weight of many sheet goods make it less than ideal. Panel saws are designed to cut these materials with ease and accuracy. There are two kinds of panel saws, vertical and horizontal. Vertical saws take up less floor space and differ from horizontal models in that the panel stays stationary against stops while the blade and motor assembly move to complete the cut. Low cost vertical panel saws are often seen in hardware stores where they are used to rough cut customer material. Industrial vertical panel saws are used in large production facilities. They are highly accurate, can cut multiple sheets at once, have scoring capabilities, and are often computer numerically controlled (CNC).

The horizontal panel saw or sliding table saw is similar to a cabinet saw, but has a large sliding table on the left side of the saw blade. This type of saw is commonly found in cabinet and furniture shops as it has the versatility of a standard table saw as well as the ability to quickly and accurately cut sheet goods. The sliding table is designed to travel close to the blade, and has a long crosscutting fence with several moveable stops. The material to be cut is placed on the table and travels on it throughout the cut. Another feature found on panel saws is the addition of a scoring blade unit. This is a small secondary cutter that runs ahead of the main saw blade to score the bottom of veneered and melamine sheet goods that are prone to chipping.

A sliding table saw is often designated by the length of its table, which is related to the size of sheet goods it can cut. These saws are available with sliding tables that have a cutting capacity from 4 feet to 12 feet long. They usually have larger diameter blades, ranging from 315 mm to 400 mm or 12 to 16 inches.

*Sliding table saw or
panel saw*



1. Table Saw Safety

Any tool can be dangerous, however the nature of the table saw and its mechanics creates a higher potential for accidents. A 10 inch saw with the blade at maximum cutting depth has 3 inches blade exposed above the table. The same 10 inch table saw turns at about 225 km/h, presenting a high potential for injury. Unguarded cutters are necessary for many joinery operations, increasing the potential for accidents. The table saw is prone to kickbacks; understanding the conditions that cause them will reduce the possibility of them occurring. Always use the appropriate prevention measures and safeguards.

Guidelines for Safe Ripping

- Keep your hands away from the saw blade at all times, and use all appropriate guards and splitters.
- Use a push stick if the rip fence is set for a 6 inch / 150 mm or less cut.
- Always use the [correct blade](#) for the material and type of cut you are performing.
- Set the blade to the correct height, with the gullets no more than 6 mm or ¼ inch above the surface of the material.
- Use an appropriate feed rate. With thicker and/or denser stock use a slower feed rate to allow the saw to complete the cut. Feeding stock too quickly is dangerous.
- Feed the wood smoothly throughout the cut. Do not pull the work back out of a rip cut — it can catch the blade and kickback.
- Whenever possible, do not stand behind the workpiece in the kick back zone between the blade and the rip fence. Some operations such as cutting large pieces may require it.
- The material to be ripped must have one flat face and one straight edge. These flat and straight reference surfaces ensure the workpiece remains stable and in contact with the table throughout the cut.
- The material to be ripped must remain firmly in contact with the rip fence at all times. Stock losing contact with the rip fence and contacting the back of the saw blade just after the cut creates a high potential for a kickback.
- The length of the workpiece against the rip fence should be greater than the width of the cut. This length-to-width orientation creates stability as the material is pushed along the rip fence.
- Push the material through the saw until it clears the back of the blade. Failing to do so leaves the workpiece in the kickback zone.
- Do not use your left hand to push the offcut clear of the blade as you are cutting. If the piece kicks back, it can drag your hand through the blade.
- When the cut is complete, do not pick the workpiece up off the table and carry it over the spinning blade. If you drop it, it will kick back. It is acceptable to slide the piece on the table around the right side of the rip fence, then pick it up.
- Do not reach behind the blade unless it has come to a complete stop, the workpiece can catch and drag your hand through the blade.
- When ripping solid stock, be aware of knots, splits, or other defects in the material. Knots can come loose and be thrown back at the operator. Splits can be a clue for tension within a board that may close up and bind in the cut. When cutting these types of materials, a face shield is recommended. An alternative method is to use a bandsaw to cut the stock to rough width before using the table saw to cut to an accurate size.
- When moving around the shop environment, never walk behind a table saw that is being used for ripping.

If there is a kickback, you will be in the path of the projectile.

Also see [Common Operations: Ripping](#)

Guidelines for Safe Crosscutting

- Keep your hands away from the saw blade at all times, and use all appropriate guards and splitters.
- Always use the [correct blade](#) for the material and type of cut you are performing..
- Set the blade to the correct height, with the gullets no more than 6 mm or ¼ inch above the surface of the material.
- Use an appropriate feed rate. With thicker and/or denser stock use a slower feed rate to allow the saw to complete the cut. Feeding stock too quickly is dangerous.
- Use a fence, either the mitre gauge or a shop-made crosscut tray. A mitre gauge should be used with an auxiliary fence to adequately support the work. This also gives a cleaner cut as it creates zero clearance to the blade. A crosscut tray can better support larger work pieces. Shop-made trays can also provide zero clearance on the bottom and back of the cut. They are easier to set up for cutting multiple parts with a stop block than a mitre gauge.
- Hold or clamp parts that are trapped between the stop block and the blade throughout the entirety of the cut. Any piece that is trapped between the fence and the blade has the potential to kick back.
- Use a wooden pencil with an eraser as a hold-down when crosscutting small parts with a stop block.
- Clear small offcuts before they accumulate, they can vibrate into the back of the blade and kick back. Let the saw come to a complete stop before removing them.
- Never use the rip fence with the miter gauge or crosscut tray at the same time. You can use a stop block attached to the rip fence, if the offcut can freely spin between the blade and fence.

Also see [Common Operations: Crosscutting](#)

Understanding Kickbacks

A kickback occurs when material that is being cut is suddenly driven backwards by the spinning saw blade. This happens when the energy the blade usually puts into cutting is transferred to the workpiece as motion. There are several reasons why this might occur.

Trapped workpiece

When using the rip fence during a typical ripping operation, material is trapped between the right side of the blade and the fence. If the workpiece contacts the back of the blade after the initial cut is made, the blade can pick up the work and propel it backwards. This can occur any time the material being cut is trapped between the spinning blade and something else, usually the fence when ripping, or a stop block when crosscutting. Another situation where the work can unexpectedly contact the back of the blade occurs when tension in the wood is released and the **kerf** closes in as it is being cut. Using a [splitter or riving knife](#) prevents this type of kickback by preventing the work from contacting the back of the blade.

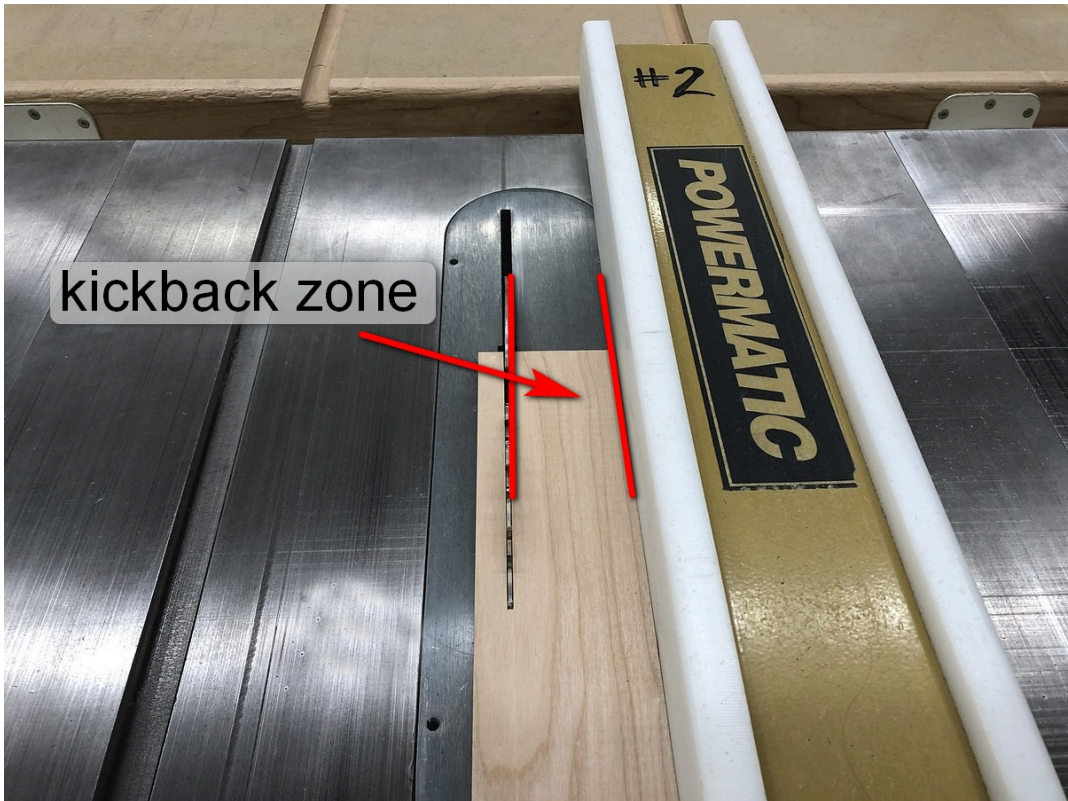

The kickback zone on a table saw when using the rip fence

Riding up on the blade

When material is fed too quickly, it can ride up on the saw blade and lose contact with the table. This creates an unstable workpiece that may unexpectedly catch the blade, especially as it comes back down on to the table. A contributing factor to this type of kickback is sometimes using the incorrect blade for the type of cut, or a dull blade. Using a fine tooth crosscutting blade for ripping is particularly dangerous.

Blade height

Setting the blade too low can be a contributing factor to a kick back. If the saw blade is set low in relation to the work piece, more teeth are engaged in the cut, requiring more power from the saw to complete the cut. The saw is more likely to slow or stall, and can contribute to a kick back. More teeth in the cut requires more force be applied by the operator to push the wood through the saw, which also decreases the safety of the operation.

The direction of force the saw teeth exert on the workpiece also changes in relation to blade height. When the blade is set low, the force is directed in a more forward direction, toward the operator. The operator must work harder to keep the work in contact with the table. When the blade is set high, the direction of force increases in a downward direction, into the table. The cut requires less operator force.

The common belief is that with less blade exposed, the cut is safer as there will be less chance of severing a body part. However, it is important to understand how the forces and power requirements change with different blades heights. Work Safe BC recommends that the bottom of the gullet on the saw blade clear the top of the workpiece by no more than 6mm or ¼ inches.

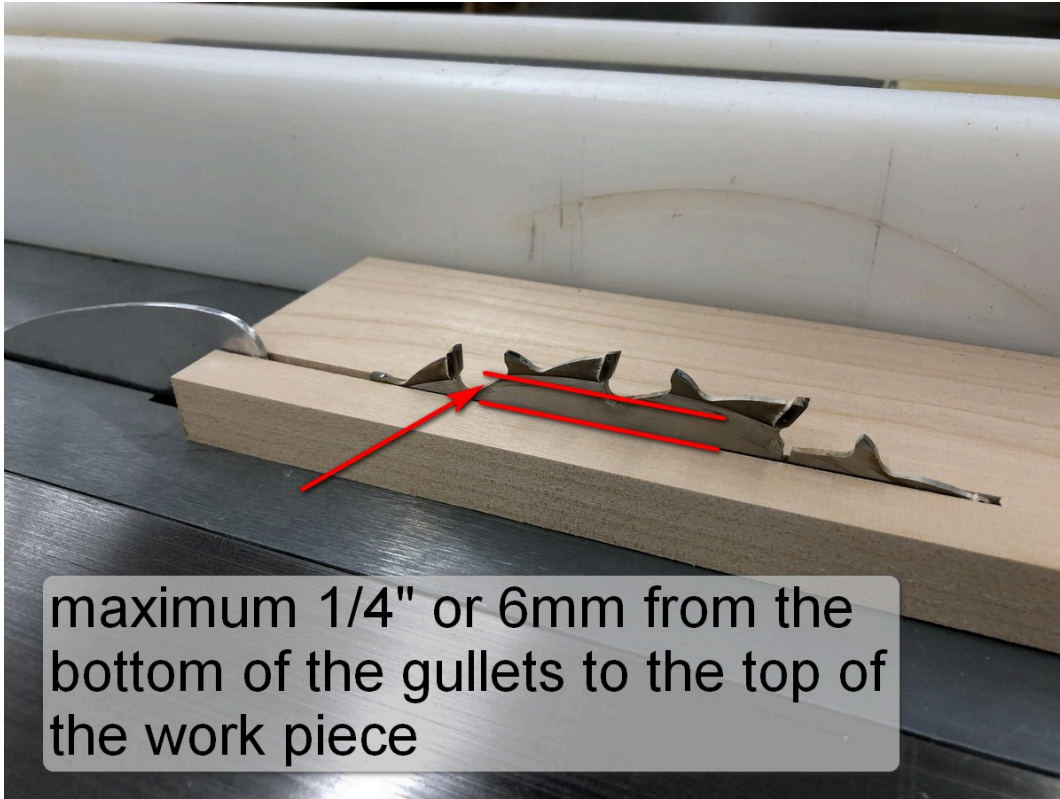

Maximum height of blade above the workpiece

maximum 1/4" or 6mm from the bottom of the gullets to the top of the work piece

Underpowered saw

An underpowered saw can slow down during heavy cuts. As the blade slows, it can catch the workpiece and propel it backwards. If the energy is not put into cutting, it is transferred to other forms, namely motion in the form of a kickback. Thin-kerf saw blades were designed for use on saws with less powerful motors such as contractor saws to compensate for lack of power. When using a thin-kerf blade and a splitter or riving knife, ensure the kerf is large enough to allow the workpiece to pass the splitter without binding. Some splitters are designed to work with typical 1/8" or 3 mm saw blades only.

2. Parts of the Table Saw



One or more interactive elements has been excluded from this version of the text. You can view them online here: <https://pressbooks.bccampus.ca/woodworkingmachinery/?p=91#oembed-1>



Table top

The table on a quality saw is made of cast iron, and is made up of three parts: a main table that is bolted to the saw base, and left and right extension wings that bolt to the main table. Cast iron is desirable as it has a strong dampening effect that mitigates vibration. A properly manufactured cast iron table will also remain flat and stable. Some contractor saws have a cast iron main table and stamped steel extensions on the left and right sides as they are less expensive. The cast iron table must be flat as it forms the reference surface for all cuts made on the saw. The extension wings should be carefully leveled with the main table at the time of assembly, and checked periodically. They provide additional working surface area.

Mitre slot

Mitre slots are machined into the main cast iron table, and are perfectly parallel to the saw blade. They are used to guide jigs such as the mitre gauge. Other manufactured or shop made jigs and fixtures are used in conjunction with the mitre slots to guide work (such as a tenon jig) or increase accuracy and safety (featherboards). There are two styles of mitre slots, plain and 'T' slots. The T style allows the use of hardware that will clamp in place, making it versatile for mounting fixtures or stops. Mitre slots usually measure $\frac{3}{4}$ inches wide by $\frac{3}{8}$ to $\frac{1}{2}$ inches deep.



'T' mitre slot

Mitre gauge

The mitre gauge is used primarily for safe crosscutting, supporting the work at 90° to the blade. Or, the gauge may be set to cut angles from 0° to 45° or greater, depending on the gauge. The gauge will run in either mitre slot, and can be set in either direction relative to the 90° position. An auxiliary fence of plywood or MDF is recommended for both safety and quality of cut. Sandpaper glued to the auxiliary fence can keep the workpiece from sliding during the cut. Mitre gauges are included as a standard accessory with all table saws. Some companies manufacture aftermarket miter gauges that are highly accurate and versatile, especially when used for mitres or complex angle work.

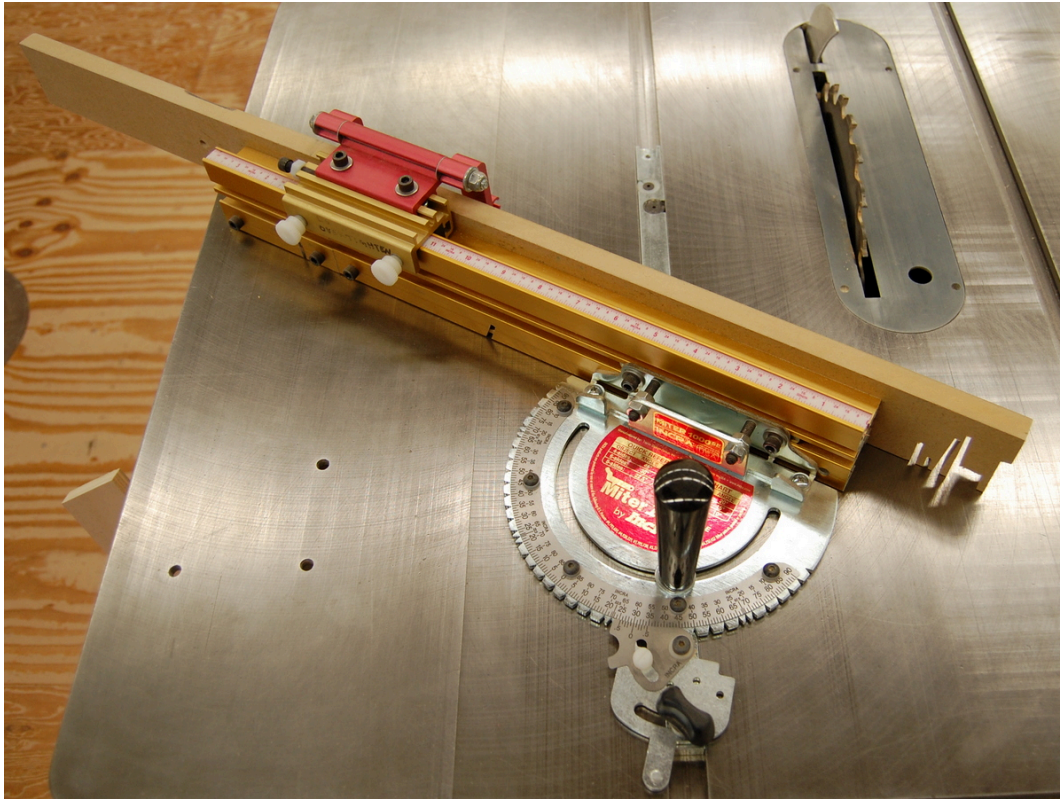

Aftermarket mitre gauge

Throat plate or insert

The throat plate covers the opening in the saw table where the blade projects. It must be used for all cutting operations. The throat plate that comes as standard equipment from the manufacturer is usually made of aluminum, but may also be made of plastic or composite such as phenolic resin. Aluminum is used as it will not damage the carbide teeth of the saw blade if it contacts the blade.

Shop made throat plates are commonly used to provide zero-clearance cutting to the saw blade, or to allow the use of a dado cutter of any width. Having zero-clearance helps prevent small offcuts from getting lodged in the space between the blade and throat plate. They also increase the quality of the cut by preventing tear-out on the bottom of the cut where the blade exits the work.

The throat plate sits on four projections on the saw casting. It must be level with the surrounding table, and is adjustable by means of four Allen screws on the underside of the throat plate. It is very important that the back of the throat plate is not lower than the saw table, as the workpiece will catch the table and be directed into the back side of the blade, posing a kickback hazard. The manufacturers' throat plate has an access hole or finger hole for easy removal, and comes with the blade slot and splitter slot already machined into it. It is never zero-clearance as it is designed to fit the largest blade that the saw can accept (with the exception of dado cutters) with clearance on all sides.



Throat plates, left to right: shop made for dado, shop made, and factory.

Shop made throat plate

With a shop made throat plate, the insert is usually machined out of MDF or quality plywood such as Baltic birch. Composites such as plywood or MDF are preferable to solid wood because they are stable and are not likely to have tension or flaws as is common in solid wood. They are leveled by installing set screws or small wood screws where the plate will contact the casting. The shop made throat plate has the slot for the blade cut into it while positioned on the saw. To do this safely, the rip fence may be locked in place over the right side of the throat plate, and a push stick used to hold the left side while the blade is slowly raised through the insert. Once the blade slot is cut, the access for the splitter or riving knife may be located in line with the blade. Shop made throat plates are often made to allow the use of dado cutters as the opening in factory throat plates is too small to accept them.

Splitter and anti-kickback fingers

A splitter is a thin piece of material (usually steel) that is mounted just behind the saw blade. The purpose of the splitter is to prevent material from contacting the back of the saw blade, a primary reason for a kickback. The splitter, also called a riving knife, is an important safety device that should be used whenever possible. Some operations on the table saw necessitate the removal of the splitter, such as buried cuts and the use of dado blades. Always replace it after performing these cuts.

Always use the splitter when it is possible to do so as it is the most effective safety device for preventing a kickback.

The splitter should be aligned directly behind, and in line with the blade. It should be slightly thinner than the saw blade to allow the stock to move past it without drag. Beware of using splitters with thin kerf saw blades, most are not designed for them and your stock can bind, creating a hazard.



*Splitter on a General
10 inch cabinet saw
(throat plate removed)*

Some splitters come with anti-kickback fingers. These serrated steel plates pivot and move over the top surface as the material is run through the blade. If the stock is moved back out of the saw, it jams in the serrations and is prevented from kicking back. The height of the anti-kickback fingers must be set properly for them to be effective.

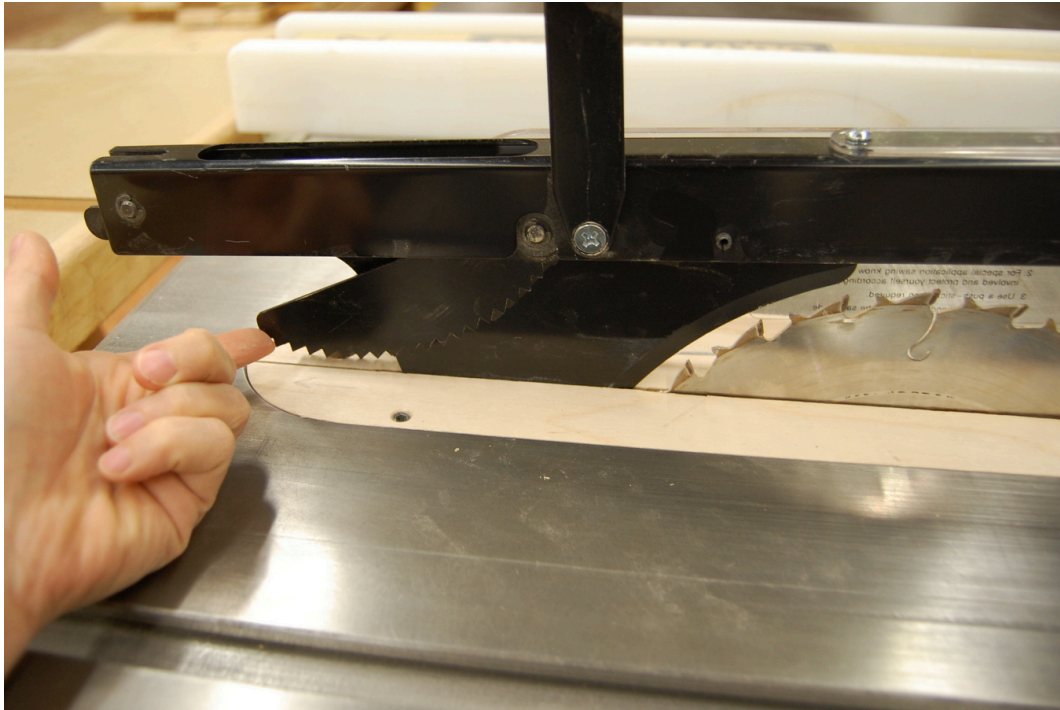

Anti kickback fingers

Blade guards

The blade guard is designed to protect the operator from accidental contact with the blade. They also direct sawdust and small particulate away from the operators face. There are two types of blade guards. The first type attaches to the saw trunnion (the movable part of the saw below the main table). This blade guard assembly is made up of the guard, splitter or riving knife, and sometimes anti-kickback fingers. This type of guard is typically supplied with the machine.



Blade guard attached to splitter on a sliding table saw

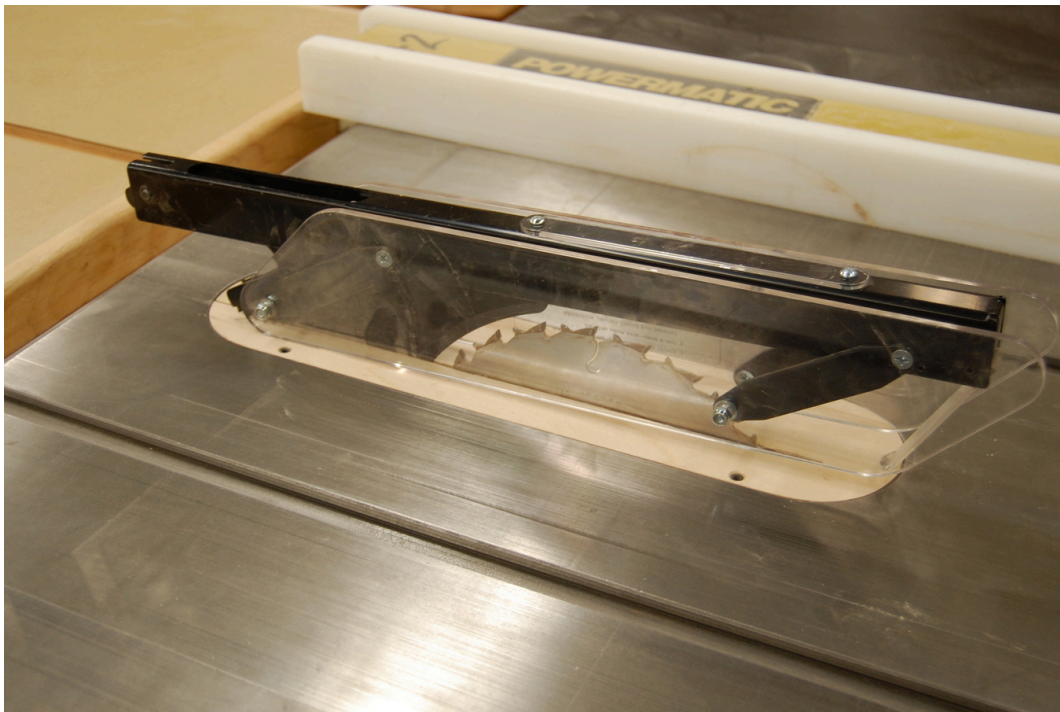

Guard assembly with splitter and anti-kickback fingers on a cabinet saw

The second type of guard is an over-arm guard that usually attaches to the extension table. These guards can be purchased as an aftermarket item if the original guard is missing. They are often easy to adjust for different

heights of cut, and may have dust collection. They do not have splitters or anti-kickback fingers, these should be installed in addition to the over-arm guard.

WorkSafe BC stipulates that guards may be removed for a specific operation that prevents their use, or if the guard creates a hazard as long as appropriate measures such as push sticks and feather boards are in place. The guard must be replaced after the operation is complete. Refer to [worksafe reg. 12.59](#)).

Rip fence

Rip fences are straight guiding fixtures which are secured at a measured distance from the saw blade. This kind of fence works by remaining parallel to the saw blade no matter what distance it is adjusted to, ensuring that two or more boards passed between the blade and the set fence will measure the same size.

Most new fence designs come with some type of locking mechanism that ensures that once the fence and blade are adjusted into parallel, the setting will remain consistent. The Biesemeyer "T-Square" and SawStop T Glide are common fences found on cabinet table saws. Most new table saws come with fences that will remain parallel to the blade. It is worth noting that while the fence can be set exactly parallel to the blade, having one or two thousandths of an inch difference between the leading and back edge of the blade can be desirable. This eliminates the teeth that are exiting the table from contacting the wood that has already been cut, resulting in a cleaner edge and possibly reducing the potential for kickback.



*Biesemeyer
"T-Square" fence
installed on a 10 inch
cabinet saw*

See also [Set-up and Maintenance: Adjusting the rip fence \(T-style\) to the blade.](#)

European Rip Fences

An alternative style of fence is found on saws that originate in Europe. Most sliding panel saws also use this design, which provides for the fence to be locked in different locations along its length. This allows the fence to be positioned before the blade and safely used as a moveable stop as the offcut is clear of the fence as it cuts.

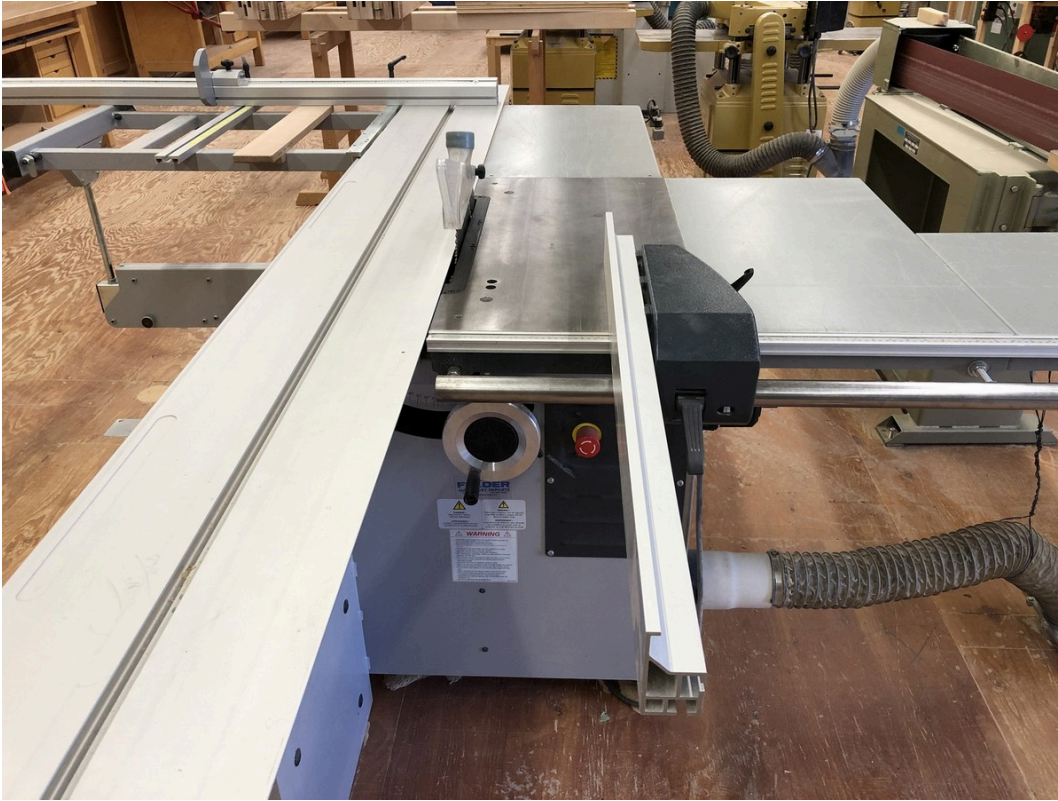

Rip fence positioned for use as a moveable stop for crosscutting.

The rip fence has a high and low position which is achieved by the use of an aluminum extrusion that has two positions. The high position is used for tall or wide work, the low position allows for narrow work while leaving clearance for the saw guard to clear the fence.

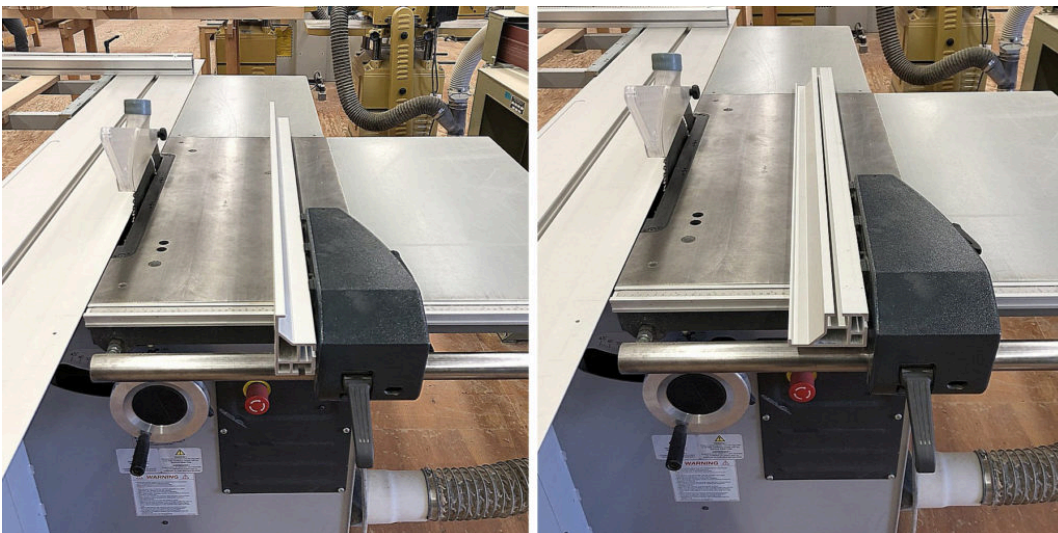

High and low positions on a European fence

Rip fence locking handle

An eccentric cam is part of the rip fence locking device, and provides ample mechanical locking force with little pressure.

Front rail for rip fence

The front rail on a 'T' style rip fence provides a bearing surface for the locking mechanism of the fence.

Rear rail for rip fence

The rear rail on a 'T' style rip fence is not needed for the operation of the fence, but provides structure for the right table extension.

Right table extension

This table provides support for larger work pieces such as sheet goods. It is a convenient place to stack parts for processing through the saw. It should be kept clean and clear of clutter. It also supports the rip fence rails on cabinet saws.

Auxiliary outfeed extension table

Almost every cabinet saw has this shop made accessory table. It prevents the work from falling off the back of the saw as it is cut. It should have slots machined in it to allow for accessories that use the mitre slots in the table top.

Magnetic control switch

Magnetic controllers are standard on all industrial saws. Magnetic switches are safer because they physically break contact when the power supply is interrupted, and won't turn back on when the power resumes.

Power disconnect

When changing the blade, doing set-up that brings your body close to the blade, or performing maintenance, you must disconnect the machine from the power source. This can be done by unplugging the saw, or in the case of a hard-wired machine, by using the appropriate lock out procedure at the breaker panel.

Ensure you understand how to lock out power to any machine you are using before performing any adjustments or maintenance.

Height adjusting handwheel

Turning the hand wheel raises and lowers the saw blade to adjust the depth of cut, it is always located on the front of the saw. Most hand wheels have a lock. It is not necessary to lock the hand wheel for simple through cuts, it is advisable to lock it for any operation that requires the blade height to be precise. To maintain an accurate depth of cut, start with the blade low and increase up to the desired setting. This will ensure vibration from the machine does not alter the height due to backlash in the screw mechanism.

Tilt handwheel

The tilt handwheel engages the trunnion assembly which tilts the blade relative to the table. The handwheel is located on the left or right side of the cabinet directly underneath the table. A bevel scale is located on the front of the machine and indicates the degree of tilt. There are positive 90° and 45° stops for these two common positions that can be calibrated for accuracy, refer to the owner's manual for instructions on how to adjust them.

Table saws that tilt the blade toward the rip fence are called right tilt saws; the handwheel is located on the left side. Saws that tilt the blade away from the rip fence are called left tilt saws; the handwheel is located on the right hand side.

Left versus Right Tilt Saws

Most new cabinet saw models are left tilt. It is believed left tilt saws are safer when ripping as the workpiece is not trapped under the blade and between the fence. This has a greater risk of kickback if the workpiece rises up relative to the blade. However, bevel rip cuts can safely be performed on a right tilt saw by moving the rip fence to the left side of the blade.



Ripping bevels on a right tilt saw

It is important to note with left-tilt table saws that when the saw blade is installed, it references the left side of the saw blade against the arbor flange. Because the rip fence is on the right side of the blade, changing between thin kerf ($3/32$ inches) and standard saw blades ($1/8$ inches) will throw off the calibration of the rip fence depending on what thickness of blade was installed in the saw when the fence was calibrated. This is a major disadvantage of left tilt saws, and something to be aware of when using the rip fence scale.

Tilt/bevel scale

The scale for the blade tilt is located on the front of the saw. It is not highly accurate for setting of angles between 90° and 45° . Use a reliable layout tool such as a drafting set square, sliding 'T' bevel, or digital inclinometer. The trunnion assembly references positive stops at 90° and 45° ; these may be need to be cleaned of debris and calibrated periodically.

Arbor assembly

The arbor assembly is comprised of the shaft, bearings, flange, arbor washer and nut. This assembly is connected to the drive system, and is where the saw blade mounts. The end of the shaft is threaded for the arbor nut that secures the blade in place. The most common arbor diameter for a 10 inch cabinet saw is $5/8$ inches. Industrial panel saws have a larger arbor, commonly 30mm.

The arbor shaft usually has a left-hand thread, which is opposite to the blade's rotation. This ensures that the nut does not loosen with use.

Trunnion assembly

The trunnion assembly is what allows the saw to tilt. The trunnions are the part that ride in semicircular trunnion brackets, these are usually visible from the throat opening looking toward the back of the saw. The entire trunnion assembly may be bolted to the saw cabinet or the underside of the cast iron table. If the saw blade is out of alignment with the miter slots, the trunnion assembly must be loosened from the mounts and adjusted.

Drive belt

Most industrial table saws use a pulley and drive belt to transfer power to the arbor. This allows the arbor assembly to be as close as possible to the underside of the table without the motor interfering, which has the advantage of allowing a greater depth of cut. The belts wear and need to be replaced periodically. Some table saws, especially smaller portable models may use a direct drive system where the motor is connected directly to the arbor.

Parts specific to the panel table saw

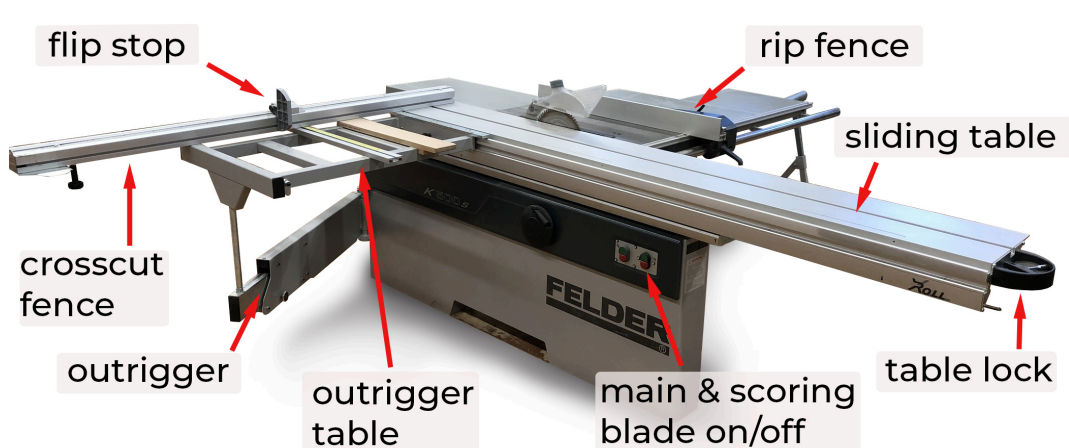

Parts of the panel saw

Sliding table top

The sliding table varies in length depending on the saw. It is machined from aluminum, and has a 'T' mitre slot along its length for receiving hold-downs and jigs. The table slides on a chassis (attached to the main body of the saw) on roller bearings. A lock on the sliding table allows it to remain motionless while sheet goods are loaded on and positioned against the fence. It is common for the sliding table to be set about 10 thousandth of an inch higher than the main table to reduce friction and drag on the part being cut.

Crosscut fence and outtrigger table

An aluminum crosscut fence is attached to the sliding table. The fence has a measuring tape similar to the

rip fence for accurate measurements with the flip stops. Some crosscut fences have a telescoping feature that supports the work and the stop, allowing long lengths to be cut. The fence holds one or two flip stops, which make it possible to square an end on multiple parts and cut them to length. They move up out of the way of the crosscut fence when not in use.

Panel saws have an outrigger table that attaches to the sliding table and is supported by the outrigger. This table extends under the crosscut fence to support large work pieces, while the outrigger prevents the table from sagging. On most saws, the table can be positioned at any point along the length of the sliding table. When crosscutting smaller pieces, it is sometimes desirable to have the fence/outrigger table assembly near the midpoint of the sliding table so less of it is projecting out the back of the saw.

The crosscut fence uses positive stops to keep it at 90° to the blade. These may need to be calibrated periodically. The crosscut fence may also be positioned at an angle. On most saws, there is a pivot point where the fence bolts nearest the saw blade. To angle the fence, loosen the lock bolts, pivot the fence and re-tighten the locking mechanism to the outrigger table. While the table may have an angle indicator, it is best to use a more reliable method of setting the fence. Always check that the table is cutting square when you return it to 90° by using a reliable square and making a test cut.

The sliding panel saw is unique from the table saw in that the crosscut fence is usually positioned on the far side of the material being cut. The stock must be held tightly against the fence as the force of the blade is acting to push it forward. The fence is positioned this way so that large sheets can be slid onto the table without having to clear the crosscut fence. On a sliding table saw, using the outrigger table and crosscut fence is the ideal position for the workpiece and the place where most of the cutting happens.

Scoring blade

As panel saws are used to cut veneered and melamine panels, they have a scoring blade unit that serves to reduce tear-out and chipping on these delicate materials. The scoring blade is located directly in front of the main blade. It is used for cutting sheet goods only, and can be lowered below the table when not in use.

The scoring blade is set slightly above the main table, and rotates in a direction opposite the main saw blade. Its width must be carefully calibrated to the kerf of the saw blade; if it is too narrow it will not prevent chipping, if it is too wide the panel will be overcut. To achieve a perfect width, scoring blades are manufactured to be adjustable. They are comprised of two outside blades and some means to space them apart, either by thin metal shims (similar to dado shims) or by a dial mechanism.

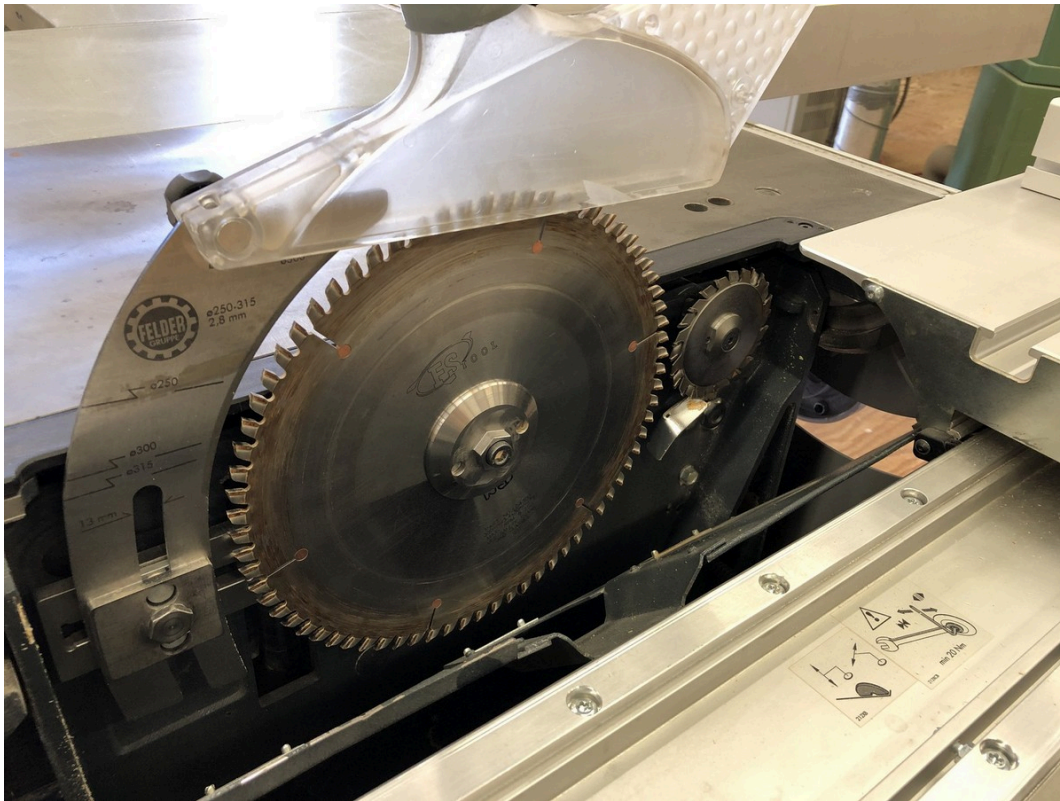

Main blade and scoring blade in a panel saw

In addition to an adjustment for height, scoring blades have a provision for lateral adjustment. This adjustment is used to ensure they are cutting centered in the kerf of the main blade. Both lateral and height adjustments are made from an access point in the top of the main table. Whenever the blades are sharpened or are changed, both the kerf width and lateral alignment of the scoring unit must be checked and recalibrated.

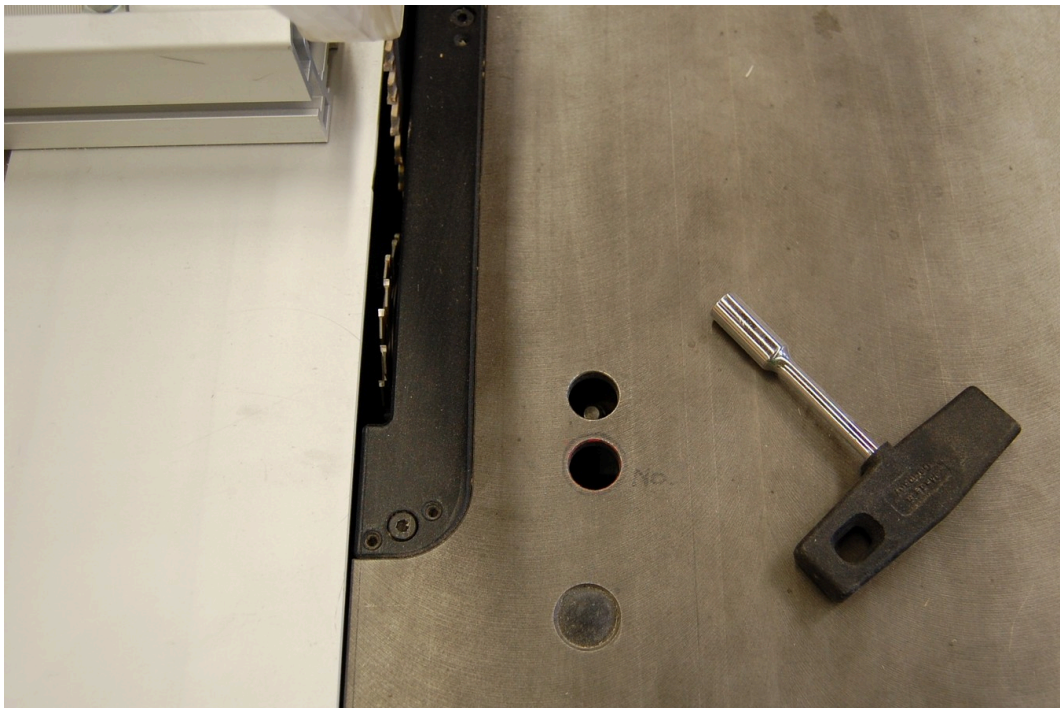

Scoring blade adjustment access and wrench

To check and recalibrate:

- Turn on the saw, including the scoring blade. Run a scrap of veneered plywood into the saw until the main saw begins cutting.
- While holding the workpiece securely on the table, shut off the saw and wait until it comes to a complete stop.
- Remove and inspect the piece. The kerfs of both blades should be perfectly aligned and there should be no tear-out or overcutting.
- If the scoring cut is cutting past the kerf of the main blade on one side, use the lateral adjustment to move it in the desired direction. It is accessed through the top of the saw table. Re-check by making another test cut.
- If the scoring cut appears centered in the main blade kerf, but is cutting past it on both sides, the scoring blade kerf is too wide. Depending on the type of scoring blade, adjust the width of cut by removing shims or adjusting the dial and re-check.
- If it is centered but undercutting, it is too narrow. Adjust the width of cut and re-check.

3. Tooling and Blade Selection



One or more interactive elements has been excluded from this version of the text. You can view them online here: <https://pressbooks.bccampus.ca/woodworkingmachinery/?p=95#oembed-1>

Almost exclusively, modern table saw blades have teeth made of tungsten carbide, a chemical compound containing equal parts tungsten and carbon. It is approximately twice as stiff and double the density as steel. Carbide can cut all wood products, dense composite materials such as Corian™, and non-ferrous metals such as brass, copper and aluminum. Carbide is extremely hard, therefore it maintains sharpness over a long period of use in the woodworking shop. The flip side of this extreme hardness is that it is brittle.

- Use care when installing the saw blade not to touch the teeth to the surrounding saw casting.
- Do not set saw blades down directly on the cast iron saw table.
- Do not place carbide cutters of any kind in contact with each other- they can dull and chip easily.
- Use a dedicated saw blade holder, or use a protective layer between the blades. A simple square of cardboard can work.

Carbide is too hard to sharpen without diamond tooling, and modern saw blades are highly accurate cutting tools. When carbide blades require sharpening, they are sent out to a sharpening service. Most companies use CNC (computer numerically controlled) technology to sharpen the blades.

Selecting the correct saw blade is critical to safe use of the table saw as well as obtaining a quality cut. Table saw blades fall broadly into five categories: crosscut, triple chip, rip, combination blades (simple & planer style), dado cutters and moulding heads. Knowing the components that make up a blade and understanding the geometry will allow you to select the correct blade for the cutting operation.

Saw Blade Components

While the geometry of circular saw blades varies, they are comprised of the same basic components.

Components of a circular saw blade

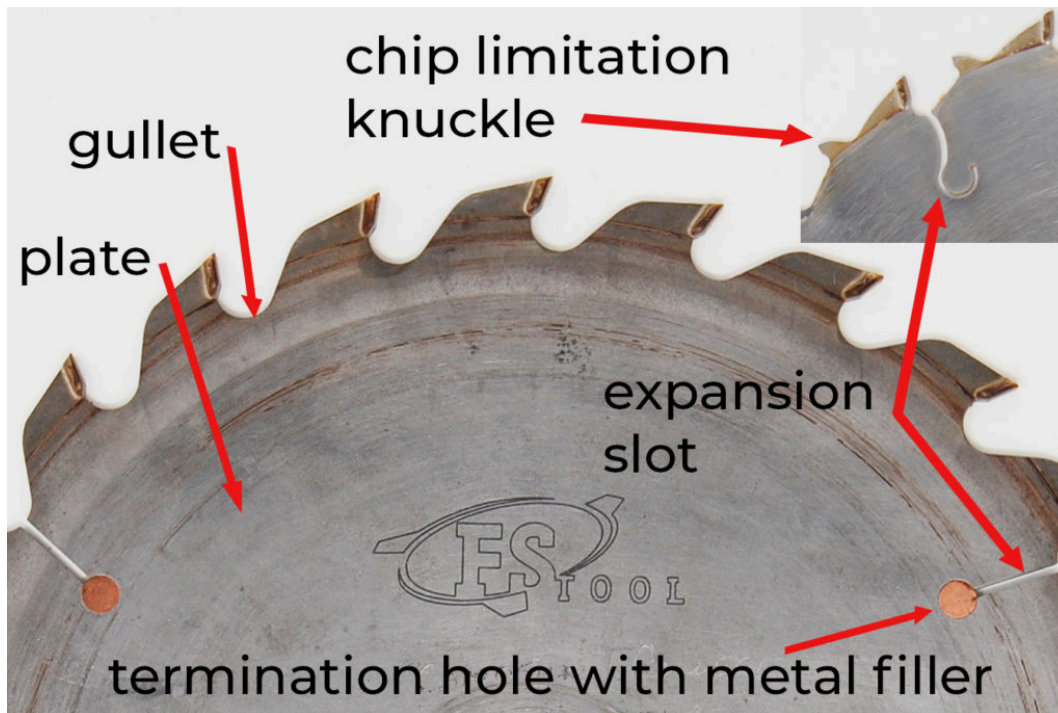

Plate

The plate comprises the main body of the blade. It may be stamped or laser cut. Laser cut blades are more expensive, the quality ones are very flat and stable and run quieter than stamped blades. In both types of blades, the plate must be flat and true to produce accurate cuts and prevent excessive noise. All plate bodies are thinner than the teeth to provide clearance to the work piece, some also have a friction reducing coating such as Teflon™. The hole in the blade that allows it to mount on the arbor shaft is called the bore. Common arbor sizes are 1/2", 5/8", 3/4", 7/8", 1", 20 mm, 30 mm, and 32 mm. A 5/8" arbor is common on portable, contractor and cabinet table saws sold in Canada.

Expansion slot, termination hole, metal filler

Saw blades heat up in use due to friction, heat causes the plate to expand. To prevent the plate from warping, most blades have expansion slots to allow for expansion without impacting the performance of the blade. The termination hole at the bottom of the slot reduces stress on the surrounding metal. In some blades, the termination hole is filled in with a soft metal such as copper which helps reduce noise.

Gullet

The gullet is the space between the teeth of the blade, it has a smooth rounded shape. The purpose of the gullet is to give the chips a place to go immediately after they have been generated by cutting action. Rip blades have deep gullets which help clear the longer, stringy chips that are created when cutting with the grain in solid wood. Deeper gullets clear chips more effectively.

Chip limitation knuckle

Blades designed for ripping solid wood have fewer teeth and deep gullets. This leaves a lot of space between the teeth. With this blade geometry, it is possible to feed the stock very quickly into the saw blade, which can create a kickback hazard. To help prevent this, the plate can be extended behind the tooth to prevent feeding too aggressively into the next tooth. This is known as a chip limitation knuckle.

Braze

Individual carbide teeth are attached to the plate with a process called brazing. If you look closely, you will see a thin gold coloured zone between the plate and the tooth, this is the braze. Better saw blades achieve a stronger connection between the teeth and the plate by shaping the plate to accept the tooth on two edges. If a carbide tooth is damaged on a quality saw blade, it can be replaced by a company that sharpens saw blades.

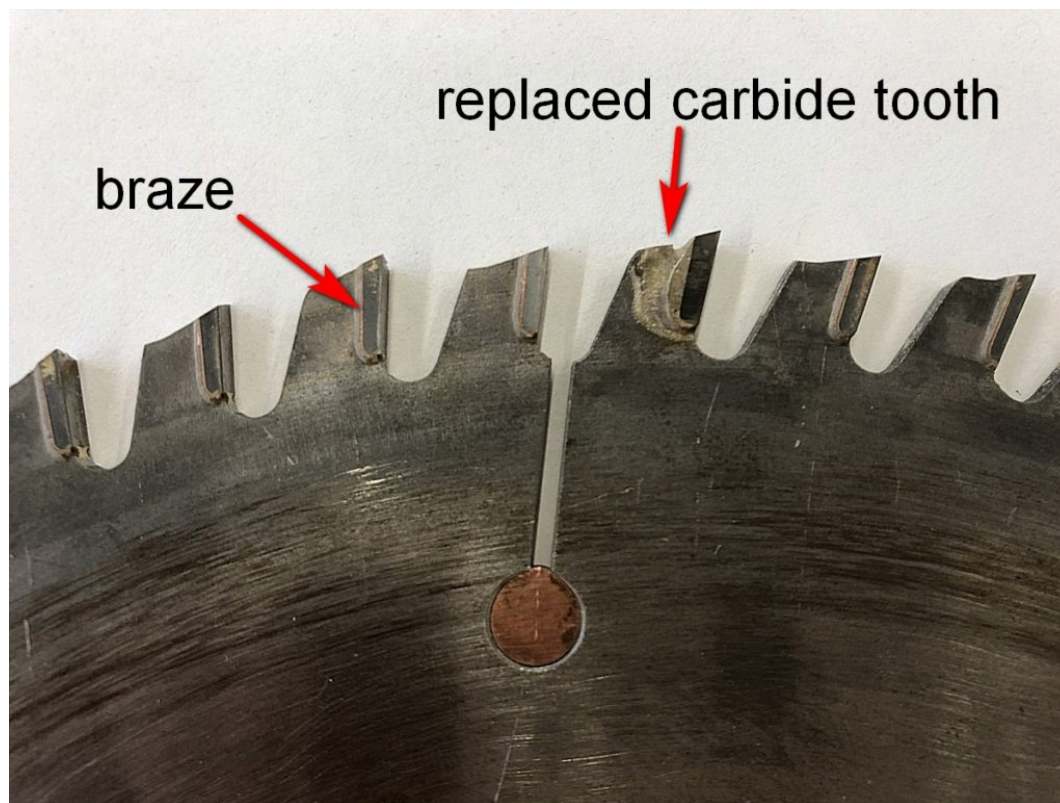

Carbide brazing

Saw Blade Geometry

The differences between the saw blades have to do with blade geometry. It is important to understand the following terms. These universal terms relate to other types of cutting tools, including hand saws and router bits.

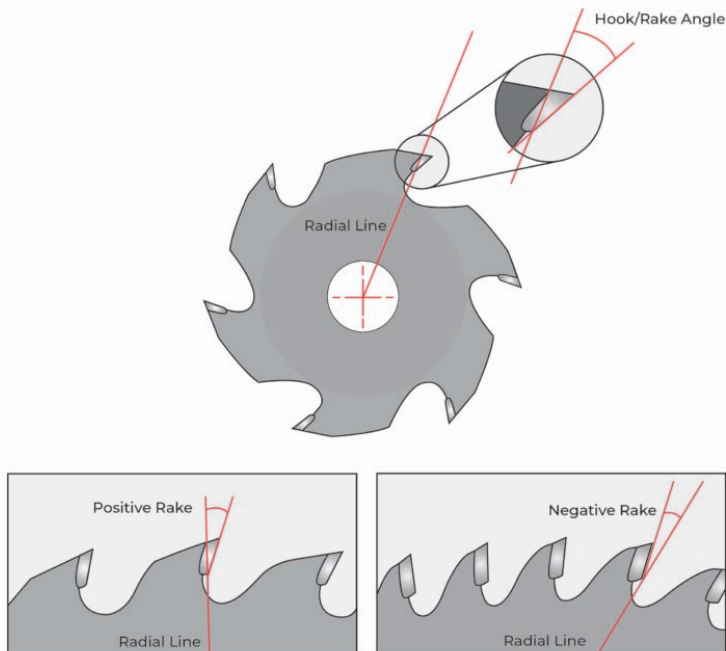

Radial line

Imagine a line drawn from the center of the saw blade to the outer edge. This is the radial line that other saw geometry relates to.

Hook angle or rake

The angle of the tooth relative to the radial line. Hook angle is a primary determinant of how aggressive a saw will cut. Rake angles range from -6° to 20° .

If the face of the tooth is in line with the radial line, it is said to have a neutral rake.

If the face of the tooth leans forward from the radial line, it has a positive rake or hook. All rip blades and most crosscut blades have a positive hook. The steeper the hook, the more aggressive the cut will be. Blades for ripping solid wood commonly have angles of 20° . Blades for crosscutting range widely depending on the application (solid wood, plywood, MDF) from about 5° to 15° .

If the face of the tooth leans back from the radial line, it has a negative hook. Negative hook saw blades are used on sliding mitre saws and radial arm saws. This geometry does not have the tendency to grab and potentially self-feed into the work. Negative hook geometry is used for cutting very hard or abrasive material. Using a negative hook blade lessens the potential impact on the carbide as the lower portion of the tooth contacts first where there is more material to absorb the force.

Point or top bevel angle

The angle the tooth is ground across the top. If you pick up the saw blade and look at it as if it were cutting, the bevel angle is the profile on the top of each tooth. The bevel angle is designed to sever the fibres of the material. In the case of a ripping blade, the tooth must sever at 90° to the direction of cut, therefore they have a flat-top or chisel grind. The top bevel angle would be 0°. When crosscutting, the teeth are severing fibres in line with the direction of cut, so a top bevel angle alternates from tooth to tooth. Crosscut blades have bevel angles from about 10°-20°. Specialized blades for cutting melamine have angles from 30°-40°.

Face angle

The angle of the face of the tooth as you are looking down on the blade as if it were in the table. Blades for cutting very brittle materials such as melamine or materials prone to tear-out such as veneered plywood may be ground across the face to achieve a cleaner cut.

Top bevel angle and face angle

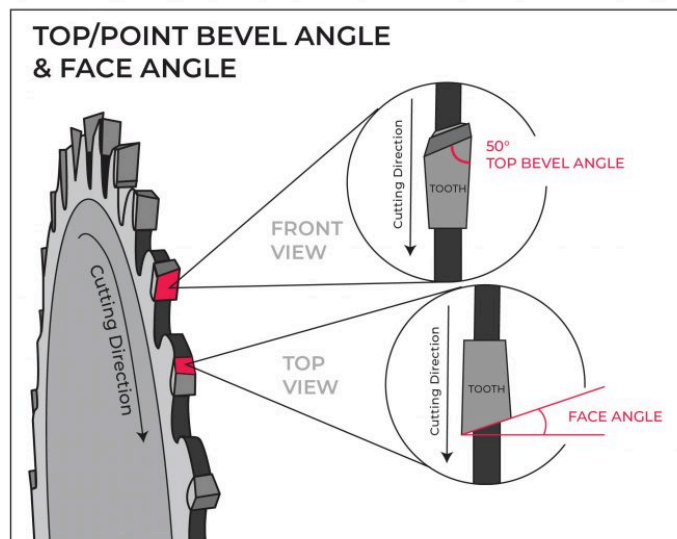

Top and side clearance

Once the tooth has made contact and cut the material, the tooth should not continue to contact the work. This allows the tooth to cut efficiently and reduces heat due to friction. Clearance angles on the side and top of the blade are necessary for efficient cutting action.

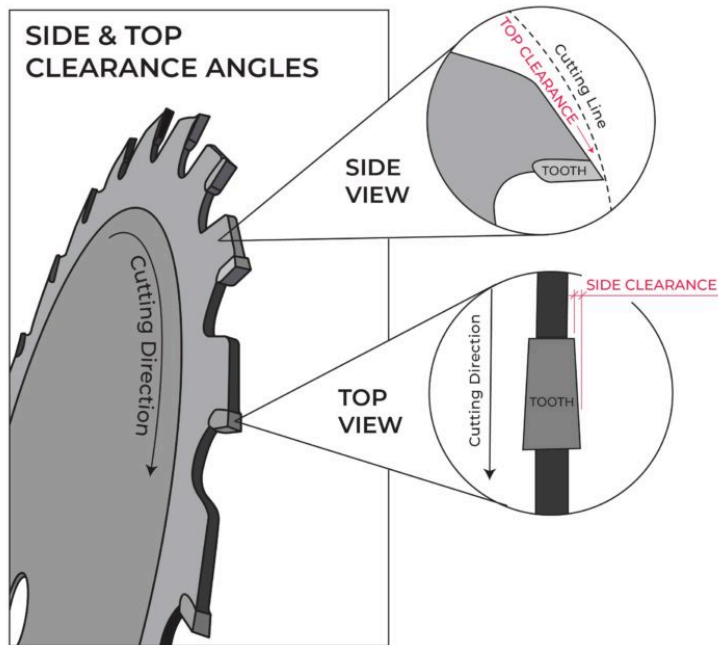

Number of teeth

Blades with more teeth cut slower, but leave a cleaner cut. Blades with fewer teeth cut faster but tend to leave a rougher surface. Blades designed for ripping solid wood have fewer teeth as more space is needed between them to clear the longer, stringy chips that are generated. Blades for crosscutting have many teeth to create a smooth, clean cut across the grain.

Common Blade Grinds and Types

Circular saw blades for woodworking can be classified according to use. There are four general blade types that are common in the woodworking shop including crosscut, triple chip, rip, and combination.

The aspects of blade geometry are combined in different configurations for optimal, safe cutting in a variety of materials. The specific tooth pattern in a circular saw blade is known as a grind. Efficient, accurate and safe cutting requires the use of the right blade. The common grinds and their applications are explained below.

Crosscut blades

Crosscut blades are designed for crosscuts in solid wood and cutting plywood in all directions. They use an

alternating top bevel (ATB) grind and have a high number of teeth per blade. A typical 10" crosscut blade has 60-80 teeth, with 80 tooth blades producing a finer cut.

They should never be used for rip cuts as the large number of teeth and the rake angle require a high amount of force to feed the stock, increasing the potential for a kick back. They can overheat and burn the wood if used for ripping solid stock.



Crosscut saw blade

ATB Alternating top bevel with a positive rake



- This tooth pattern has an alternating sloped top grind that can come in varying degrees of angle. The 15 degree is typical for general purpose crosscutting of wood and plywood. The positive rake indicates that the tooth "leans forward" which helps the blade bite into the material without a large amount of feed pressure. Typical number of teeth on a 10" saw blade, 60-80, up to 120.

Hi-ATB High angle alternating top bevel



- These come in a 30 to 40 degree top bevel with a negative rake. This version is especially suited to extra clean top and bottom cutting in chip and tear-out prone materials such as melamine or thin veneered plywood. This blade is also very effective in mitre or chop saw applications for clean mitre cutting of wood mouldings. Typically 80 teeth on a 10" saw blade, up to 120.

Triple chip blades

These blades are designed for cutting hard and abrasive materials such as melamine, composite materials, and non-ferrous metals. Triple chip saw blades look similar to crosscut blades, but a closer look reveals an important difference in the tooth geometry. The teeth are not angled across the top, and the corners of alternating teeth are beveled. This helps protect the brittle carbide teeth from being damaged or prematurely worn by hard materials. While this grind will stand up well to cutting materials such as melamine, it does not produce as clean a cut on the back side as an ATB or Hi-ATB grind, and should be used with a scoring blade.

Only triple chip blades should be used for cutting non-ferrous metals such as copper, aluminum and brass.

TCG Triple chip grind

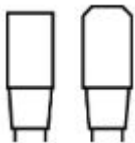

- This pattern looks like the rooftop of a barn when you look at it face on. This tooth has a "ploughing" action that is especially effective when cutting man-made materials like particle board, melamine (best used along with a scoring blade) and when coupled with a negative rake, plastics, solid surface and aluminum. Typically, 80 teeth on a 10" saw blade, up to 120.

Ripping blades

Ripping requires severing the long fibres of solid wood at 90° to the kerf. To accomplish this, the teeth of these blades are shaped straight across the top to cut the fibres ahead of the tooth removing the waste. This type of flat-top tooth is also known as a raker tooth. Rip blades have fewer teeth, with large gullets to clear the long, stringy fibres that are generated. They can leave somewhat rough surface, particularly if used for crosscutting.

While ripping blades commonly have this flat top grind, some blades may also have the corners of every 3-4 teeth beveled, as in the triple chip grind. These teeth also have a slightly greater cutting depth, allowing these teeth to remove the bulk of the material while the flat top grind squares up the kerf. They tend to leave a cleaner

edge that true FTG blades. They are not desirable if the blade is used for buried cuts such as grooves, or for joinery as they do not leave a flat bottom kerf.



Rip saw blade

FTG Flat top grind

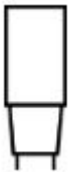

- The teeth on these saw blades are square top. The most common place you will see these teeth is for ripping (with the grain) solid wood. Usually has a fairly aggressive positive rake and lots of space between each tooth, these blades will saw through solid lumber quickly. With a fast cutting action, a fairly rough cut is the result. Typically have 24 teeth on a 10" saw blade.

Combination blades

If a single saw is used for both crosscutting and ripping, it can be tedious and time consuming to change

the blade for every cut. Combination blades will perform both rip and crosscut operations in solid wood and plywood. However, they are a compromise and usually do not perform as well as a dedicated crosscut or rip.

Simple combination blades have teeth of the same grind evenly spaced. They produce a decent rip or crosscut and are suitable for general purpose work.

Planer style combination blades group four ATB crosscutting teeth with one raker (ripping) tooth. A large gullet after the raker tooth provides space to remove the long fibres created when ripping. A quality planer combination blade can produce a good cut if kept sharp and clean.

If ripping dense wood or if the material is thick, it is better to change the saw blade and use a dedicated ripping blade as both the performance and safety is reduced.



Planer style combination saw blade

COM Combination

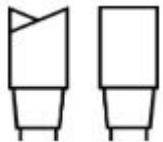

- The utilitarian of wood cutting blades, this blade combines the ATB and FTG patterns into one saw blade. The pattern typically consists of 4 ATB teeth followed by 1 FTG and then a large gap before the next set of teeth. Typically these have from 40-50 teeth on a 10" saw blade.

Thin kerf blades

On most cabinet saws, the standard blade has a kerf of 1/8" or 0.125". Thin kerf blades have a kerf of 3/32" or 0.094". A thin kerf blade requires less power to execute the cut, and are a good choice for smaller table saws, particularly contractor and portable table saws. They also can be used to conserve material as the kerf is smaller.

It is important to note that most splitters are designed for standard 1/8" saw blades. If a thin kerf blade is used the material can be impeded by the splitter, creating a hazard. Thin kerf blades, with a thinner saw plate have a tendency to vibrate, reducing the quality of the cut. They may also overheat more easily. On a left-tilting table saw, changing between a standard and thin kerf blade will necessitate changing the calibration of the rip fence.

Never use thin kerf blades with splitters designed for standard 1/8" saw blades.

Dado Cutters

A dado set is comprised of separate cutters that are used in combination to achieve cuts of varying widths. The set is comprised of two saw blades that are placed on the outside of the cut, and internal cutters called chippers that clear the waste between the blades.

They are commonly used to cut dadoes, grooves and rabbets, as well as other joinery such as finger joints and open mortises.



8" x 46 tooth dado set with assorted shims.

Use an abundance of caution when using dado blades. As the volume of cut increases, the potential for accidents increase if the stock is fed too quickly. There is also more saw blade exposed.

Components

The two outer saw blades in a dado set are handed, and must be used on the correct side of the cut. Each of these blades has a top bevel in one direction only to aid in severing fibres when used across the grain. Additionally, they are made with a slight relief on the inside of the plate that contacts the chippers to ensure the teeth on the different cutters do not contact one another. They may include a flat top raker tooth as well to aid in chip clearance during rip cuts in solid wood. The chippers have only two teeth with a flat-top raker grind. These should never be used on their own.

Dado blades can cut with or across the grain in solid stock and plywood and composites. Typically, a 10" table saw will be used with an 8" dado set. They can have from 24 to 46 teeth (per blade), with a 46 tooth set being used for fine crosscutting in hardwoods and clean cutting in materials such as melamine. 24 tooth sets are more common, and are used for general purpose work.

Installation on the saw

When installing the dado set on the saw, the chippers should be staggered radially to maintain balance of the dado stack. Care should be taken to position the teeth so they are not touching each other. This prevents damage to the brittle carbide, prevents loosening during use, and ensures the dado will cut the width it was designed to.

Set-up to obtain the desired width of cut

The cutters in a dado set are manufactured to cut in precise increments. The sizing of most commonly available dado sets is in imperial measurement. The smallest dado that can be made with the set is 1/4" using the two outside sawblades only. Sets usually have from four to six chippers, depending on the manufacturer. The chippers are individually sized to cut 1/16", 1/8", and 1/4" increments. Combining these allows cuts from 1/4" to 13/16" in 1/16" increments with most sets.

Using shims

In order to achieve precise widths that differ from these 1/16" increments, a set of shims may be used. These shims are made from thin plastic or metal, and are spaced between the cutters. When using more than a few thin shims or thicker shims, it is best practice to spread them between multiple cutters. This ensures there are no areas left uncut by spacing the chippers farther apart.

The thickness of the shims is usually indicated in decimal inches. By converting the thickness of the saw blades and chippers to decimal inches, precise widths of cut can be obtained. For example, each outer blade

will cut $1/8$ ", or 0.125 ". A dado set with the $1/16$ " chipper installed will cut 0.125 " + 0.125 " (two outside blades) + 0.0625 " (chipper) for a total of 0.3125 ", or $5/16$ ". If a dado of 0.3525 " was required, dado shims equaling 0.04 " would need to be added. Measuring using Vernier or digital calipers when setting up dado blades can save time and guesswork. The part that will be fit into the dado or groove is measured with the calipers in decimal inches, then the dado stack can be configured to the correct measurement using shims. Always make a test cut to confirm.

4. Common Operations



One or more interactive elements has been excluded from this version of the text. You can view them online here: <https://pressbooks.bccampus.ca/woodworkingmachinery/?p=99#oembed-1>

The table saw is the tool of choice for many basic ripping and crosscutting operations. Often, **jigs** and **fixtures** are used to increase safety, accuracy, and speed. A number of common table saw set-ups for both ripping and crosscutting operations described below.

Ripping operations

When performing ripping operations, the workpiece should always be positioned between the rip fence and the blade. Only in rare situations is the component being cut positioned to the left of the saw blade. Always positioning the work between the blade and the fence ensures all the pieces being cut will be the exact same width and have parallel edges. If the piece being ripped is narrow, it is acceptable to run a wooden push stick right through the blade with the work. The part being ripped should have one flat face and one straight edge. Follow all [guidelines](#) for safe ripping.

Any stock being ripped should have one flat face that contacts the saw table, and one straight edge that contacts the rip fence.

Ripping bevels (blade tilt operations)

Performing rip cuts with the blade tilted is a common operation. If the workpiece rises off the table, an increased hazard of kickback is present as the piece is constrained between the angled blade, table, and rip fence. Left-tilt saws are thought to be safer when performing this operation as the blade tilts away from the fence and therefore the work can lift slightly off the table with less potential for kickback. When ripping bevels on a right-tilt saw, move the rip fence to the left of the saw blade. It may feel awkward at first, but it is safer.



Bevel rip on a right tilt table saw. The blade is tilted at 45 degrees

With either a left or right tilt saw, plan the cutting sequence carefully. Be aware that a sharp feather edge placed against the bottom of the rip fence can get jammed. Use a zero-clearance sub table to lift the work up if the saw has any clearance between the fence and the table. Also consider the size and orientation of the workpiece and offcut once the cut is completed. A 45° rip cut can leave little material supported by the table and it can have a tendency to fall into the blade. In some cases, you may need to leave extra width on the stock, cut the bevel, and then cut the piece to final width.

Tilted saw blades when both ripping and crosscutting can have a tendency to 'pull' the stock because of the direction of force acting on the work. For accurate cuts, it can be advantageous to cut the piece slightly oversized adding 1-2 mm, then trim to final size.

Use an abundance of caution when ripping bevels. If the stock lifts off the table, it is constrained by the tilted blade and the potential for kickback is high.

Using featherboards for rip cuts

Featherboards are fixtures that help keep the stock being fed tight to the fence, and also help prevent kickback. They are used on numerous machines for both safety and accuracy. The flexible fingers keep tension against the material as well as preventing the stock from moving backward in relation to the direction of cut. Feather boards can be shop-made or purchased commercially. When ripping stock of a consistent width on the table saw, feather boards will keep the material being fed consistently tight to the rip fence, resulting in a cleaner

sawn edge. Feather boards can also be clamped to the table saw rip fence to keep thin or light material from lifting off the saw table.

A featherboard is easy to make from a piece of hardwood. Do not use plywood as the fingers will break. A bandsaw can quickly cut the fingers. Create lay-out lines, then cut to the line by eyes, they do not have to be perfectly accurate. Featherboards can simply be clamped to the machine table, however in many cases they are easier to place and secure if some provision for affixing them using the mitre track has been planned into their design.

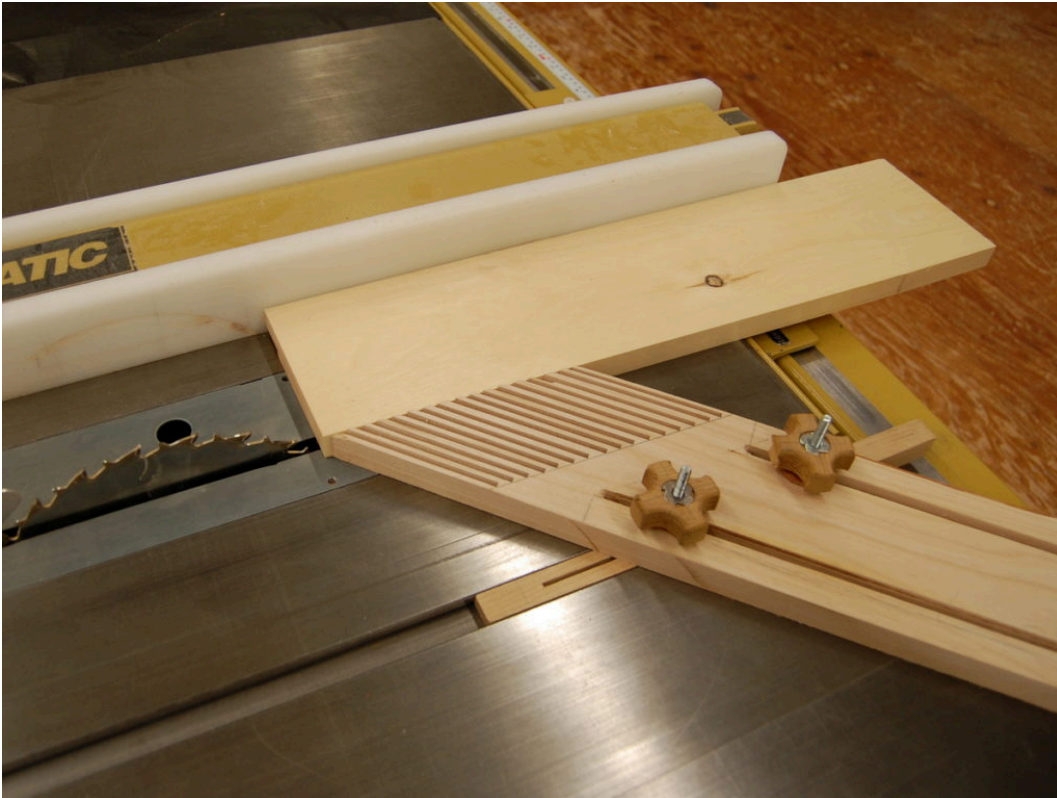

Using a featherboard on the table saw

The featherboard should be located to apply pressure on the infeed portion of the cut. If it is placed adjacent to or behind the blade, it will cause the offcut to pinch the blade and potentially cause a kickback. The only situation where the featherboard can be located behind the blade is when the amount of stock being removed is less than the thickness of the blade, and therefore there is no offcut that would be forced into the saw blade.

Resawing

Resawing is cutting a piece through its width, as in a book match. Resawing of boards up to 6" may be done on a 10" table saw, although if available a band saw set up for this purpose is preferable. Use a rip blade in good condition. A thin kerf rip blade is desirable as it requires less force to push the piece through the saw, and the smaller kerf leaves more material in the workpiece. If the workpiece is much taller than the height of the rip fence, use a tall auxiliary fence for stability. Depending on the width of the piece and the hardness of the material, resawing may need to be done in multiple passes.

For resawing in two passes:

- Set the blade height to barely over one half the width of the workpiece. This will cause the blade to cut the

piece in two.

- Set the rip fence to the desired width.
- If there is a splitter that is higher above the table than the height of the blade, remove it.
- Run the piece through the blade to make the first cut.
- Flip the workpiece end for end, so the same face is against the rip fence.
- Run the piece through a second time. As the cut progresses, it will detach if the depth of cut was set to just greater than half the stock width. Use caution throughout the entire cutting operation, but especially near the end of the cut as the two halves will separate. Use a push stick for narrow stock, and keep your hands clear of the blade at all times.
- Wider and denser stock should be run at multiple depth of cuts to lessen the possibility of kick back from heavy sawing, and reduce possible burning of the workpiece. For example, a 6" board of softwood could be cut in four passes. The blade height would be 1 1/2" for the first two passes, then increased to a full 3" for the second and third passes.
- Another technique for resawing is to set the height of the blade to just less than half the width of the workpiece. The piece will be cut almost all the way through, leaving a small hinge. A chisel can be used to easily break the pieces apart. This technique helps maintain the stability of the workpiece throughout the entire cutting operation as it remains intact. The surface can be cleaned up by planing.

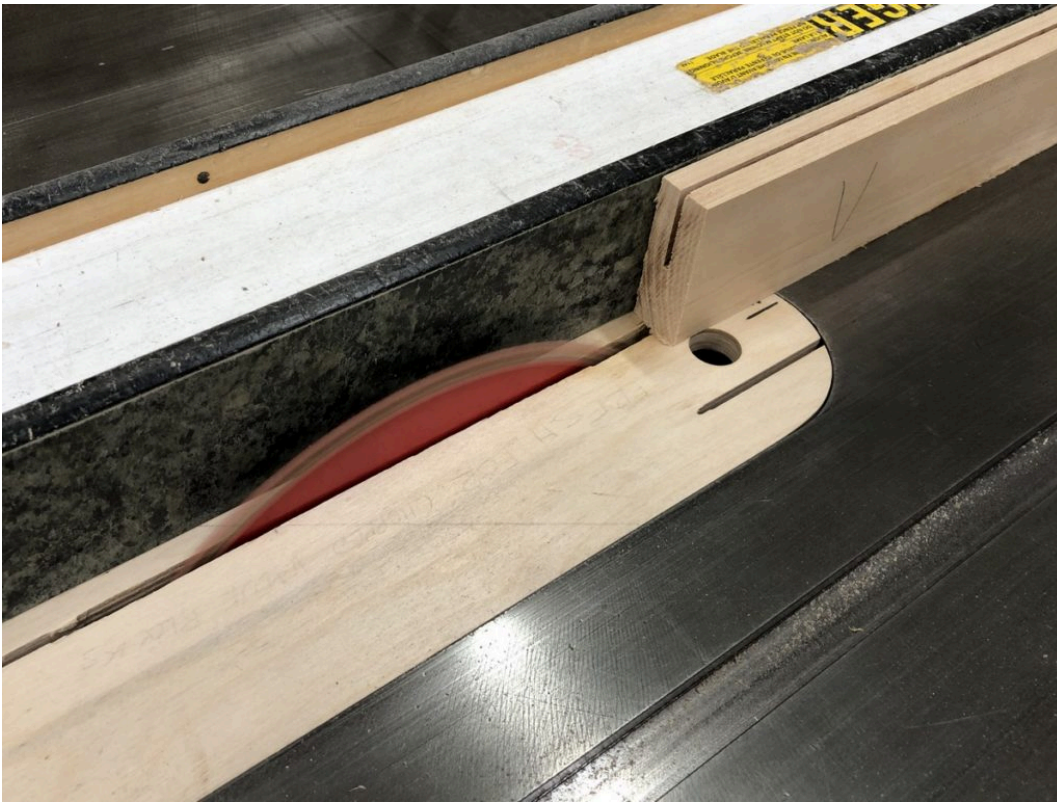

Resawing on the table saw. The second pass is about to be run.

Ripping multiple thin strips:

In certain situations when ripping very narrow strips, such as for edging, a fixture may be used that allows the part being cut to be cut on the left side of the blade. This is done to prevent the narrow piece from being damaged by the saw blade, especially as the cut is completed. These strips are often run through a thickness planer or sander for final sizing.

The fixture is set the desired distance from the left side of the blade. A blank with parallel, straight edges is brought up to the fixture (essentially a stop), the rip fence is then positioned to run the workpiece through at this distance. After each strip is cut, the rip fence is moved to reposition the blank to cut the next strip.



Thin strip rip fixture

Zero clearance auxiliary rip fence

A sacrificial fence for the rip fence is useful for a wide range of operations. In many cases they increase safety and accuracy as well as save the fence from being cut by the blade. This type of fence may simply be a piece of plywood or MDF clamped to the factory fence, or it may be of a box-type that drops over a T style rip fence.



Box style zero clearance auxiliary fence

This fence is often used with dado blades for cutting rabbets. The dado is set up slightly wider than the desired cut, with the extra width buried in the fence. The workpiece is fed against the sacrificial fence. This is safer than trapping the workpiece between the rip fence and the dado cutting on the left edge, especially with a large dado set-up. This set-up eliminates the kickback hazard as the workpiece is not trapped between the fence and the blade.

To get the initial cut in the fence, the blade is lowered underneath the table, the saw started, and the blade slowly raised into the fence. Be sure of the fence position before performing this operation, you do not want to accidentally cut into the rip fence.

Zero clearance dado or rabbet set-up

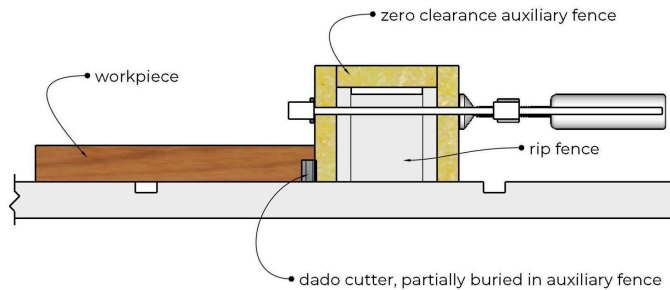

A similar set up can be used to flush trim parts such as solid wood edging on plywood, if the sacrificial fence is stopped short of the machine table, and the left side of the saw blade is flush to the fence.

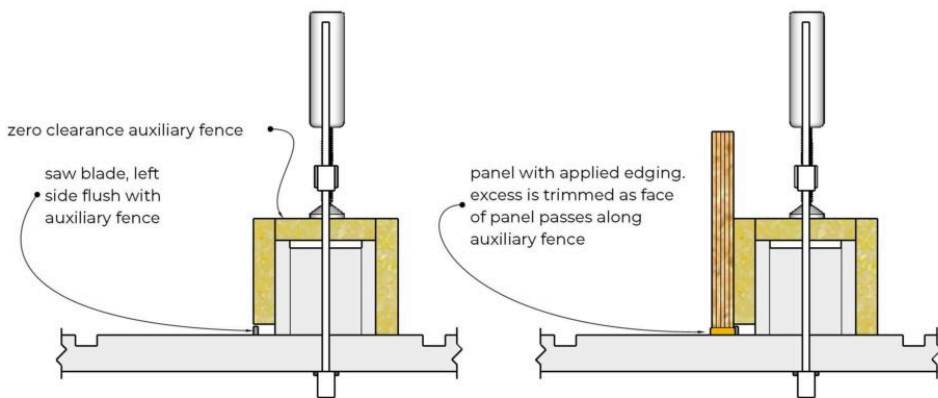

Flush-trimming edging on the table saw

Yet another modification of this type of fence may be used to get a clean edge on a panel that has an overlay such as veneer or plastic laminate applied. Because the overlay overhangs the panel, the edge can not be run directly against the fence. By adding a thin strip to the auxiliary fence, the substrate can accurately reference the fence. This technique is also used on the crosscut fence of the panel saw for trimming large sheets.

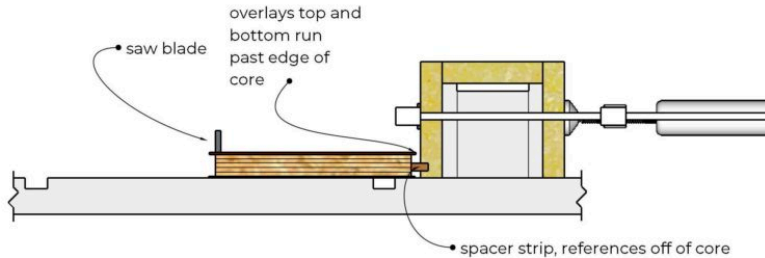

Auxiliary fence for trimming panels with overhanging overlays

Zero clearance for ripping thin stock such as veneer and plastic laminate

Thin material needs to be completely supported by the table to prevent tear-out and shattering. It can have a tendency to get caught on the area around the throat plate, as well as get caught under the rip fence. A thin piece of MDF can be used for zero-clearance. MDF is preferred as it is inexpensive and flatter than plywood. The MDF raises the piece to be cut to a higher position on the rip fence and prevents it getting caught underneath it.



Zero clearance ripping

With the rip fence set, turn on the saw and run the MDF into the blade until it is positioned on the saw table. Turn off the saw and let it come to a complete stop while holding the piece in place. Pull the piece back a few millimeters to prevent the saw from catching it when it is turned on, then clamp it to the table to prevent it from shifting. For small pieces, a length of masking tape along the edge works well to secure it to the table.

Sliding carrier for 'T'-style rip fences

When a workpiece must be oriented vertically as opposed to laying flat on the machine table, a method of safely and securely holding the work must be used. An example is cutting tenon cheeks on the table saw with a rip blade. A simple carrier can be used with the 'T' style rip fence for cutting tenons, beveling small table tops, and many other joinery operations.

As the faces of the 'T'-style fence are parallel, a carrier can be made that uses the rip fence as a guide. If the carrier is built with a tall fence, it can support vertically oriented work pieces such as rails for tenoning. With the addition of a back stop, work may be held at exactly 90° to the blade.



Simple vertical carrier for the T rip fence.



Beveling a small table top with the carrier

The carrier should be constructed of quality plywood or MDF. It is critical that it sits 90° to the table, and slide easily but without play. Clamps can be used to secure the work to the carrier, for multiple repetitive cuts toggle type clamps can be screwed to the jig.

When using clamps on machine jigs, ensure they are heavy duty and secured very tightly. Having a clamp come loose during a cutting operation would be extremely dangerous!

Tenoning jigs

While the above simple shop made carrier can be used for tenoning, dedicated jigs for tenoning can add functionality. Commercially manufactured models use the mitre slot to guide the carrier through the cut. They have adjustments on the jig to set the distance from the blade, some models have both a coarse and fine adjustment. They also have a tilt mechanism for cutting angled tenons. Adding a zero-clearance wood fence on the back prevents tear-out where the saw blade exits the cut.

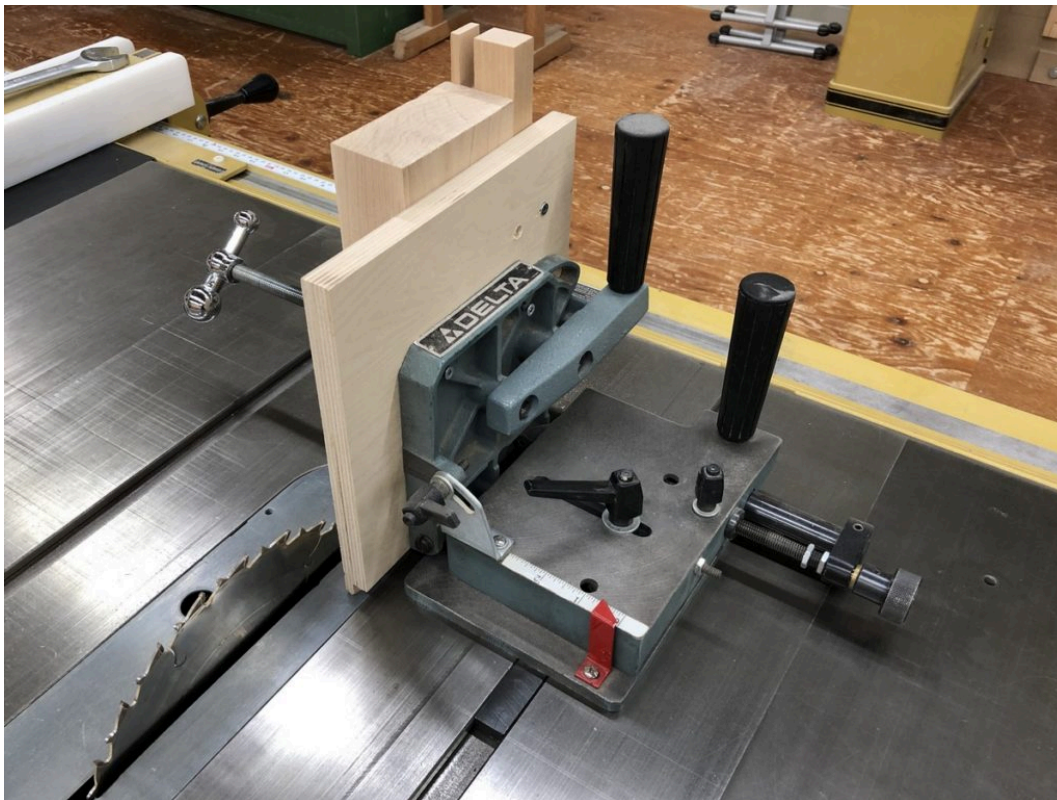

Commercial tenoning jig

For centered tenons, the jig may be set so that rotating the workpiece produces the correct thickness of tenon. Alternately, a spacer can be machined to the thickness of the desired tenon plus the kerf of the blade. Keeping the same face of the workpiece against the fence, one cut is made with the spacer between the workpiece and the fence, and one cut without the spacer. Always check the tenon size on a piece of scrap. This method allows

an accurate tenon size to be cut on pieces of different thicknesses, or to cut off centered tenons without the need to reset the jig.

Tenon jigs can be used for cutting more than just tenons. They work particularly well for cutting open mortises. Two outside cuts are made to define the mortise, then the waste in the middle can be removed by making multiple passes over the saw. The jig can also be paired with dado blades for cutting open mortises or slots in a single pass. Angled cuts on the ends of workpieces, such as for small wedges for through wedged tenons, can also be cut with the tenon jig.

Tapering jigs

A taper jig is guided along the rip fence and simply holds the work at an angle to the blade throughout the cut. There are different types of taper jigs from simple, fixed angle jigs nailed together to adjustable manufactured models.

A simple taper jig can be made by attaching a fence and stop to a rectangle of plywood. These jigs are simple to construct and are useful for pieces that are commonly cut at the same angle, such as wedges, or in the case of a production run of parts that will be reproduced many times over. Toggle type clamps can be added to the plywood base to secure the workpiece which can improve the safety, quality, and accuracy of the cut.

Ensure any clamps or hold-downs clear the blade and are securely fastened.



A dedicated taper jig

For parts that require two tapers, such as a leg that is tapered on all four faces, the jig may be constructed so that one taper is set on either side of the jig. Once one set of tapers is cut, the jig is simply turned 180°.

Most adjustable taper jigs have two long faces with a hinge at the far end, and a clamp or bolt at the operator end for fixing the angle. The face of the jig the workpiece references should have a stop block to push the work through the cut. These jigs take some trial and error to set up, using the mitre slot as a reference can be useful as it indicates the path the blade will cut.



Adjustable taper jig, shown with part in position ready for tapering.

Crosscutting operations

Repeatable cutting of identical parts

One of the most common table saw tasks is crosscutting multiple parts to an identical length. This is accomplished using the mitre gauge or a shop made crosscut tray. The crosscut tray has an advantage as the work is supported by the tray, reducing the chance of it slipping as it is carried through the cut, as well the tray can provide zero clearance cutting on the bottom and back of the cut. The crosscut tray is necessary for cutting larger parts as the mitre gauge is too small for this task. The mitre gauge is well suited for cutting smaller parts and for cutting angles.

With either jig, a stop block is used for accuracy and speed. The part to be cut should first have one end squared before being set against the stop block for cutting to final length. Normally, the piece is squared on one side of the blade (usually the left) before being slid to the other side to be cut to length against the stop block. In this way, an efficient work flow is created. This process can be somewhat easier with a crosscut tray as it has a longer fence and is guided by both the mitre slots. The same workflow can be created with the mitre gauge if a sturdy auxiliary fence is added and the pieces are small.

Crosscutting with a stop block

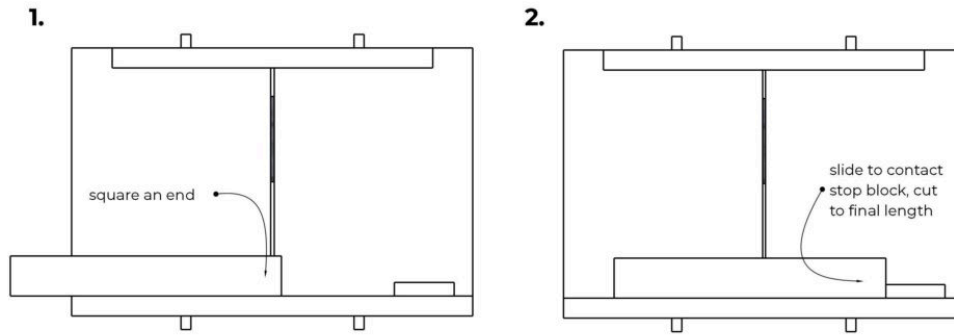

If the parts to be cut are longer than the fence, the rip fence may be used as a movable stop if it is set up to provide clearance to the offcut. A block of wood is clamped to the rip fence well back from the blade. The block serves as the stop for the part being cut without trapping it between the blade and the fence. It is important that the block be of a thickness so that clearance for the offcut will allow it to spin freely if it catches the blade.

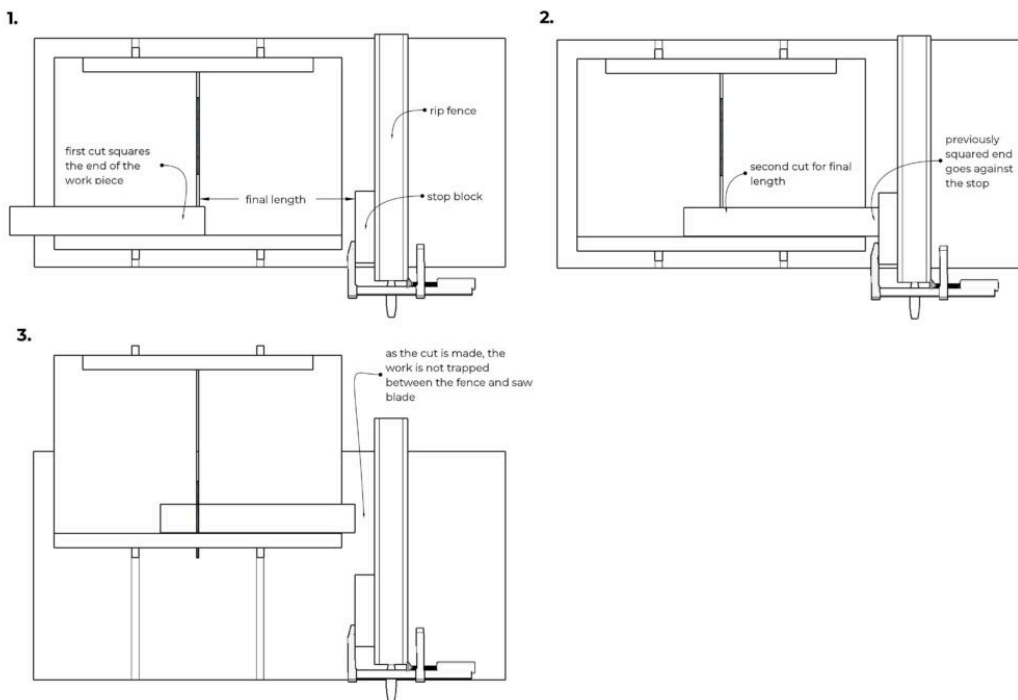

Using the rip fence as a stop when crosscutting

Never use the rip fence as a stop with a crosscut tray or mitre gauge. The workpiece can bind between the fence and blade and kick back at you.

Face mitring accurate 45° angles

Adapting a sliding tray for cutting mitres across the face is done by first attaching a straight fence to the base of the tray at 45° to the saw blade path. Using a plastic drafting set square assists accuracy. Allow the wood to overhang the blade path to be trimmed later.

A second fence is fastened to the base of the tray at 90° to the first one, not at 45° to the other side of the blade. This concept of ensuring that fences are truly square with one another rather than aligning the second at 45° to the blade path will help make a better mitre joint.

The final remaining step is to trim the two fences by running the tray over the saw. The newly mitred ends of the fences will then give a very accurate location for the saw blade path. This enables workpieces which are marked with a sharp pencil to be lined up on either the inside or outside edge of the wooden fence strips. Gluing sandpaper on the fence edges will help prevent the wood slipping as it is cut. If you are making two or more boards the same length, a stop block will ensure accuracy and always result in a better fitting mitre joint.

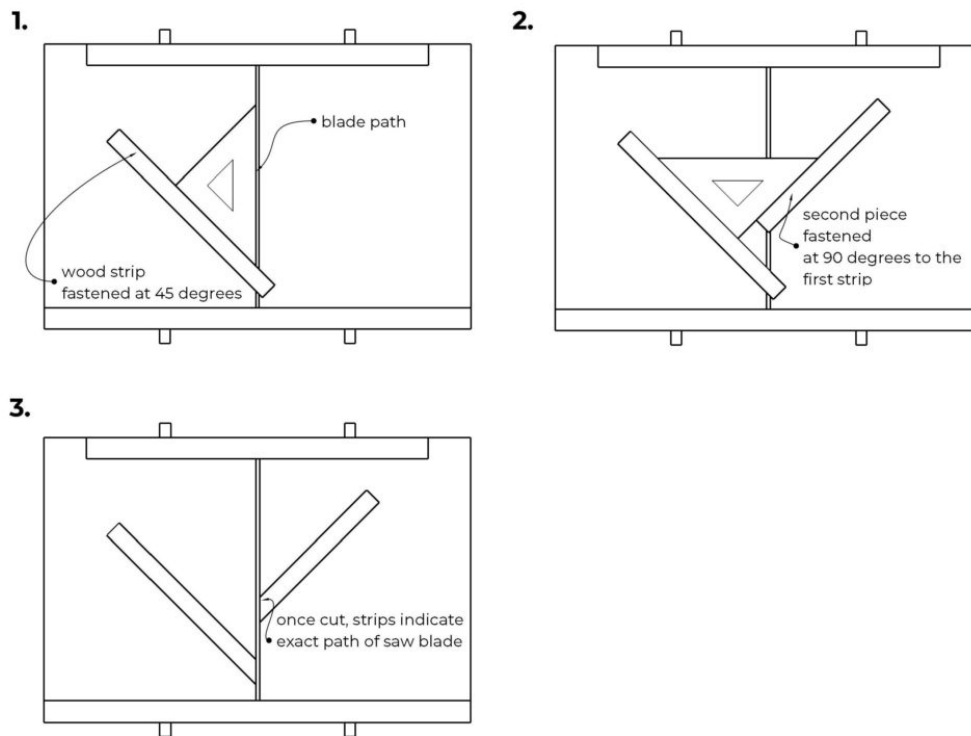

Mitering on the table saw with a crosscut tray

End Mitering with the blade tilted

When mitring across the ends of a workpiece, as in cabinet and box construction, it is necessary to use the blade tilt on the table saw. A crosscut tray dedicated to this purpose can be useful if this type of cut is performed often. It can also be done with a mitre gauge, however the crosscut tray has the advantage of supporting the work in a way that prevents it from sliding on the table. If the mitre to be cut has one half of the joint cut on the left of the saw, and the other half on the right side of the saw, the pieces will come together perfectly

at 90°. This method ensures the angles will be **supplementary**. The only disadvantage of this method is one half of the joint will be cut face down, with the potential of tear-out at the toe of the mitre. However, installing a zero-clearance backer and using a sharp crosscut or combination blade can eliminate tear-out.

Sliding Table (Panel) Saw: Common Operations

Ripping

As with the cabinet saw, ripping is done with the rip fence to guide the work. However, the location of the crosscut fence can impede the offcut. It is important to move the sliding table forward so the offcut is free and the cut is complete before reaching the crosscut fence. This works well for smaller pieces. For larger, longer work, the sliding table can support the work and travel with the workpiece as long as the end of the piece being cut does not contact the crosscut fence.



Ripping a full sheet on the panel saw

With the location of the chassis on larger panel saws, ripping using the rip fence can be an awkward operation as the operator must stand to the left of the sliding table and a significant distance from the rip fence. Whenever possible, use the sliding table and crosscut fence for making wide rip cuts in panels. The rip fence can be set to the desired width of cut and be used as long as the fence extrusion is set about 50 mm before the leading edge of the blade. In this way, the offcut is free as the cut is complete and not trapped between the fence and the blade. To use the crosscut fence while using rip fence in this manner, they must be in perfect 90° alignment.



Using the rip and crosscut fence together

Straight line ripping

The sliding table saw may be used to easily cut a straight edge on long narrow stock. Solid lumber with severe bowing or natural edges can be straightened quickly and accurately. An accessory known as a wedge or shoe is included with many saws to stabilize and clamp the end of the workpiece for this operation. The shoe clamps in the mitre slot in the sliding table, when forward pressure is put on the workpiece it is held tight to the table. If a shoe is not available, a flip stop may be used to reference the work on the crosscut fence. Always use extreme caution when using the crosscut fence for ripping narrow pieces as there is little support. Use clamps or hold-downs if necessary. Always use the proper blade for ripping solid wood.



Straight line ripping on the panel saw

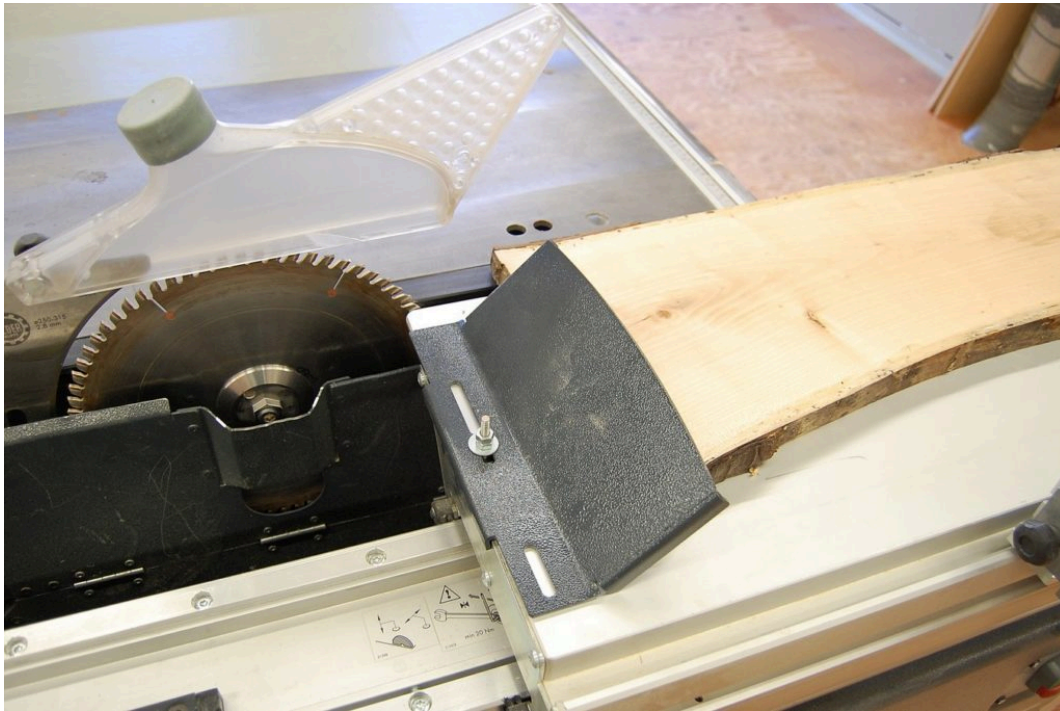

Panel saw ripping shoe

Crosscutting

With a long crosscut fence and flip stops, the panel saw is well suited for cut-off work. The procedure is different than on a cabinet saw as the workpiece is always on the same side of the blade. The flip stops make it possible

to square an end and cut to an accurate final length on multiple parts. The rip fence can also be used as a stop for cutting parts to length, and is the preferred method when the pieces to be cut are short.

To crosscut multiple parts to length using the flip stop:

- Set the flip stop to the desired final length.
- Move the flip stop up and out of the way. Crosscut a small amount off of one end of the workpiece to square the end.
- Flip the stop down on the crosscut fence.
- Rotate the workpiece 180° so the squared end is against the stop.
- Cut the piece to length.



Using the crosscut fence and flip stop

To crosscut parts to the same length using the rip fence:

- Set the rip fence to the desired length.
- Slide the aluminum extrusion back so the end is about 50 mm from the leading edge of the blade.
- Using the crosscut fence, square the end of the workpiece.
- Move the sliding table back so that the workpiece may be safely slid over the table and make contact with the rip fence. Use extreme caution if the scoring blade is in use.
- Hold the workpiece tightly against the crosscut fence and cut to final length.
- The part cut to length will be the 'offcut', and will be sitting on the table. Use caution when removing it from the saw, do not reach around the saw blade with your hand to retrieve it.
- It is acceptable to cut a small number of parts before moving them away from the blade. Power off the saw before clearing them, or use a stick to push them clear of the blade. Do not allow a build-up of parts as they may catch the blade and kick back.
- As you near the end of the piece being cut, it will become too short to safely reference off the crosscut fence. Either waste the end of the piece (if acceptable), or set the flip stop and cut the remainder as

outlined above.



Crosscutting using the rip fence as a stop

Cutting full sheets to size

While all types of machining operations can be done with the sliding table saw, this machine excels at quickly and accurately breaking down large panels and cutting to exact final size. Depending on the cutting plan and part sizes, the cutting sequence can vary. While factory edges are usually trimmed from the sheet first, in some cases it may be advantageous to do initial rips or crosscuts before cutting factory edges and to final sizes.

A typical cutting sequence on a 4'x8' panel would be to trim the factory edge on one end and one edge first to square the sheet and obtain a clean edge. Then, using the rip fence and flip stops for accurate sizes, the sheet would be cut into parts. It is common practice to do the rip cuts first, cutting to final width before using the crosscut fence to cut to final length. Larger parts are usually cut out of the sheet first, and smaller parts are then cut out of smaller pieces and offcuts.

To square a sheet and remove the factory edges:

- Place the sheet with the long edge against the crosscut fence
- Trim about 3 mm off the end of the sheet.
- Rotate the sheet so the just-trimmed end is against the crosscut fence. Make sure it is tight to the fence or the panel will not be square.
- Trim off about 3 mm from the long edge.
- The sheet may now be cut using these clean, square edges for referencing the remaining cuts.

When cutting sheet goods with veneer, melamine or laminates, the scoring blade should be used to prevent tear-out on the bottom of the panel.

Use extreme caution when the scoring blade is in operation as the small amount it protrudes from the table makes it impossible to see the rotating blade.

Zero clearance sub-table for tapering and angle cuts

A zero clearance sub-table affixed to the sliding table can be a versatile addition to the panel saw. Fences and toggle clamps or other hold-downs can be attached to this table that allow for a variety of tapering operations. Precise angled cuts can also be made. While the crosscut fence can be angled, the use of a sub-table allows for quick set-up and the use of fences and stop blocks that easily and safely position the work. Dedicated jigs for production work can be made that index off the mitre slot and can be quickly and accurately positioned on the saw.

The sub-table may be made out of MDF or a stable plywood such as Baltic birch. A wooden or plastic runner can be screwed to the sub-table to allow perfect positioning every time. The initial construction of the table should allow for material to be trimmed off the first time it is used, ensuring the sub-table is in perfect alignment with the blade.

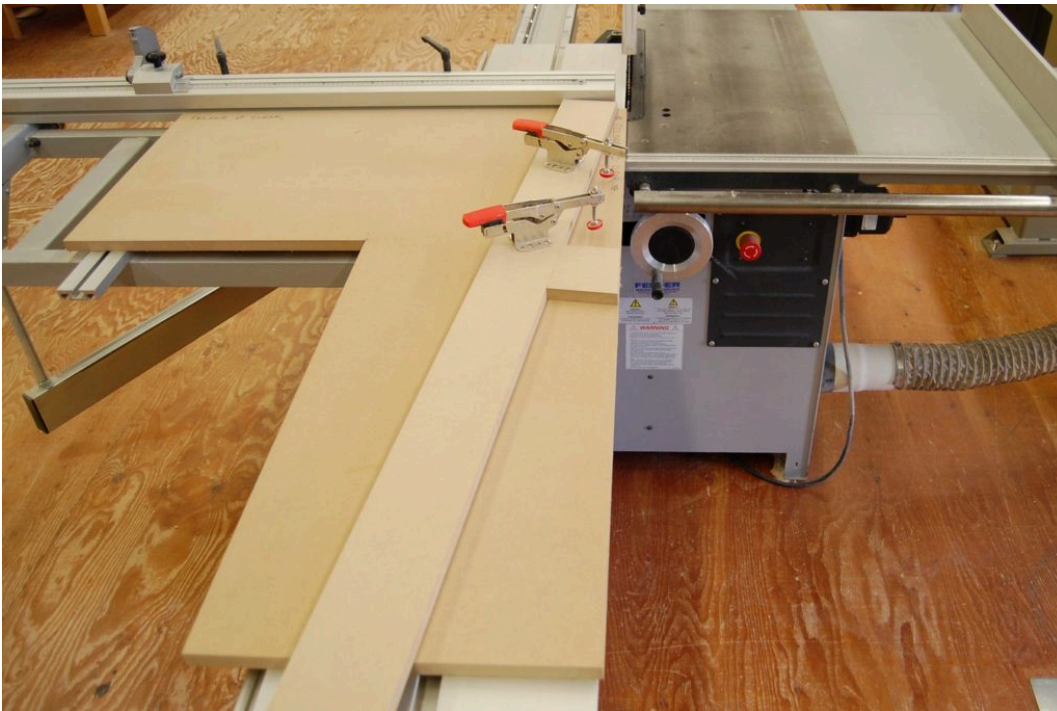

Panel saw zero clearance table

5. Set Up and Maintenance



One or more interactive elements has been excluded from this version of the text. You can view them online here: <https://pressbooks.bccampus.ca/woodworkingmachinery/?p=101#oembed-1>

All machines require set up to achieve accurate and repeatable results, and maintenance to keep them working properly. The following information will guide you through these tasks. Learning to properly set up and tune the machinery you use on a daily basis is important in keeping the entire shop efficient and productive.

In all aspects of set up and maintenance, use correct lock out procedures before beginning.

Setting the blade to 90° to the table

One method to set and check the blade for square is to use a reliable engineer's square. Raise the blade out of the table at least 50 mm or 2". The greater the height of the blade out of the table, the more accurate the reading will be. With the throat plate in place, set the square on the table on the side of the blade that is closer to the table. This allows for the best support of the square on the table reference surface. Make sure the square is roughly centred and perpendicular to the blade. Gently slide the square up to the plate of the saw blade, ensuring it makes contact between and not on the carbide teeth. Standing directly in front of the blade, look for light showing between the square and the blade. If there is light the blade is not square, use the tilt handwheel to bring the blade into alignment with the square. It is always advisable to make a test cut to confirm. A sliding T bevel can be used in the same manner to set accurate angles.

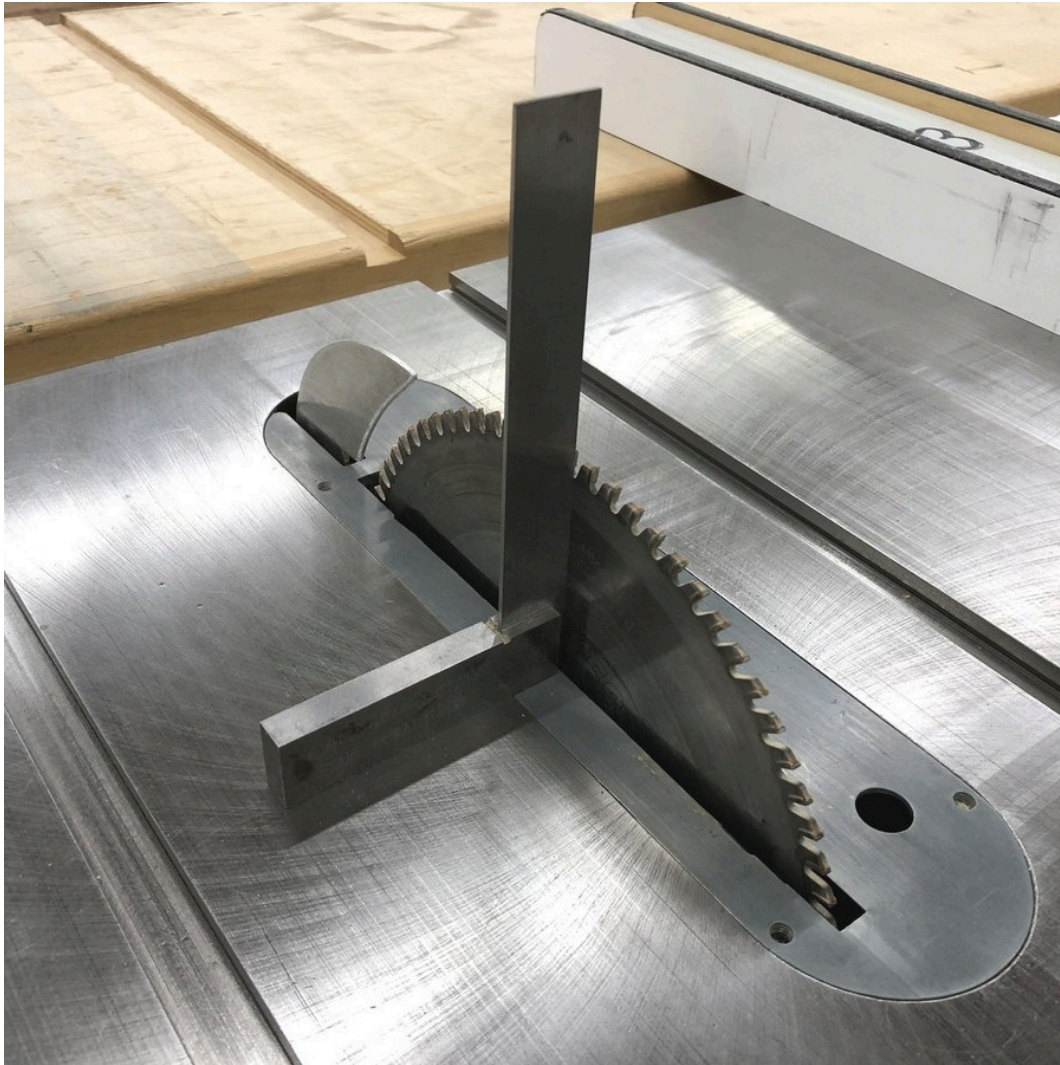

Checking for square with an engineer's square

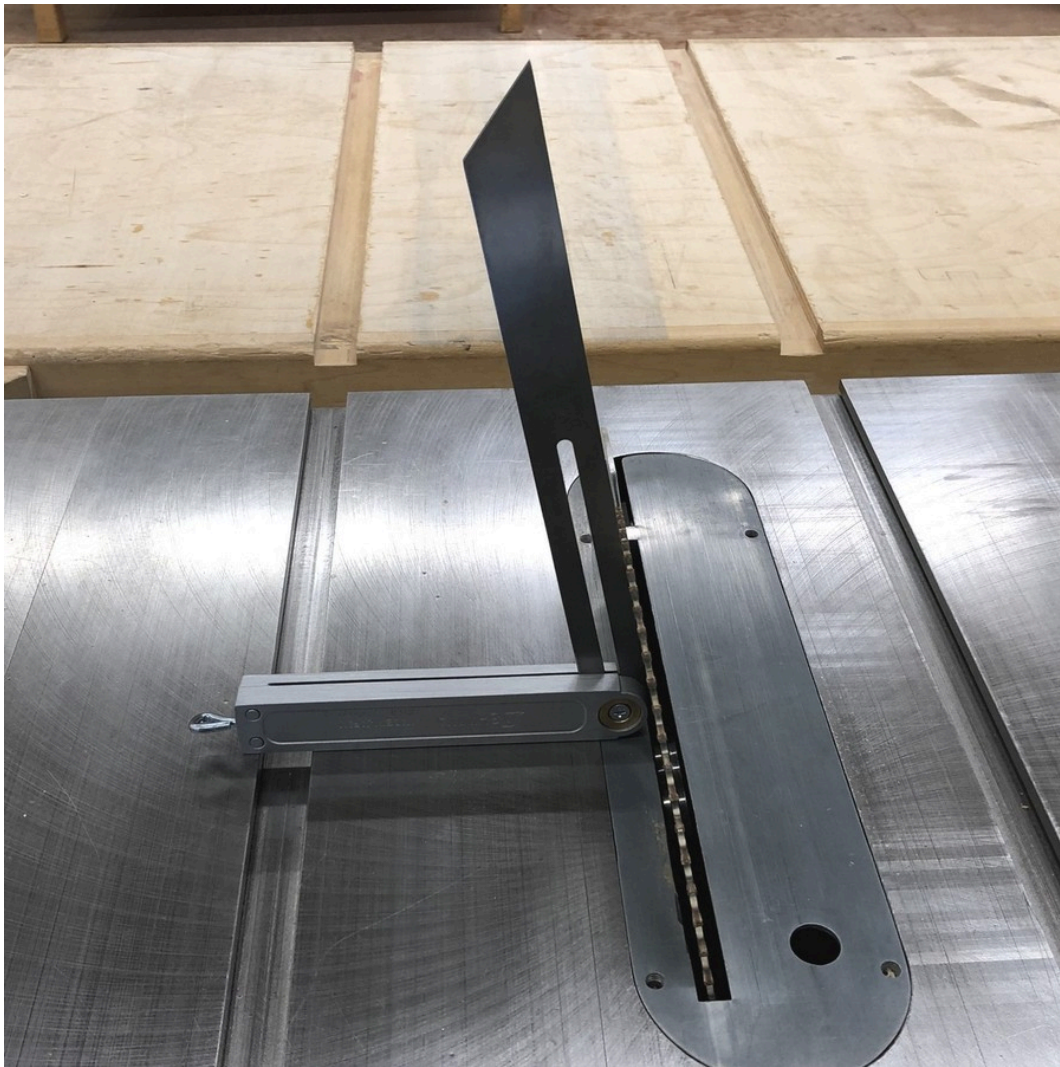

Setting an angle with a sliding T bevel

Setting the mitre gauge to 45° or 90° to the blade

While many mitre gauges have a positive stop for both 45° and 90°, it is necessary to confirm them for accuracy. Using a large 45° drafting set square, place the square against the fence of the mitre gauge and gently bring it into contact with the blade. The blade should be fully raised out of the table to begin, and rotated as needed to ensure the set square is contacting the plate of the blade only, not the carbide teeth. If the set square contacts the blade along its length, the gauge is set. Depending on the type of blade used, it can be difficult to rotate the blade to a position where just the plate makes contact, in this case the blade can be rotated so the set square makes contact with the saw teeth only. If adjustments are required, make them and then adjust the 45° and 90° positive stop on the miter gauge to recalibrate it for future use. This adjustment will be slightly different depending on the brand of mitre gauge, it is usually done by adjusting a small set or Allen screw on the stop.



Checking the mitre gauge for 45°

The only reliable way of checking if the machine is accurately set to 90° or any other angle is by making test cuts. This is especially important when setting up to cut any mitres. Use a piece of scrap to mitre four pieces into a square to confirm the corners are perfect. It is worth the time and effort.

Rip Fence Calibration

Constant parallel fences all come with a measuring tape built on to the fence rail. They should be checked periodically for accuracy. Once a blade is installed on the saw a test cut is made through a scrap piece of wood run along the fence. The freshly sawn scrap is then carefully measured and the fence calibrated to the exact measurement. On a 'T' style fence this is achieved with the adjustable cursor, a piece of clear plastic with an inscribed indicator line. A European style fence reads directly off the face of the rip fence, calibration is made by loosening the tape and adjusting it as needed.

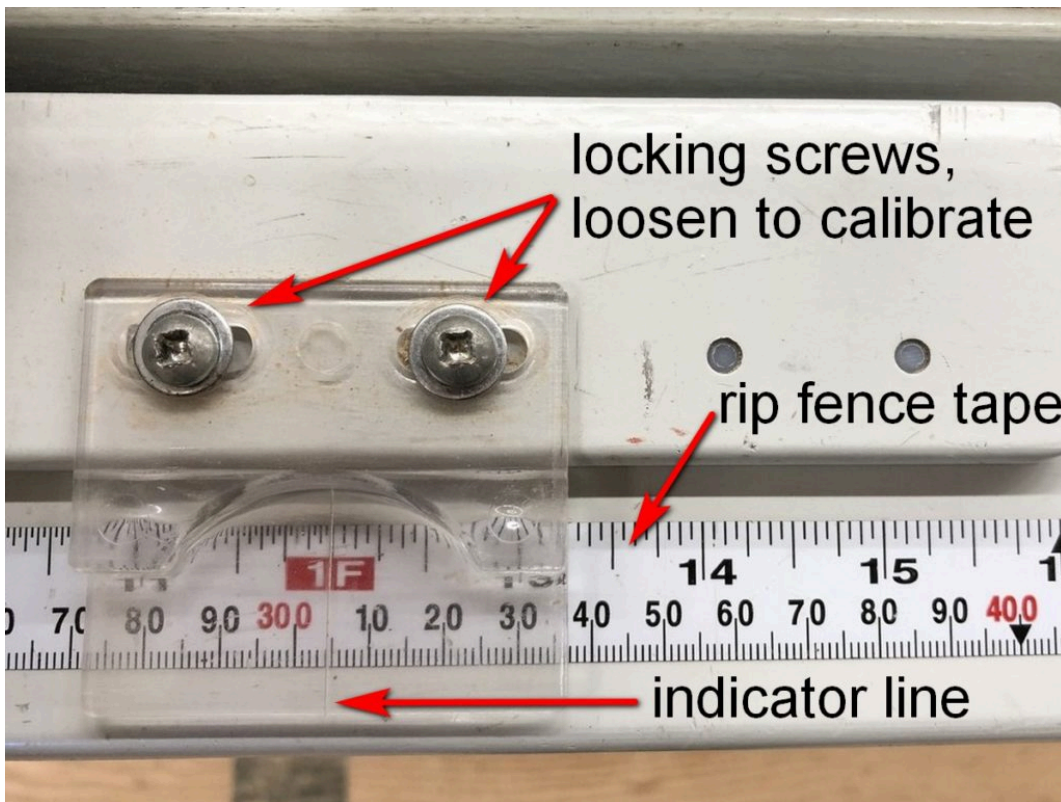

Once the fence has been calibrated in this manner, it can be reliably set without switching the motor off and waiting for the blade to stop turning before a new setting can be measured. Being able to trust the fence setting is essential for accurate and efficient operation, and reduces wear on the electrical parts of the saw as it isn't being switched off and on repeatedly.

It is important to note with modern left-tilt table saws that when the saw blade is installed, it references the left side of the saw blade against the arbor washer. Because the rip fence is to the right of the blade, changing between thin kerf ($3/32$ ") and standard saw blades ($1/8$ ") will throw off the calibration of the rip fence depending on what thickness of blade was installed in the saw when the fence was calibrated.

Cleaning & dressing the table

Over time, machine tables get dirty and may accumulate small amounts of pitch and other contaminants. This increases friction, which requires the operator to apply more force to feed the work. Occasionally, the cast iron table may get small burrs and nicks, usually as a result of metal objects such as staples, brads or screws coming into contact with the table. These can scratch and catch on the workpiece.

To dress the table and remove any burrs and nicks, use a smooth, flat file to remove them. Keep the file flat on the table with light pressure while sliding it forward. This is usually sufficient to remove them.

To clean the table, use 400x silicon carbide wet-dry sandpaper or steel wool, adding mineral spirits as a cleaner and lubricant. Wet sand the entire surface, then wipe the solvent and grime away with a dry cloth. Apply a thin coating of paste wax, let dry then buff with a dry cloth. Wax the rip fence as well. It is usually necessary to clean and wax the table after machining a quantity of wet wood, such as construction lumber, or lumber that is particularly pitchy, such as pine. Cast iron rusts easily, and any moisture will quickly create a rough surface.

The addition of paste wax also helps to prevent moisture from damaging the table. After dressing the table, it is noticeably easier to feed material through the saw. This maintenance should be performed monthly or as required.

Cleaning and lubricating height and bevel adjustments

Fine sawdust and pitch residue can quickly build up on the moving parts of the saw. This creates friction and resistance in the screw that controls the height and bevel, making it difficult to move the adjusting handwheels.

To clean these parts, lock out the saw and open the cabinet to access the mechanism. Using a vacuum, remove the dust from the leadscrews and surrounding parts, then finish with compressed air. It is advisable to have the dust collection on and wear PPE such as an approved respirator or dust mask as this creates fine particulate. If the leadscrew is packed with dust, contaminated with pitch or is excessively dirty, a soft brass wire brush may be used to remove the material.

Because space is limited, it can be difficult to access the necessary parts. You will need to adjust the height and bevel to get to the leadscrew. In some cases, you can access the mechanisms from the cut-out in the front of the cabinet where the bevel scale is, and from the throat opening in the table with the blade removed. At the same time you clean and lubricate the height and bevel leadscrews, lubricate the trunnions at the front and back of the saw.

Do not use machine oil or a product such as WD-40™ as a lubricant as it attracts excessive amounts of dust and quickly become loaded with sawdust. White lithium grease is recommended as it attracts less sawdust and adequately lubricates the parts.

Cleaning saw blades

Blades need to be cleaned of the pitch and residue they accumulate. A dirty saw blade does not cut as well as a clean one. Dirty blades also tend to cause burning as they cut from increased friction. If a blade seems dull, it may just need to be cleaned.

Commercial blade cleaners are available that soften the residue. A citrus based cleaner or oven cleaner also work well.

- Place the blade(s) in a container or on a piece of cardboard.
- Apply the cleaner, and allow it to sit for a period of time to loosen the residue.
- Use a stiff nylon bristle brush or green scrubby pad to remove the residue.
- Rinse with water, and dry well with a cloth to prevent corrosion before storage,

Checking the mitre slots to the saw blade for parallel

If the mitre slots in the main table are not parallel to the blade, accurate cuts will not be possible as the stock will not travel in a straight line past the blade, resulting in out of square cuts. Rough cuts and burning are also an indication that the slots may be out of alignment. When purchasing any new or used saw, it is a good idea to check this alignment and adjust it if necessary.

Dial Indicator

To check for alignment, you will need a dial indicator, which is a precision measurement tool used for measuring small distances and angles. It is useful for setting up and checking shop machinery and equipment. Models are available with magnetic bases that will easily attach to machinery tables.



Dial indicator with magnetic base

To check for alignment, perform the following steps.

- Lock out the saw, install the largest blade the saw will take, and raise it to full height above the table.
- Put the mitre gauge in the slot it is most used in. Make sure the miter gauge has no play in the slot.
- Install the indicator in approximate position as follows. If your dial indicator has a magnetic base, attach it to the mitre gauge. You may need to remove the wooden auxiliary fence. If your dial indicator is not magnetic, attach it to a block of wood, and clamp the block to the miter gauge. In both cases, the tip of the indicator should be close to and pointed toward the blade.
- Slide the dial indicator so it makes contact with the plate of the saw blade, close to but not touching the teeth. The farther the measurement is made from the centre of the blade, the more accurate it will be. The indicator should be engaged so it makes a few turns of the dial.
- Starting closest to you at the front of the blade, mark the location on the saw blade where the tip of the dial indicator touches.
- Zero the dial indicator.
- Slide the mitre gauge with the attached dial indicator to the back of the saw blade.
- Rotate the saw blade until the mark you made is at the point of the dial indicator.
- Note the measurement.
- If the indicator stays on zero, the mitre slots are in alignment with the blade. If the indicator moved, the

slots are out by the amount of the second measurement.

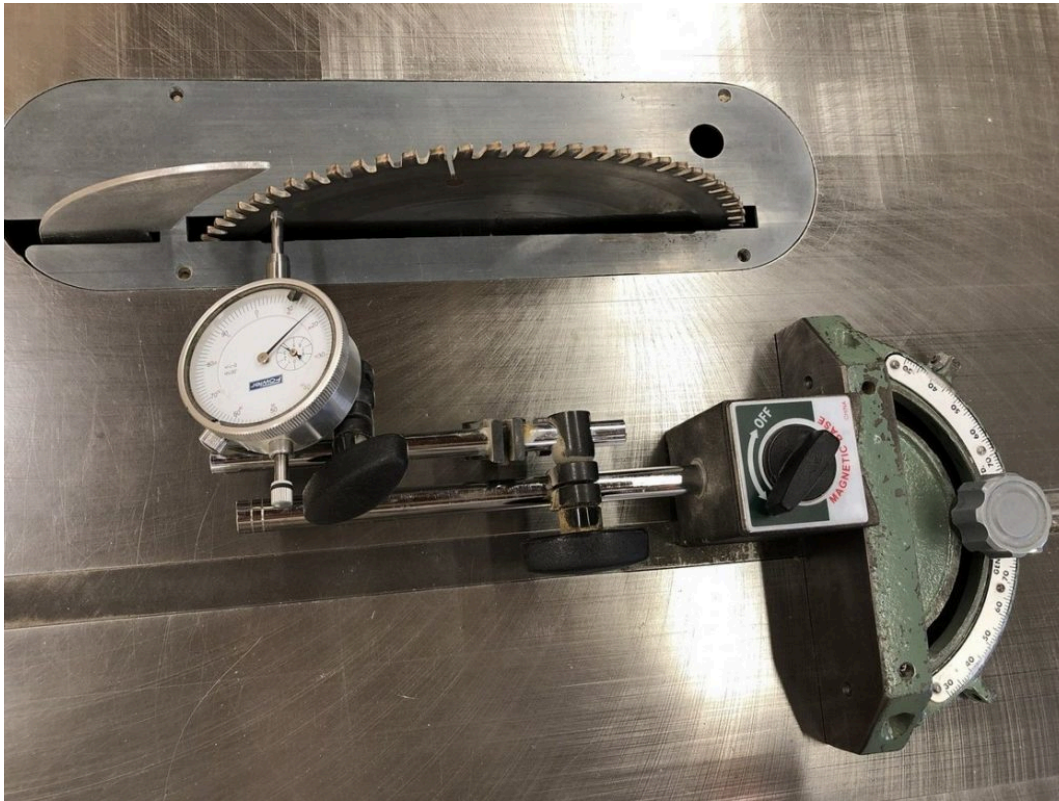

*Checking alignment:
dial indicator in
position for the
second reading*

To make the necessary adjustments, follow the steps below.

- On a cabinet saw, find and just-loosen the bolts that fasten the table top to the cabinet. It is easiest to loosen 3 bolts and use the last as a pivot point.
- Use a mallet to tap the table in the direction it needs to move to bring it into alignment.
- Use the dial indicator to re-measure for alignment. You will need to zero the dial indicator.
- Keep adjusting the table, remembering to zero out the dial indicator each time.
- When the slots are aligned, tighten the table bolts.
- With the bolts tight, check the alignment one final time to ensure tightening the bolts did not affect the alignment.

Adjusting the rip fence (T-style) to the blade

The procedure for checking alignment of the rip fence to the blade is similar to checking the mitre slots for parallel.

- Lock out the saw, install the largest blade the saw will take, and raise it to full height above the table.
- Position a dial indicator against the rip fence. The tip of the indicator should be close to and pointed toward the blade.
- Position the rip fence so that the dial indicator makes contact with the plate of the saw blade, close to but not touching the teeth. The farther the measurement is made from the centre of the blade, the more

accurate it will be. The indicator should be engaged so it makes a few turns of the dial.

- Starting closest to you at the front of the blade, mark the location on the saw blade where the tip of the dial indicator touches.
- Zero the dial indicator.
- Slide the dial indicator to the back of the saw blade.
- Rotate the saw blade until the mark you made is at the point of the dial indicator.
- Note the measurement.
- If the indicator stays on zero, the fence is in alignment with the blade. If the indicator moved, the fence is out by the amount of the second measurement.

To make the necessary adjustments in a 'T' style fence, follow the steps below.

- With the fence on the saw, note which way it needs to pivot to bring it into alignment.
- Unlock the fence and flip it over on the saw table.
- Using a hex wrench, adjust the set screws to move the fence in the direction it needs to move.
- Install the fence on the saw, and check for parallel with the dial indicator.
- Keep adjusting and checking the fence until it is parallel to the blade.



Adjusting a T style rip fence for parallel

Setting and adjusting the positive 90° and 45° stops

Every table saw has stops that limit the travel of the trunnion assembly at 90° and 45°. Having these accurately set saves time with set-up and improves accuracy. Occasionally, they may need to be adjusted. If the saw is not reliably returning to 90° and 45°, first check that there is no debris or sawdust built up on the stops or on the trunnion assembly.

To make the necessary adjustments, follow the steps below.

- Lock out the saw, install the largest blade the saw will take, and raise it to full height above the table.
- Using an engineer's square or a reliable 45° measuring tool such as a drafting set square, set the blade to the appropriate angle.
- Ensure the square is touching the plate of the saw blade, not the carbide teeth. Use the tilt handwheel to bring the blade into perfect alignment with the square.
- Locate the lock nut for the positive stop. Refer to the tool's manual if required.
- Loosen the nut and adjust it until it contacts the trunnion assembly in the correct location. Depending on which way the stop needs to move, it may be necessary to use the tilt handwheel and swing the assembly out of the way to provide clearance.
- Tighten the nut, then tilt the saw a few degrees before returning it to position against the stop.
- Check the angle to confirm the stop location, you may have to try a few times to get a reliable reading.
- Make a test cut in a piece of wood, this is the most reliable way to check the setting.

Electrical and drive belts

Periodically inspect the power cord and electrical wiring for damage or fraying. Check the plug for loose connections. A qualified electrician should repair electrical issues on any machinery.

With use, the drive belts on any machine will wear out. A worn or damaged belt causes undesirable vibration. Look for hardness, cracking, and fraying; replace the belts as needed. Most table saws use a pair of belts, these should be replaced at the same time. Proper tension on the belts is important, too-tight belts puts unnecessary strain on the pulley and arbor bearings. A too-loose belt will result in slippage and the saw losing power, possibly stalling in the cut.

To check the belt tension, push on the belt at the midpoint between the pulleys, it should flex slightly. With the saw locked out, it should be possible to turn the saw blade easily by hand.

PART II

JOINTER

The jointer is used for the initial stages of machining solid wood. Most of the wood used in the joinery or cabinetmaking shop arrives as rough lumber which is rarely accurate enough to use as is. For accurate and tight fitting joinery, straight, square stock is essential. Even if the stock has been properly surfaced and squared, if left for a period of time, solid wood will continue to move as it comes into equilibrium with the ambient humidity. Tension is released in solid wood as it is further cut to size, often necessitating re-machining.

The purpose of the jointer is to create a flat, true surface free of bow, twist or cup, and to create a straight, square edge relative to a jointed (flat) face. The jointer can also be used for small sizing jobs, (such as fitting cabinet doors), to cut tapers and bevels, and for cutting rabbets (such as for door jambs).

6. Parts of the Jointer



One or more interactive elements has been excluded from this version of the text. You can view them online here: <https://pressbooks.bccampus.ca/woodworkingmachinery/?p=124#oembed-1>

Parts of the jointer

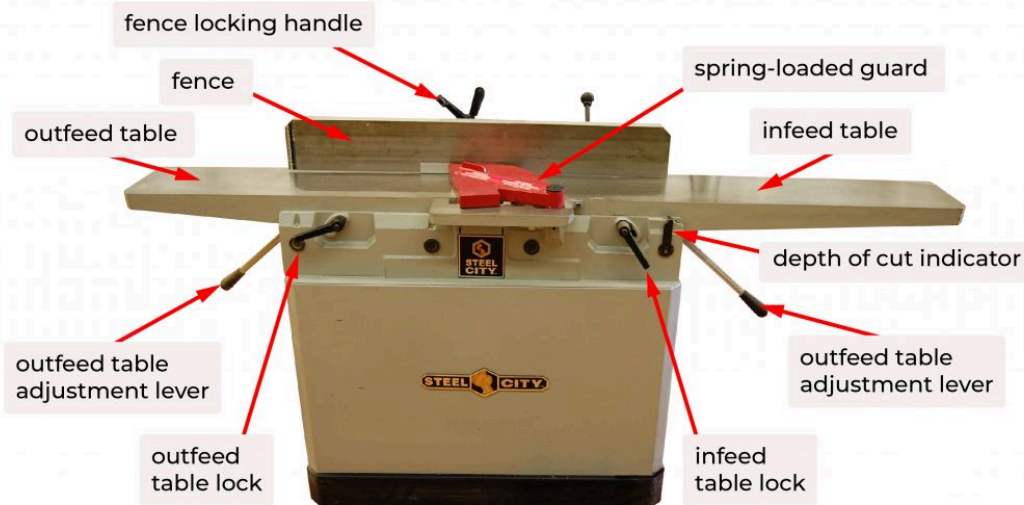

Infeed table

The infeed table supports the workpiece as it passes over the cutterhead. Both the infeed and outfeed tables are made of cast iron, and should be dead flat and parallel to each other. They move in relation to the cutterhead, which is fixed to the base. The position of the infeed table relative to the cutterhead determines the depth of cut. The lower the table below the cutterhead, the greater the depth of cut.

Infeed table height adjustment

The infeed table height adjustment is made via a handwheel or a lever, depending on how the tables are designed to move. The table should be locked after the height is set, usually with a 'T' handle.

Depth of cut indicator

Most jointers have a depth of cut indicator, consisting of a gauge and pointer. They are not very accurate, and need to be calibrated every time straight knives are changed. Use these as a rough estimate only. If the depth of cut is critical, run a piece of scrap wood about 50 mm into the cutterhead, then carefully pull it back out of the cut. The gap between the bed and the workpiece is the exact depth of cut. Alternately, lock out the machine

and place a straight edge on the outfeed table. The difference in height between the infeed and outfeed table is the depth of cut.

Outfeed table

The outfeed table supports the just-machined surface as it clears the cutterhead. Its position relative to the cutterhead must be set perfectly for the jointer to function properly.

Outfeed table height adjustment

The outfeed table is adjusted in the same manner as the infeed table. The outfeed table should only be adjusted when the knives or cutters are being changed, or if the jointer is not cutting properly. Ensure the outfeed table is securely locked to the base once it has been adjusted.

Dovetail ways or pivoting arms

The tables are fixed to the base by means of dovetail ways or pivoting arms. On a machine with dovetail ways, the base casting has a sloped surface with a precision machined dovetail shaped casting. The table is likewise machined with the matching profile. The two halves slide together in direct contact, and should be set up to have very little play between the base casing and tables. This allows the tables to move, but keeps things in alignment.

Jointer with dovetail way adjustments



Many European jointers use a system of pivoting, parallel arms to connect the base to the tables. In both cases, the alignment between the tables and the base must be exact for the jointer to perform perfectly. Refer to the machine's manual if adjustment is required to bring the tables and base into alignment.



Jointer with pivoting arm adjustments

Fence

The jointer fence is used to keep the workpiece in position as it is fed through the machine. There are two main adjustments on the fence, lock and tilt. Different makes of jointers use varying fence systems, they all have the same basic adjustments.

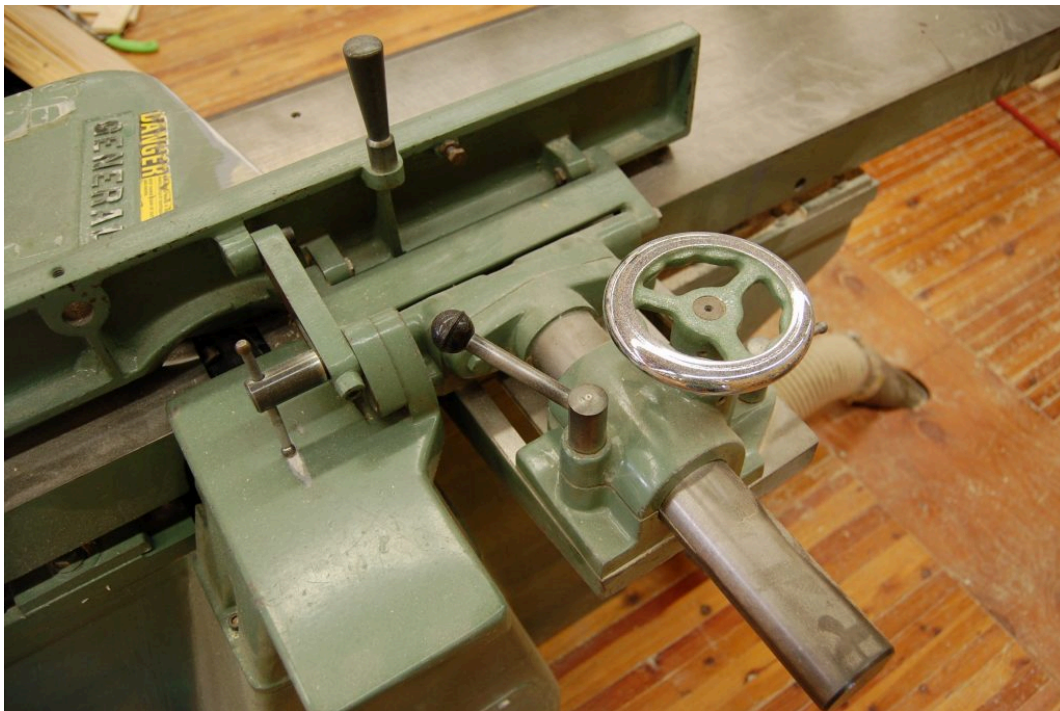

General 780 jointer fence

Fence lock

The fence may be moved laterally across the table and locked in place at any point along the length of the cutterhead. When narrow stock is being jointed, it is desirable to position the fence near the operator to reduce the need to lean over the machine. Occasionally, the knives may have minor nicks that leave tracks in the machined surfaces, the fence can be placed to avoid these areas.

Fence tilt

This adjusts the angle of the fence relative to the tables. This is the adjustment for square, and to tilt the fence for cutting bevels. Many jointers have a positive stop for 90°, this should be checked for accuracy periodically. Use an engineer's square placed on the outfeed table just past the cutterhead. Always check by cutting a test piece before proceeding.

Another way of confirming the machine is cutting square is to edge joint two pieces. With the faces that were against the fence laying flat on the machine table, the edges should line up perfectly.

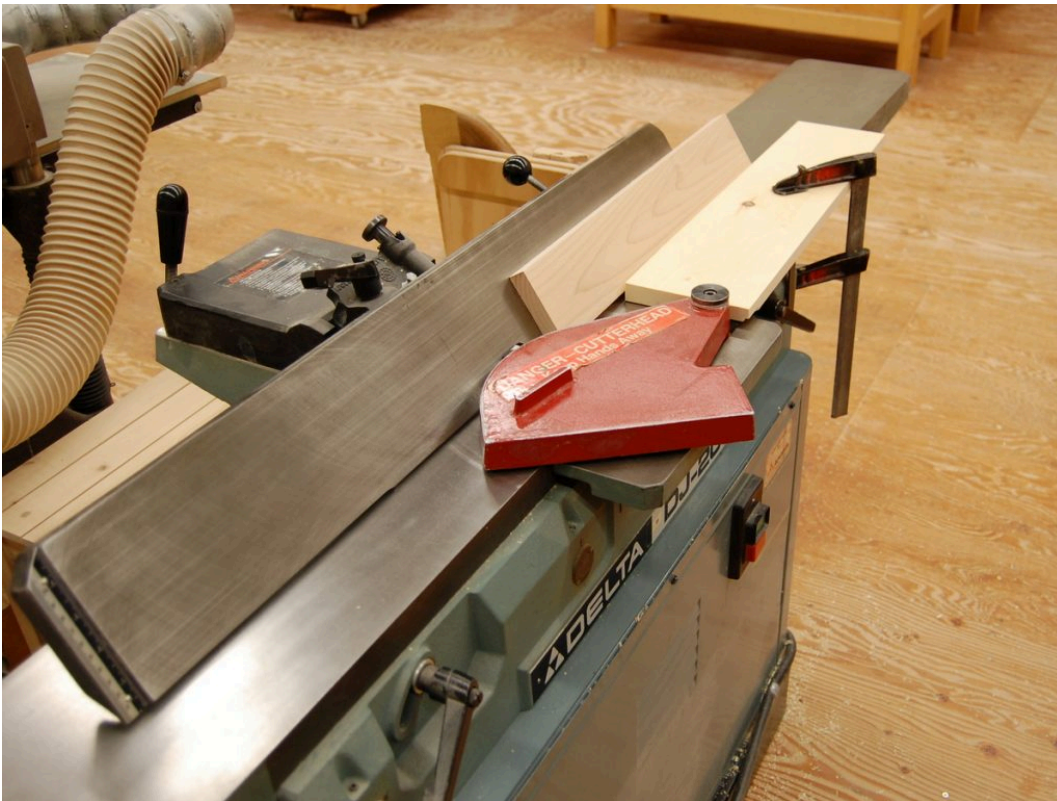

Beveling on the jointer with a support

Guard

The guard should be used at all times unless a specific operation, such as rabbeting, necessitates its removal. Guards should have a return spring to ensure they cover the entire cutterhead as soon as the workpiece clears the cutter. If the guard does not return quickly to cover the cutterhead, inspect the mechanism and adjust the spring as required.

Never use the jointer without the guard except in rare circumstances where the operation requires its removal.

Rabbeting ledge and arm

If the jointer has a rectangular recess in the table castings, the jointer can be used to cut rabbets. The spring loaded guard must first be removed. The knives must be set just past the rabbeting ledge to allow them to cut properly, and to allow the stock to remain tight to the fence throughout the cut. If they are set back from the rabbeting ledge, the stock will come away from the fence as it makes contact with the outfeed table. The ends of the knives should have a slight relief angle ground on them to allow for efficient cutting, and to prevent burning on the workpiece from friction.

The rabbeting arm is an extension that bolts to the left side of the infeed table. It supports wide work pieces while rabbeting the face of a board.



Rabbeting arm and ledge. The guard must be removed to cut rabbets.

Dust chute

The chips generated by the cutterhead are directed out of the machine by the dust chute. This chute is part of

the machine base, and usually terminates in a housing for dust collection. On small, hobbyist machines, there may not be dust collection in which case the debris piles up on the floor.

From time to time, the chute may become clogged with chips. You will know it is clogged if chips are coming back out of the cutterhead onto the infeed table as you are jointing. To clear the blockage, lock the machine out and confirm by pressing the start switch. Remove the dust collection port, and use your hand or a short stick to pull the chips out of the machine.

Push Block

Not a part of the jointer, but integral to its safe use is a push block. When face jointing, the distance from the knives to the face of the workpiece is too small to complete the cut while pushing by hand, and it would require passing your hands directly over the cutterhead. A push stick of the type used on the table saw can work, however more effective is a shop-made push block designed for the jointer. The block is long and flat, with a handle at the rear and knob at the front. The back bottom end has a thin strip of wood glued to the push block for hooking on the workpiece and moving it through the cut. Fasteners should not be used to attach the strip to the block as it may come into contact with the cutter when jointing thin stock and damage the knives. The block is long so that it may be used to safely hold down and guide thin and short work pieces without the operator being near the cutterhead.

Commercial foam-backed push blocks are also useful on the jointer. They can be used in conjunction with the push block described above for jointing longer stock.

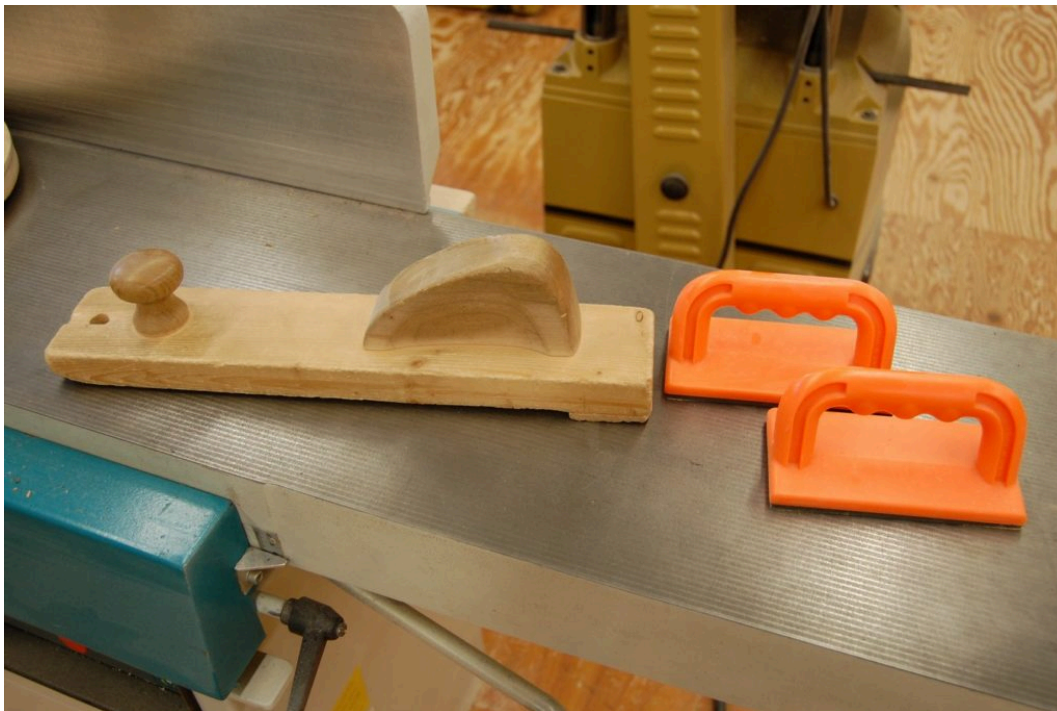

Jointer push blocks

Cutterhead

The cutterhead is a precision machined cylinder that is secured to the base casting and rotates via bearings. The

cutterhead can have between two and four straight knives, or many carbide cutters if the cutterhead is helical with inserts.

The size of the jointer is denoted by the length of the cutterhead. If the capacity of the machine allows it to face joint an 8" board, it is an eight inch jointer. Jointers are commonly available in sizes ranging from 6" to 20", with 8" and 12" being the most common.

The cutterhead is usually driven using a pulley and belt arrangement. Some older machines use a direct drive, where the motor is directly mounted to the shaft of the cutterhead.



*Helical cutterhead on a jointer. ***Guard removed for clarity*

Gibs

Most straight knives are held securely in the cutterhead with gibs. The gib is a metal bar that retains the knife in the cutterhead by applying pressure to the knife, forcing it against the slot in the cutterhead. The gibbs are removed to change the knives. Inspect and clean them of any residue before reinstalling them.

Gib screws

The gibs have threaded holes for gib screws. These machine screws have square heads that are slightly relieved on the top. As the screw is backed out of the gib, the head tightens against the machined slot in the cutterhead.

The slot in the cutterhead is narrower at the top (where the cutting edge of the knife protrudes) than at the bottom. This creates a dovetail shape that counteracts the centrifugal force acting on the knives as the head rotates.

Jack screws or springs

When the knives are changed, they must be set at exactly the same height. To assist in leveling the knives,

a small adjustment screw is located under the bottom edge of the knife at either end of the cutterhead. The screw may be turned in minute increments to get the knives perfectly adjusted.

Some jointers instead use a small spring in the same location. A block of wood set on the outfeed table keeps tension on the knives as the spring pushes them up. The gib screws may then be tightened.

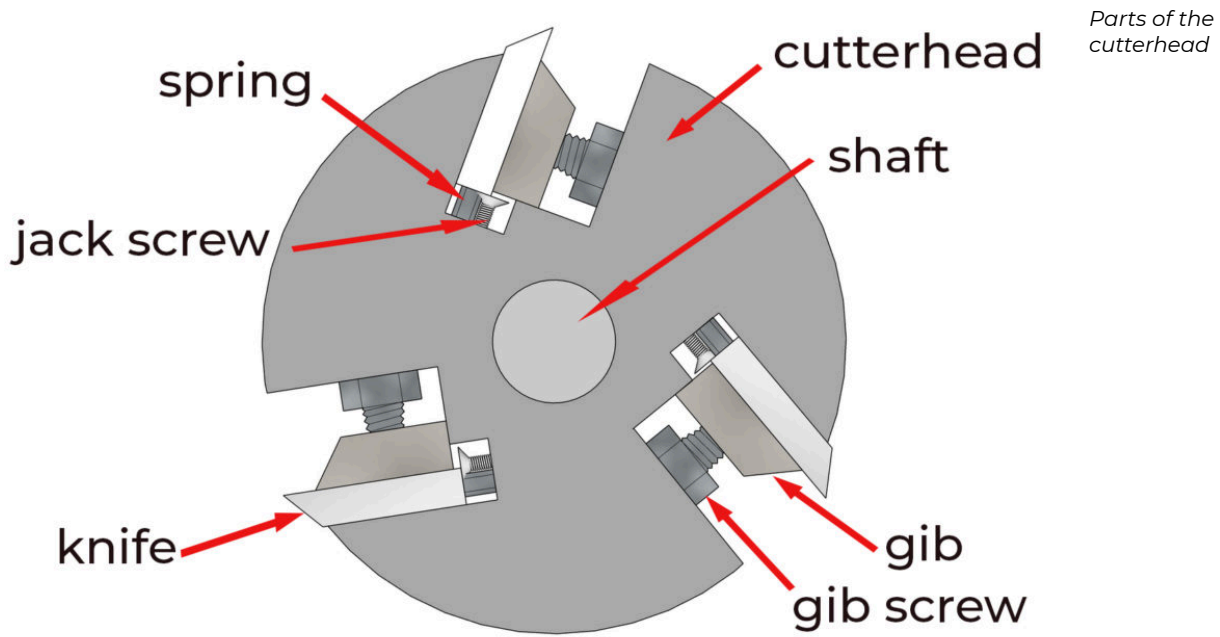

7. Tooling

Jointers are capable of producing an extremely smooth, clean cut if the tooling is kept sharp and free of nicks. If the machine seems to not be cutting properly, for example the cut seems to taper slightly, or it is difficult to get two pieces cleanly edge jointed for glue-up, it may be time to change the tooling. Tracks on the surface indicate nicks in the knives, however it is not always possible nor desirable to change knives for every nick. The fence can be positioned to avoid them, especially for narrow pieces. The knives can also be laterally offset from each other a small amount by loosening the gibs and repositioning them. This ensures that the nick on each knife is in a different spot, the other knives will then remove the track left by the damaged knife.

To keep the tooling sharp and in good condition for as long as possible, observe these guidelines:

- Never place material to be machined on the floor. It will pick up grit that will dull and damage the cutters.
- Never joint plywood or composites such as MDF, or painted or finished wood.
- Trim the raw ends of boards before jointing. They often have metal staples from inventory tags. The ends of logs are usually sealed at the mill to help prevent drying defects, the sealer is abrasive and will prematurely wear the cutter.
- Inspect the edges of every board for staples.

There are three types of tooling commonly used for jointers, including straight knives, disposable, and carbide insert.

Standard straight knives

Straight knives are commonly found on many jointers, both smaller models and larger industrial machines. In recent years, helical cutterheads have begun to replace straight knives on higher end tools.

The knives are often available in either high speed steel (HSS) or carbide tipped. HSS is a good choice for most work, and will produce an excellent surface quality. Carbide tipped knives cost quite a bit more in comparison, but will last longer before requiring sharpening. They are recommended for use in production settings, and for used with extremely hard and abrasive woods.

HSS knives can be honed in the shop with regular sharpening stones. Care must be taken to keep the entire edge of the knife perfectly straight, and to prevent rounding over of the cutting edge. To achieve this, the knives can be honed while in position in the cutterhead. A strong paper or plastic can be wrapped around part of the stone to prevent it from cutting into the outfeed table. The cutterhead is rotated until the knife edge is horizontal but a little higher at the toe. The outfeed table may have to be adjusted to accommodate this. The cutterhead is then wedged in position and the knife edges honed in turn. Once the bevel is honed, a slip stone may be used to remove the wire edge. If using water stones, ensure no excess moisture may wick between the knife and the cutterhead where corrosion could occur.

While HSS can be touched up with sharpening stones, both HSS and carbide knives are commonly sent out to a saw sharpening service be precision ground and sharpened. The knives must be balanced, or the same weight as each other, to reduce vibration. Both types can be sharpened many times before they must eventually be replaced.

Indexing, disposable

Because multiple knives must be installed in perfect alignment, manufacturers have developed knives that have a way of perfectly indexing with the cutterhead, negating the need for manual alignment. They are quick and easy to install. Some jointers and most portable planers use this type of knife. Many types of these knives are double sided and may be rotated once for a new, sharp edge. All of the indexing knives are disposable.

Different means of locating or indexing the knives have been developed. Some use a simple pin and hole method, where the knife has a hole that indexes to a pin on the cutterhead. Machine screws then secure the knife to the cutterhead. Another system is Tersa™ knives. These are double sided, and instead of being flat have an indent on the face that meets the cutterhead. A wedge is then inserted to keep the knife in place. Centrifugal force acts on the knife and wedge when the machine is running to lock everything in place, negating the need to use any fasteners.

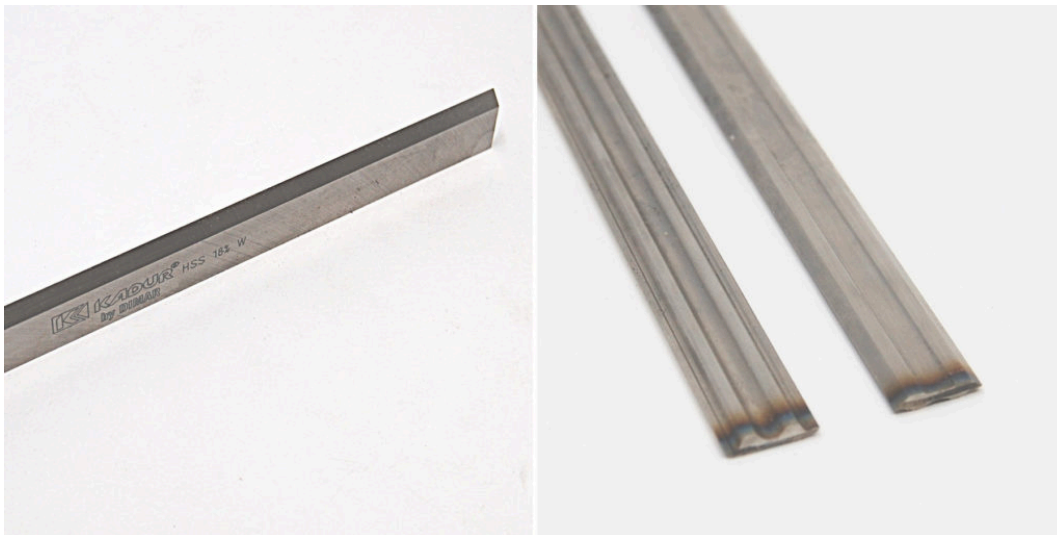

Jointer knives. Left: straight knife. Right: Tersa

Helical

A different type of cutterhead is now found on many jointers and planers. It uses a completely different system, replacing the typical three or four straight knives with a series of small carbide cutters. These cutters are arranged in a helical shape. This shape creates a shearing cutting action that slices the wood fibres more cleanly. Tooling that makes use of disposable carbide cutters that index to the tool body is known as insert tooling.



Helical cutterhead on a jointer

The carbide cutters are small squares that have a slightly radiused edge, which also contributes to the shearing action of the cutter. The cutters are disposable, however they may be rotated to use all four edges before needing to be replaced. Because the cutters are staggered in their rows, if a small rock or staple is run into the machine, usually only one or two cutters are damaged. When a cutter is damaged, it may be rotated for a fresh edge. In a straight knife cutterhead, the entire knife or set must be removed for sharpening if damage occurs. The cutters are secured to the cutterhead with machine screws. The shearing action of a helical cutterhead has a great advantage in the machining of figured woods as tear-out is greatly reduced. They also run quieter compared to straight knife cutterheads.



*Carbide inserts
(image courtesy
Byrd™ Tools)*

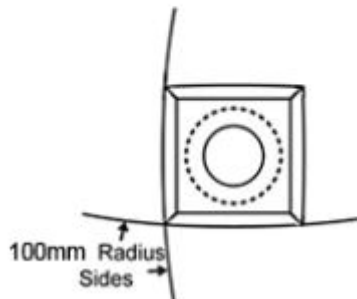

8. Use of the Jointer

Safety rules

As the cutterhead is exposed in use, the jointer must be used with caution and only by trained operators. Observe the following safety guidelines for the jointer.

- Never run your hands directly over the cutterhead while on the surface of a workpiece. Lift and place them, or use a push block.
- Do not place your hands within 150 mm or 6" of the cutterhead at any time.
- Do not place your hands within 150 mm or 6" of the leading edge of the board.
- Use a push block or stick at the end of the cut, especially when face jointing.
- Do not joint thin stock (less than 12 mm or 1/2").
- Do not joint material that is shorter than 300 mm or 12".
- Do not edge joint stock that is less than 20 mm / 3/4" wide, and use a push block designed for narrow stock.
- Only remove the spring loaded guard for rabbeting operations, and replace it immediately after use.
- Do not joint excessively knotty or defective stock. It could break apart while jointing.
- Do not joint end grain.
- Do not pull a workpiece back out of the machine, it can grab and kick back.
- Jointing a heavy cut increases the potential for kickback, always check the depth of cut before starting, and reduce the depth of cut for wider stock or dense hardwood.
- Feed the work at a rate that it does not reduce the speed of the cutterhead.
- Reset the depth of cut to 1 mm / 1/32" – 1/16" after using the jointer.
- Do not wear loose fitting clothing or jewelry. It can become tangled and pull you into the cutterhead.
- Follow all general machine safety rules.

Stock preparation

Material to be jointed should first be cut to rough length and rough width. Where rough stock is quite bowed or cupped, cutting it to the smallest size possible while still leaving a machining allowance will help to preserve thickness and width. Smaller pieces to be jointed should be left in multiple lengths to safely machine, and cut to size after jointing and planing. With all pieces to be jointed, ensure the ends have been trimmed free of defects such as splits or checks. This also ensures staples and paint are removed prior to machining. Do not joint plywood as the adhesive is very abrasive and excessively dulls the knives. Never place stock on the floor where it can pick up grit and small particles that will dull and damage the tooling.

Machine sequence

The jointer is the first machine used in bringing rough stock to an accurate piece, ready for joinery or further machining. Surfacing four sides, or S4S is a common step in almost all solid lumber machining. The steps should be completed in this order:

- Joint a face side.
- Joint an edge square to the face side.
- Plane to final thickness (using the thickness planer).
- Rip or plane to final width (using the table saw or thickness planer).

Grain orientation

When selecting the direction of feed, grain orientation must be checked to ensure the wood fibres are smoothly sheared and not lifted up. The grain on the board should be running from the top left to the bottom right when viewing the side of the board to be jointed. Another way to visualize this is the grain on the board should be running up away from the operator when viewing the side of the board to be jointed. If the grain reverses, slow the feed rate significantly when jointing against the grain. This helps to prevent tear out and usually achieves a better cut. The areas around knots always have reversing grain and the knots are harder end grain, reduce the feed rate to improve the quality of cut.

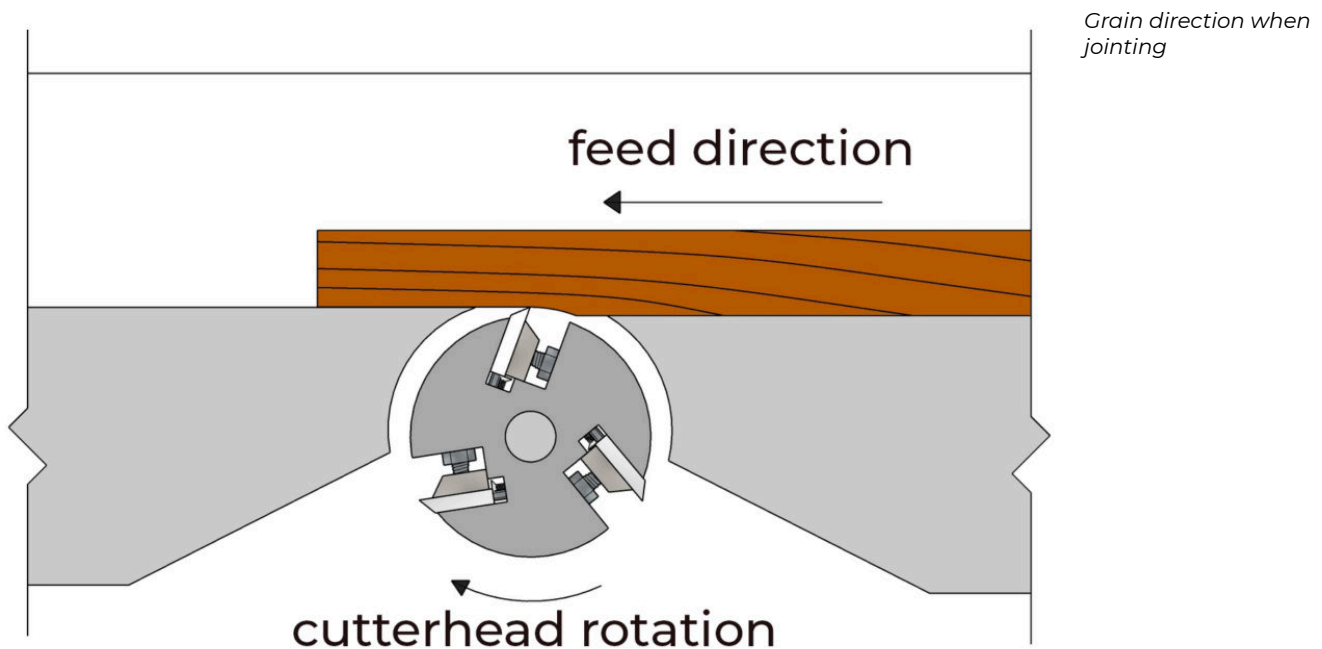

Depth of cut

The depth of cut is set by adjusting the height of the infeed table. It can be checked by locking out the machine and placing a straight edge on the outfeed table that overhangs the infeed table. The distance between the ruler and infeed table is the depth of cut.

Checking the depth of cut with a straight edge

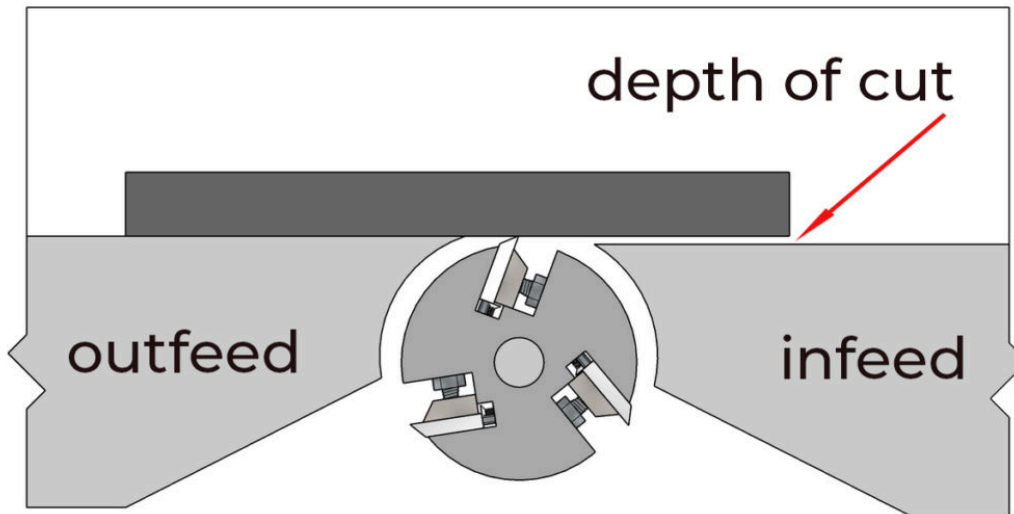

Safe operation of the jointer requires setting the correct depth of cut. Consider the total volume of material that is being removed in a single pass. Observe the following guidelines:

- Remove no more than 2 mm or 1/16" in a single pass. In rare cases, you can remove up to 3 mm or 1/8" when edge jointing narrow softwood.
- When face jointing wide stock, the depth of cut should be reduced. Or, the wider the cut, the less should be taken off in a single pass.
- Reducing the depth of cut will usually increase the quality of the cut.
- Reducing the depth of cut will usually result in less tear out.
- When jointing dense woods, the depth of cut should be reduced.

Feed rate

Unlike a hand plane, the jointer cuts with a rotating motion. While a quick glance may show the jointed surface to be flat, upon closer inspection it is clear it is made up of many small curved surfaces made by the rotation of the cutter while the stock is moving. These peaks and valleys are known as mill marks or machine marks, and show up as striations across the surface. If the stock is fed quickly, the mill marks left are larger. When several passes will be required to surface a workpiece, it is acceptable to use a faster feed rate on the initial passes to quickly remove material, then a slow feed rate on the last pass. The slower rate on the last pass will produce a much higher quality of cut.

Having a high quality of cut is particularly important when edge jointing boards that will be laminated. Most

adhesives require wood to wood contact, the large peaks and valleys left by a fast pass over the jointer will produce unacceptable results and could result in joint failure.

Running stock too quickly over the jointer is dangerous as the potential for kickback and loss of control is increased. Always feed stock in a controlled manner.

How the jointer works

When passing material over a jointer the cutterhead removes points of the wood that are high. The just-machined wood references on the outfeed table and is kept in the correct plane as the remainder of the board is jointed. Passes are repeated until all of the surface has been surfaced.

For the jointer to work properly, it is critical that the height of the outfeed table is set exactly to the height of the knives at the highest point in their rotation, minus a tiny amount to account for the peaks (mill marks) that are left on the surface by the knives. It is these peaks that reference on the outfeed table. A straightedge placed on the outfeed table will just touch the edge of a knife when it is rotated to top dead centre. Problems arise when the outfeed table is either too high or too low in relation to the knives at their greatest depth of cut.

Outfeed table too high

If the outfeed table is set too high, the workpiece gradually rides up on the outfeed table as the cut progresses. A taper is cut instead of a consistent amount of material being removed from the surface being jointed. If the jointer consistently stops cutting toward the end of the workpiece, the outfeed table is too high.

If the jointer is to be used for trimming and sizing, it is imperative that the outfeed table be in perfect alignment to prevent tapering cuts.

The outfeed table set too high causes a taper

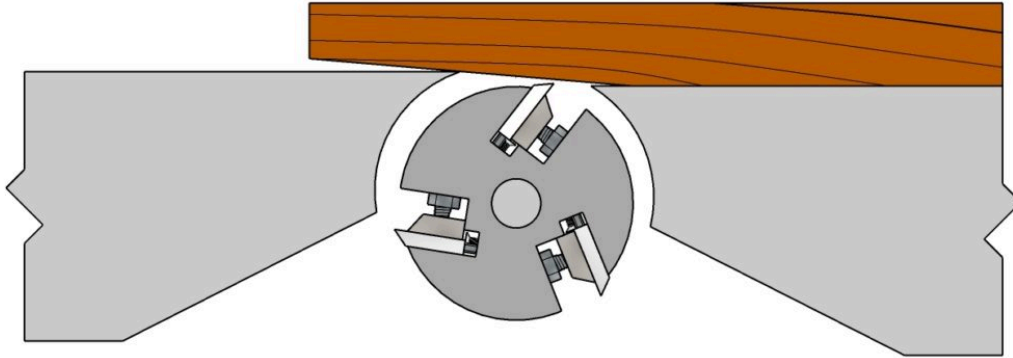

Outfeed table too low

If the outfeed table is too low, at the end of the cut as the workpiece clears the infeed table, it drops down on to the cutter head and snipes the end of the board. A severe snipe can cause a kickback as the wood is suddenly dropped into the cutterhead. A small or moderate snipe is an issue when edge jointing boards for lamination, as wood to wood contact is lost at the ends of the panel.

at the start of cut, the piece is not supported by the outfeed table

Snipe is caused by a low outfeed table

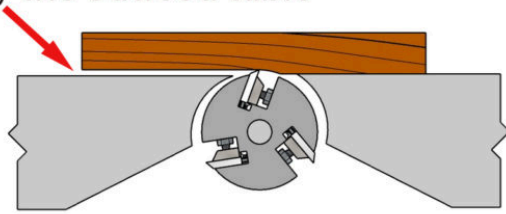

at the end of cut, the trailing end drops down into cutterhead as it clears the infeed table, causing snipe

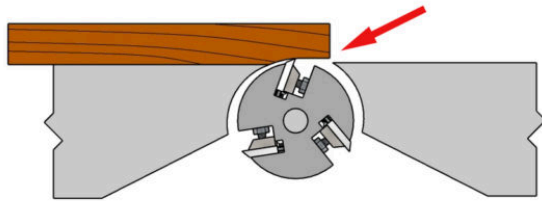

snipe at the end of the piece

More than almost any other woodworking machine, the jointer requires both precise set-up of the cutterhead and tables as well as a skilled operator who understands how the machine works to achieve desirable results.

Procedure for face jointing

Follow these steps for safe and accurate face-side jointing:

- Place the cupped or concave side face down on the infeed table. This provides the most stability as it is jointed. It will usually be the sapwood side of the board.
- Determine grain direction, and orient the board so knives will be cutting with the grain.
- Using light pressure, advance the board into the cutterhead. Once the board is supported by the outfeed table, keep moderate pressure on the outfeed table just behind the cutterhead. Maintain this pressure throughout the cut.
- Never pass your hands directly over the cutterhead while face jointing. Even though the cutterhead is covered by the work piece, potential for kickback or the workpiece shattering exists. Lift and place your hands over the cutterhead.
- Do not push down excessively on the infeed side of the cut. The workpiece will deflect, then spring back when the cut is complete. The face will look and feel smooth, but will not be flat.

- Use a push block hooked on the end of the workpiece to safely finish the cut.
- For shorter or thin boards, use a push block throughout the entire cut for safety.

For boards that have twist, locate the corners that make contact with the table. Focus pressure on these high points for the first pass or two until the board makes contact with the table without rocking. Use a push block to keep your hands away from the cutterhead at all times.

The number of passes required to surface a piece depends on how out of flat it is to start with, and the depth of cut. Every piece is different; a relatively flat piece can be surfaced in a single pass, while larger pieces with more bow, cup or twist can take several passes. It is best to take several light passes than one heavy one for safety and quality of cut.

Procedure for edge jointing

Follow these steps for safe and accurate edge jointing:

- Choose the edge with the least amount of defect (such as wane or grain run-out) to joint.
- If possible, joint the edge that is concave. It will be stable on the table and not rock.
- Place the jointed face against the fence.
- Place the thumb of your left hand on the top edge of the piece, and use your fingers to keep the face tight against the fence. Your thumb prevents your hand from slipping off the face of the board.
- Use your right hand on the end of the piece to provide forward motion, and keep the face against the fence.
- If the stock is narrow, use push sticks to guide it over the cutterhead.
- Observe the same guideline for maintaining pressure as in face jointing.

9. Common Operations

Face and Edge Jointing

The jointer is used for preparing solid wood, making faces flat and true. As solid wood dries from the green (wet) state, it shrinks and changes dimension unequally in the radial and tangential plane. It may have inherent stresses that are released as it is cut to rough size. Face jointing the stock will remove bow, cup and twist from the boards. Edge jointing will straighten the stock, removing crook and kink. Edge jointing will also machine a known angle between the face and edge, for square stock at 90° but also at any angle between 45° and 90° by adjusting the angle of the fence. The face of the board should be jointed first, then the edge can be squared to the face.

Procedure for face jointing

- Determine which face (if any) is concave, it should be placed down on the table. This will be the most stable arrangement, allowing for the piece to be jointed without shifting or rocking on the tables.
- Begin to move the piece into the cutterhead with a hand over hand motion, remembering to lift your hand over the cutterhead and not run it directly over while on the workpiece.
- Apply light pressure on the piece at the start of the cut, enough to keep it in contact with the table. Avoid excessive pressure as this will cause the piece to deflect and spring back after the cut is complete.
- As soon as a sufficient amount of stock is on the outfeed table, transfer the downward pressure to just behind the cutterhead on the outfeed side of the cut. This ensures the part of the stock that was just-cut references the outfeed table. The result will be a flattening of the stock.
- It may take multiple passes to flatten the entire face. The number of passes is determined by the depth of cut per pass, and the amount of defect in the stock.
- Continue jointing until the entire face has been surfaced. Often, listening to the machine will tell you when you have made a full pass.
- With boards with excessive defect such as twist, finesse is required to achieve satisfactory results. The twisted board will have two opposing corners contacting the table, these should be passed over the cutterhead to remove the twist. The piece must be balanced on the two corners while jointing, without rocking.
- You may place paper or veneer shims under the corner not contacting the table at the trailing end of the board to help stabilize it. They will come loose as the end passes over the cutterhead, but do not pose a kickback hazard. Use only thin commercial veneer or paper for this purpose.

Procedure for edge jointing

In most cases, the concave edge is placed down on the machine table for stability. However, in some cases it may be desirable to have the convex edge contacting the table, such as when selecting for grain direction or to remove defects.

- Ensure the fence is set to the desired angle. Use an engineer's square for 90° or a sliding T bevel or digital inclinometer for angles.

- Place the edge to be jointed on the machine table, and the jointed face against the fence. It is important the jointed face is placed against the fence, not facing away.
- Apply pressure on the face of the workpiece to keep it tight to the fence as you begin the cut, at the same time as applying downward pressure to keep the piece tight to the table. The reference surface for edge jointing is the fence, not the bed of the jointer.
- Use your hands or a push block to keep the piece in contact with the fence as you pass it into the cutterhead. Remember to lift your hands over the cutterhead as you progress through the cut, never place your hands directly over the cutterhead.
- As soon as a sufficient amount of stock is on the outfeed table, transfer the downward pressure to just behind the cutterhead on the outfeed side of the cut, while keeping the face in contact with the fence.
- Continue jointing until the edge has been surfaced.
- It may take multiple passes to joint the entire edge, as in face jointing.

Preparing edge joints for laminated panels

One of the most common operations performed on the jointer, other than surfacing faces and squaring edges, is preparing boards for an edge-glue lamination. There is a particular machining sequence to follow that will produce tight, well-fitting joints.

The pieces to be laminated should be surfaced two sides (S2S) to final thickness, plus a small machining allowance if they are to be planed or thickness sanded after glue up. The pieces should have reasonably straight edges and be ripped to rough width, with enough of a machining allowance added to joint the edges as well as trim the laminated panel to final size. Allow a minimum of 4 mm additional width per piece.

Set the pieces on the bench top, and arrange them for grain and appearance. Mark the face with an inverted 'V' across the width of the panel, as in the image below. This identifies the location of each piece in the panel so they may be easily put back in the correct order.

Marking up a panel for edge jointing

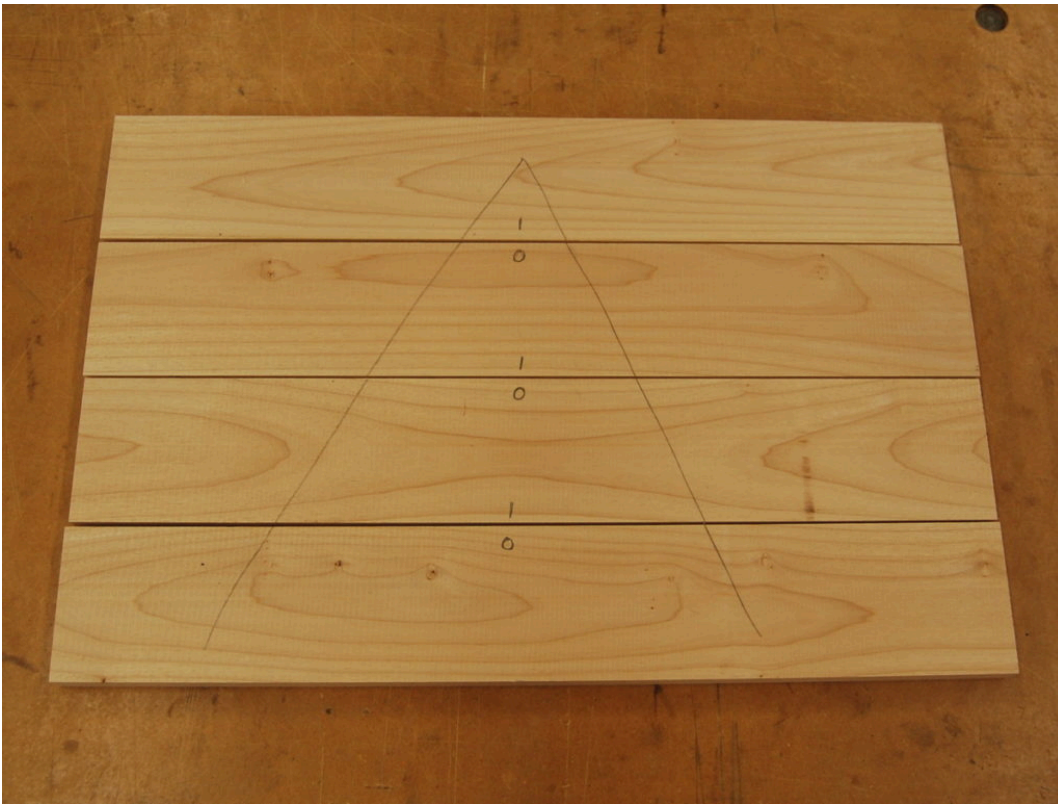

At each joint, mark the faces of pieces with an 'I' and an 'O'. These letters stand for 'in' and 'out'. Pieces with an 'I' will be jointed with that face against the fence, while piece with an 'O' will be jointed with that side facing out from the fence. This alternating of face in, face out ensures the panel will be perfectly flat as any amount the fence may be out of square is balanced by the next piece being flipped over. If the fence is out of square at all, and the faces are all run in the same orientation, the panel will take on a cambered (cupped) shape.

Edge jointing for flat panels



edge is not square



flip alternating faces, and the mating edges form a supplementary angle (straight line)

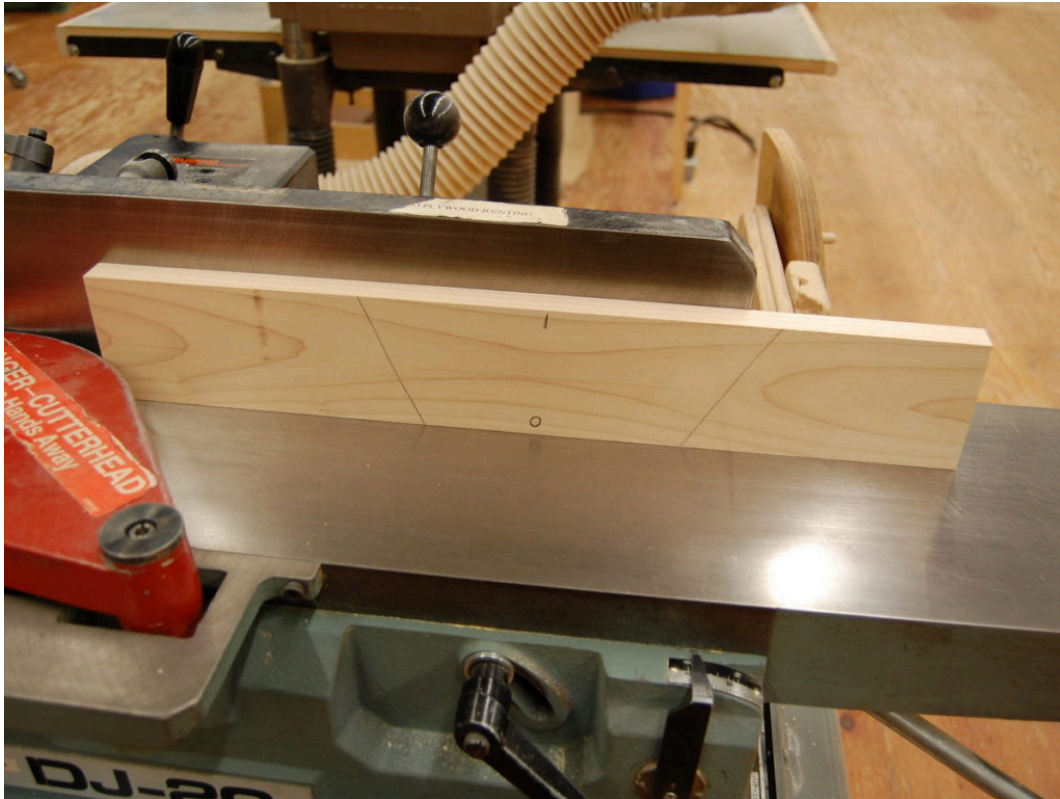

Jointing edges, face in and face out

When jointing each piece, apply light pressure at the start of the cut, moderate to heavy pressure through the middle of the cut, and light pressure at the end of the cut. This technique helps to create a jointed edge with a slight concavity along its length which is desirable in creating a tight, 'sprung' joint. In some cases, the edge of the piece is convex, which can be difficult to joint straight or slightly concave. Try taking the high portion out of the centre by jointing a small amount out of the middle of the piece.

To perform this operation, have the end of the workpiece resting on the infeed table while holding the remainder above the cutterhead. You will need to pull the guard out of the way to begin the cut. Starting about a quarter of the way in from the front end of the piece, carefully lower the piece on to the cutterhead and joint the middle until a quarter of the distance from the end. Hold the piece firmly on the table, turn off the jointer and allow it to come to a complete stop. Increase the depth of cut slightly, and re-joint using the technique for a sprung joint. Removing material in the centre portion before taking a final pass usually results in a sprung joint.

Extreme caution must be exercised as you lower the workpiece onto the cutterhead!

When preparing surfaces for glue joints, ensure the knives are sharp. Dull knives create a burnishing effect as the knives strike the surface (as opposed to cut) and decrease joint strength. Ensure pieces are run slowly on the last pass to reduce the scalloping effect of the circular cutterhead, this ensures better wood to wood contact which most adhesives require.

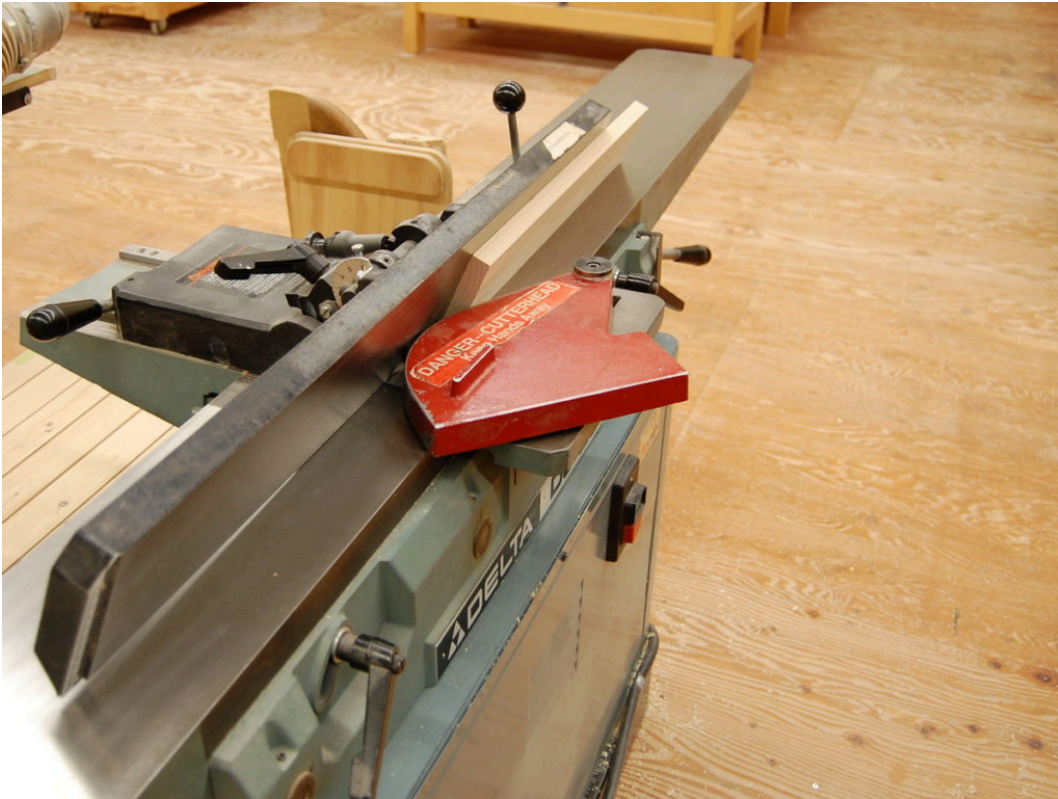

Beveling on the jointer

Joint the piece using the technique for edge jointing. The first passes will remove only a small amount of material. Make repeated passes until the bevel is cut across the entire edge of the piece. Alternately, chamfers can be cut by setting the depth of cut and running the piece a set number of times over the machine. Always set up using a test piece to ensure the correct size.

Octagons can be made by chamfering a squared block on the jointer with the fence set at 45°. Use a support block clamped to the table as the bearing surface decreases in size as the chamfers are cut and the piece may become unstable.

Always use a push block for narrow and thin pieces.

Rabbeting

Unless the piece is narrow, as in an edge rabbet, the guard will need to be removed from the infeed table. The height of the infeed table sets the depth of cut. The width of the rabbet is determined by the distance from the fence to the edge of the knives. To cut a rabbet, keep the workpiece tight to the fence. Lower the infeed table with every pass over the jointer until the desired depth of cut is reached. Feather boards may be clamped to the fence to aid in keeping the work tight to the tables. If multiple pieces are to be rabbeted, each piece should be run before adjusting the depth of cut to ensure accuracy and efficiency.

In softwood for door and window jambs, some rabbets may be run in a single pass with a heavier depth of cut than would be acceptable for face jointing, as the width of cut is generally small. Lower the feed rate to reduce the danger of kickback. Not all rabbets can be run in a single pass.

Be extra cautious when jointing with the guard removed. Always replace the guard immediately.



Jointing an edge rabbet

When face rabbeting, a featherboard can be clamped to the fence to increase accuracy and safety. Always use heavy duty clamps and ensure they are securely attached with no danger of slippage.



*Jointing a face rabbet
with a featherboard*

Jointing a taper

Tapered cuts can be made on the jointer by starting the cut part way down the length of the workpiece. This is accomplished by slowly lowering the piece onto the outfeed table before running the remainder of the workpiece over the cutterhead.

Extreme caution must be exercised as you lower the workpiece onto the cutterhead!

- Lock out the machine.
- Set the depth of cut. Slight tapers can be cut in a single pass, while heavy tapers will require multiple passes.
- Mark the start of the taper on the workpiece, and position it so it is located where the knives begin cutting.
- Clamp the stop block to the fence or infeed table at the end of the workpiece.
- Place the end of the workpiece against the stop block.
- Hold the remainder of the workpiece above the cutterhead. With the machine running, carefully move the guard out of the way just enough to allow the workpiece to make contact with the cutterhead.
- Carefully lower the workpiece down on to the outfeed table. Use extreme caution as your hands will be lowering the stock directly in front of the cutterhead
- Use a hold down or push block to move the workpiece safely over the cutterhead to complete the cut.
- Repeat the tapering cut on multiple faces, and in multiple passes if required.

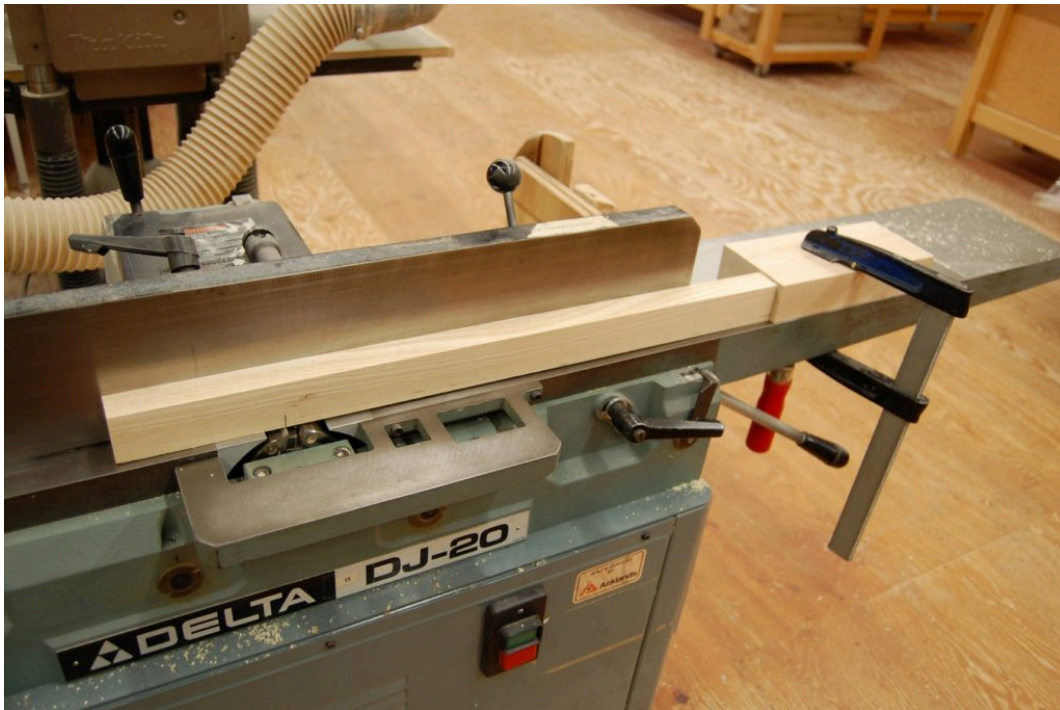

*Jointing a taper.
Guard removed for
clarity.*

Recessing

A similar technique to tapering on the jointer can be used to cut a shallow recess in a workpiece. Mark the start and stop point of the relief. With the machine locked out, position the layout mark with the start of the cut. Set a stop block on the jointer fence at the end of the workpiece. With the jointer running and the end of the workpiece against the stop block, carefully lower the piece onto the cutter. Move the piece forward just past the halfway point. Hold the piece firmly in place on the table and turn off the machine. When it comes to a complete stop, remove the workpiece, turn it around and repeat the cut on the other end.

This technique will produce a recess with radiused ends and the middle slightly tapering toward the centre. The taper can be left as is or quickly straightened with hand tools. The center portion cut can be made straight on the jointer if the outfeed table is also lowered. However, the outfeed table must then be recalibrated. A better option if a perfectly straight recess is required is to use the router table and a straight bit.

10. Set up and Maintenance

The jointer requires sharp tooling and precision set-up to perform the work it is designed to do. Perhaps more than any other woodworking machine, maintaining and adjusting the jointer is an art that requires a thorough understanding of the mechanics involved and the skill to dial in the correct adjustments. Every jointer is a little different, it takes experience to know a particular machine and how to set it up to perform well.

Adjusting the outfeed table

Occasionally, the jointer will not produce straight, flat faces and edges. Instead, it cuts a taper, or snipes the end of the piece. These can easily be corrected by adjusting the outfeed table height with respect to the knives.

- Lock out the power to the machine.
- Using a quality straight edge such as a steel ruler placed on edge on the outfeed table, observe the position of the table in relation to the cutterhead. Rotating the cutterhead by hand will reveal if the knives are not touching the ruler (table too high), or lifting the ruler off the table (table too low). This observation will help you determine how far the table needs to be adjusted.
- Unlock the outfeed table and adjust. Use the steel ruler on edge to check the location.
- Lock the table, power up the machine and make a few test cuts.
- Keep making adjustments until the jointer is cutting properly.

Changing straight knives

Changing knives in the jointer can be an art. Different methods have been developed for getting the knives at exactly the correct height which is necessary for the machine to perform properly. It is often necessary to readjust one or all the knives multiple times to get them set properly. The method used will also depend on the exact configuration of the jointer as they have different means of adjusting the height of the knife.

Follow these general steps to change straight knives. Also refer to the machine manual if it is available.

To remove the knives:

- Lock out the machine.
- Unlock the fence and move it to the far right position on the machine bed to allow full access to the cutterhead.
- Loosen the gib screws for one knife. Carefully remove the knife out of the cutterhead, and remove the gib.
- Be aware that when rotating the cutterhead without the knife and gib installed, the jack screws and/or springs may be loose and can fall into the base of the jointer. Change one knife at a time unless you are sure there are no loose parts.
- Clean any pitch or sawdust from the surfaces of the cutterhead and the gib using mineral spirits or strong citrus cleaner. Check the gib for any sharp edges or burrs, lightly file if necessary to remove them.

To reinstall the knives:

- Use mineral spirits to clean the knives of any oil or contaminants. Hone the back of the knives to be installed with a flat, fine water stone to remove any burrs and dry thoroughly.

- Position the gib in the cutterhead, and slide the knife into place. Turn the gib screws until there is no play between the knife, gib, and cutterhead. The knife should still be able to move.
- If the jointer uses a spring under the knife, lay a flat, heavy block of wood on the outfeed table. Press the block into the knife while it is at the top dead centre of its rotation. This positions the knife at the correct height. Tighten the gib screws just enough to keep the knife in place when the wooden block is removed. It is important to tighten the gib screws in sequence a little at a time to help prevent the knife from shifting. After the initial tightening of the screws, check the height of the knives with the block again to see if they have shifted. Adjust if necessary, and tighten all screws one last time.
- If the jointer uses jack screws, use a narrow block of wood or a steel ruler as a gauge. Turn the jack screw until the edge of the knife at top dead centre of its rotation makes contact with the block or ruler. Do this on either end of the knife where the jack screws are located until the knife touches equally. It may be necessary to use a wooden block to tap the knife back down if it has been raised too far. Tighten the gib screws just enough to keep the knife in place. Check alignment and adjust if necessary, and tighten all screws one last time.
- Check the height of the knife. Place a thick ruler on edge or block of hardwood on the far right side outfeed table so that it hangs just past the knife. If using a wooden block, make a reference pencil mark on it at the edge of the outfeed table. If using a ruler, place the ruler a set distance past the outfeed table.
- Slowly and gently, rotate the cutterhead by hand. The knife should pick up the block or ruler, move it forward and set it down. If it does not pick up, lower the outfeed table slightly until it does. Note the distance it moved. If using a wooden block, make another mark at the edge of the outfeed table. The distance the block or ruler moves should be the same left to right, and for all the knives. Adjust as necessary until the block or ruler travels the same distance.
- Install all the knives using the steps above.
- The distance the block moves is not initially important for setting the knives, it only ensures they are all the same height. Once this step is complete, the outfeed table can be calibrated to the knives. It should be adjusted so that the ruler or block moves about 3 mm or $\frac{1}{8}$ ", which will mean the knives are about 0.003" above the outfeed table. This distance accounts for the peaks left by the circular cutting motion of the knives.
- Use a piece of scrap wood to test the knives and the height of the outfeed table. If required, adjust the outfeed table until the jointer is neither sniping nor cutting a taper. Check by making passes on both the left and right side of the table.

It is important to tighten the gib screws in sequence a little at a time. When tightening, snug up the end bolts first, then the centre bolts, then the intermediate bolts while alternating left and right sides. Once they are snug, tighten them in two or three steps in the same order. This method helps keep the blade from shifting during tightening.

Magnetic knife setting jigs are available to assist in set up. They sometimes come with the machine, or can be purchased as an aftermarket accessory. They use magnets to hold the jig securely to the table, and to hold the knives at the correct height. Once the jig is in place on the table, the magnets hold the knives while the gib screws are tightened. If using a knife setting jig, it is still necessary to check the knives for alignment as the jig does not guarantee the knives are perfectly set.

Changing carbide insert cutters

Changing insert cutters is simple, with no need to adjust the individual cutters to height or adjust the outfeed table. Using the correct tool, such as a Torx™ drive, the inserts are unbolted from the cutterhead. If damage has occurred, a single cutter can be rotated to a fresh cutting edge. If the entire head is to be changed, the cutters are all rotated in the same direction to keep track of which edges are fresh and which are used. A paint pen can be used to mark the cutters which are used or new, and the direction of rotation for the next change.

When the cutters are tightened, care must be taken to exert the correct torque on the cutters. If they are under-tightened they can potentially vibrate loose, while over-tightening can shatter the brittle carbide. A **torque wrench** should be always be used to tighten the machine screws.

Cleaning and lubricating the tables

The tables and fence on a jointer should be kept clean and free of pitch and contaminants. Follow the [procedure](#) for cleaning and waxing the table saw.

In addition, the pivot points on the fence should be kept lubricated. Use a few drops of light machine oil to keep the fence moving easily. The mating surfaces of the fence and table where the fence slides should also be kept clean and lubricated. White lithium grease works well for this and lasts longer than paste wax.

PART III

THICKNESS PLANER

Like the jointer, the thickness planer is used in the initial stages of machining solid wood. It, along with the table saw and jointer are used to process rough lumber flat, straight, and square. The planer is used to machine wood parallel and to consistent thickness. It should be used after the stock has had a reference surface flattened on the jointer. Single surface planers remove material on one face at a time. Stock is fed into the planer with the jointed surface face down on the table. The cutterhead is parallel to, and positioned above the table and cuts the opposite face. In this way, material that is fed into the planer exits the machine with two parallel faces.

It is important to note that the thickness planer does not flatten the stock, it simply makes two faces parallel and a consistent thickness. Material fed into the planer that is bowed or twisted will retain this defect, although the face will appear smooth. The jointer and planer are designed to work together to accurately machine solid wood flat, straight, and square.

Single surface planers are common in most woodworking shops. In industrial production, double surface planers remove material from the top and bottom of the stock in one pass, and 4 or 5 head moulders process rough stock in a single process that eliminates the need for separate ripping, jointing, and planing processes.

The size of a planer is indicated by the length of its cutterhead. For example, a 15" planer has a maximum width of cut of 15". The other capacity in a planer is the maximum cutting thickness.

Types of single surface planers

There are three main types. Small, portable planers have **universal motors** that turn at high speeds and produce a fine finished surface. They commonly have [indexing](#), disposable knives, and take only small amounts of material in a single pass. They usually have a 12"-13" cutterhead.



Portable planer

Stationary planers have a larger cutting capacity, from 12" to 20", and can handle larger, heavier stock. They can remove a greater amount of material in a single pass, and may have variable speed feed control. Feed speed control is the ability to change the speed that the stock is fed through the machine. It is often specified in feet per minute.



Stationary planer

Industrial planers have cutterheads from 20" and up. They can take very heavy passes and have a greater range of speed feed control.



Industrial planer

11. Parts of the Planer

This video is specific to the model at BCIT, but the parts, operation, and safety rules are the same. Note the minimum length that can be safely machined depends on the model of planer.



One or more interactive elements has been excluded from this version of the text. You can view them online here: <https://pressbooks.bccampus.ca/woodworkingmachinery/?p=148#oembed-1>

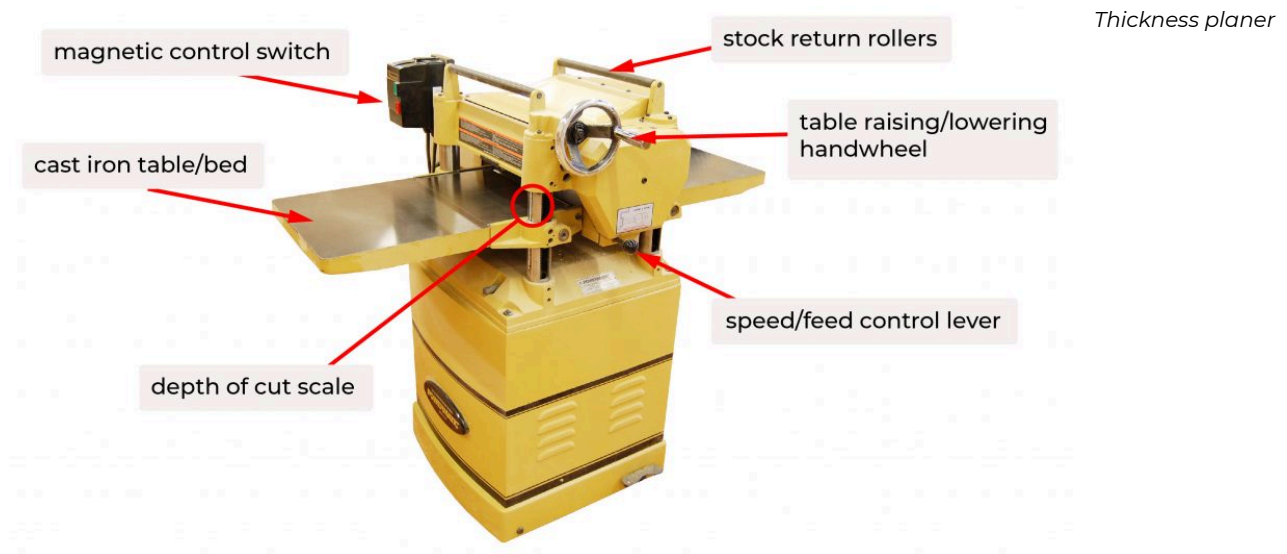

The planer is more complex than the jointer in terms of parts, but easier to use once the mechanics are understood. Unlike the jointer and table saw, the planer has a mechanism that self feeds the work through the machine, increasing its complexity.

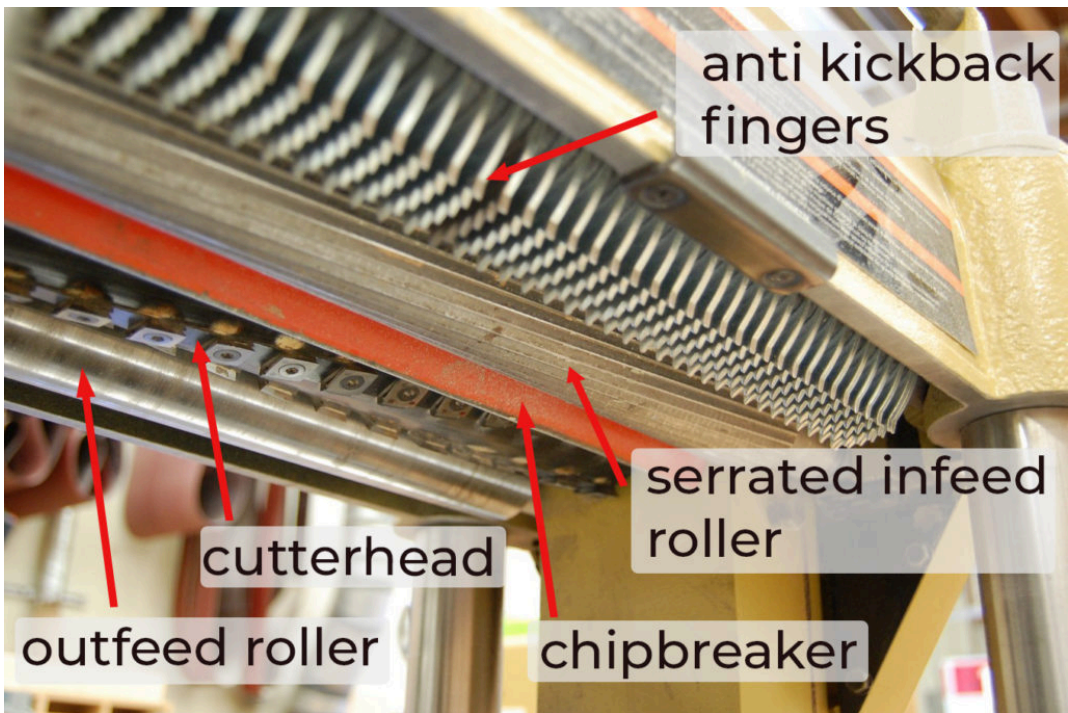

Inside the planer head

Planer components

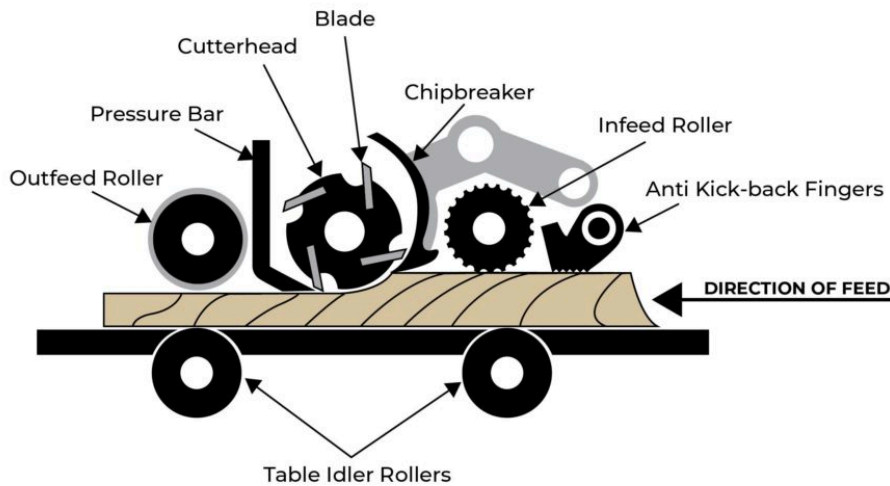

Cutterhead

The thickness planer cutterhead and tooling is nearly identical in design to the [jointer cutterhead](#). It may have straight knives, disposable, or carbide insert tooling. The size of the planer is denoted by the length of the cutterhead. Another measure of planer capacity is the maximum height above the table the cutterhead can travel. This determines the maximum thickness of stock that can be fed through the machine.

Infeed rollers

The infeed rollers are powered to grip and push the material into the machine while keeping it tight to the table. They are spring loaded to allow the material to pass underneath. The tension on the rollers is adjustable.

On some machines, the feed rate can be adjusted by changing the RPM of the rollers. There are three types of infeed rollers, all perform differently.

Smooth

Smooth rollers with a neoprene covering are found on small portable planers and some light industrial planers. Because they are smooth, they grip the wood without leaving any marks or defects in the surface. Planers with smooth infeed rollers excel at taking light finishing cuts. The infeed roller is a single cylinder that is parallel to the machine table, which can have some disadvantages when feeding multiple parts of different thicknesses at the same time. The one piece roller tends to feed the thicker stock while thinner pieces stall in the machine from lack of down and feed pressure.

Serrated

Serrated infeed rollers are commonly found on larger planers. They have grooves or serrations machined into the steel cylinder to grip and feed the material through the cutterhead. Machines with serrated infeed rollers are capable of taking heavier passes, and at higher feed rates. However, the serrations will leave marks on the surface if the depth of cut is less than the bite of the serrations. If the infeed roller is leaving serrations at a moderate depth of cut, the tension may be too high and can be adjusted.

Segmented

On larger industrial planers, the serrated infeed roller is broken up into smaller sections, or segments. Each segment is spring loaded and can move up and down independently. This allows material of different thicknesses to be planed at the same time without the tendency of the thinner pieces to become stalled in the machine. It is more efficient as stock of varying thicknesses can be fed at the same time.

Outfeed rollers

The outfeed rollers are also powered to help feed the stock and exit it from the planer while keeping it tight to the machine table. Outfeed rollers are always a single cylinder as the material that exits the machine is a consistent thickness, and there is no need for segmentation. The rollers are smooth to prevent marring the finished surface. Planers with neoprene infeed rollers will also have neoprene outfeed rollers; planers with serrated infeed rollers will have smooth steel outfeed rollers.

Pressure bar

The spring loaded pressure bar is located just past the cutterhead as close as is safely possible on the outfeed

side. It applies pressure on the wood to prevent it from rising up and being overcut by the knives. This tendency to overcut or snipe occurs as the end of the board is no longer held down by the infeed roller.

Chip breaker

The chip breaker in a planer functions much the same way a chip breaker in a hand plane does. It presses on the surface of the material just ahead of the cut, forcing the wood fibers being cut to break off in small pieces instead of long slivers, preventing tear out. Small portable planers do not have chip breakers, they rely on high cutterhead speed, low feed speed and small depth of cut to limit tear-out.

Anti-kickback fingers

Anti-kickback fingers are located just before the stock engages the infeed roller. They move freely up and out of the way of the workpiece in the forward direction, but prevent the stock from being backed out of the planer, preventing kickback. Occasionally, a workpiece gets jammed in the planer and it is necessary to lower the table to clear the fingers and remove the piece.

Table bed

The table bed is a single surface that is perfectly flat. On small portable planers, it is usually made of sheet metal which lessens the weight of the machine, on stationary planers the table bed is cast iron. In portable planers, the table is fixed while the cutterhead moves to adjust the depth of cut, in stationary planers the table moves while the cutterhead is fixed. The table bed should be kept clean and waxed to reduce friction and allow stock to move easily. Some planers have an extension off the main tables to increase the surface area. It may be a frame with rollers or solid cast iron. Caution must be exercised when working on a planer with extension table rollers as there is a greater possibility of catching clothing or hands in the space between the rollers and the stock.

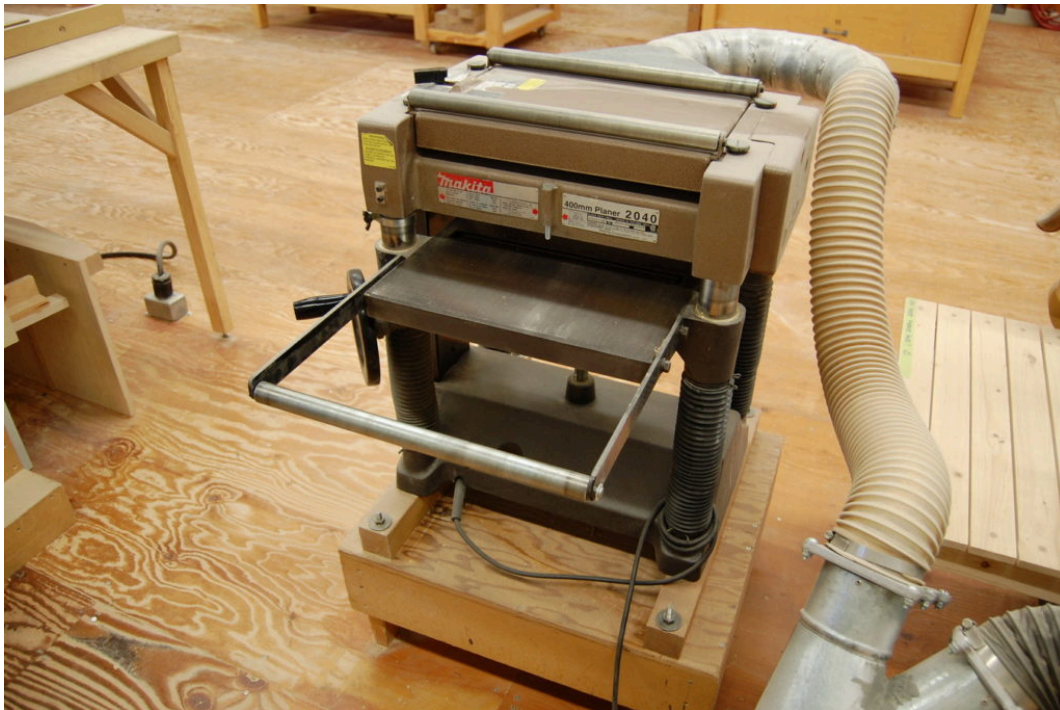

Open roller table extension

Table or idler rollers

To allow the stock to travel through the planer while still being held firmly down to the table, the table has two rollers located directly under the infeed and outfeed rollers. They are set just higher than the table surface to reduce friction and drag. They should be kept clean and free of pitch and residue.

Idler rollers can be a cause of sniping if they are set too high above the table. If sniping occurs, try lowering the rollers as far as possible while still keeping them in contact with the workpiece.

Height adjustment

Many stationary planers use a handwheel to engage a lead screw that adjusts the depth of cut. Small portable planers may use a knob or hand crank. Large industrial planers often have a powered height adjustment. The height adjustment should always be in the forward advancing position (moving from thick to thin) on the final pass to prevent backlash in the screw mechanism resulting in table movement. The depth of cut should be locked on the final pass.

Depth of cut gauge

On many planers, a scale and pointer is used to indicate depth of cut. It should be used as a guide only. The most reliable means of confirming is by measuring a piece that has passed through the planer. When changing the knives in a straight knife cutterhead, always recalibrate the gauge.

Some planers have a type of gauge that reads directly off the surface of the workpiece to show the depth of cut. Others have a limiter on the infeed side that will not allow material that is too thick to be planed.

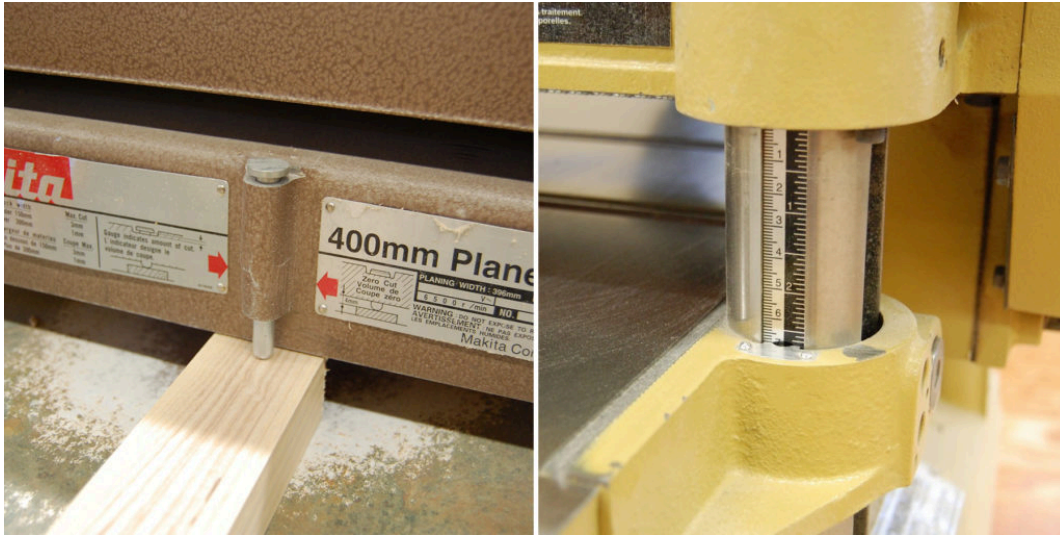

Planer depth gauges

Feed speed control

Many stationary planers have a control for the feed rate. This is usually indicated in feet per minute. A slower feed rate will give a higher quality cut. If multiple passes are needed to bring the stock to final size, the feed rate can be set higher on the initial passes, then reduced for the final pass.

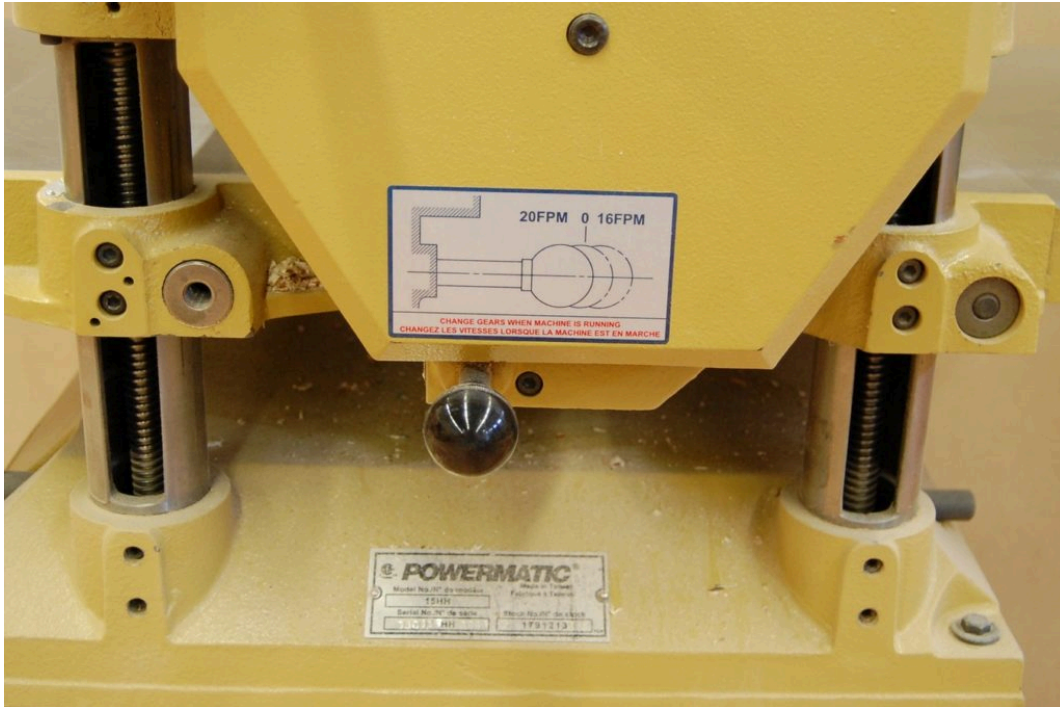

Planer speed feed control

12. Use of the Planer

Safety rules

As the cutterhead in a planer is completely enclosed and the machine feeds the stock rather than the operator, the planer has less potential for accidents than many other woodworking machines. However, there is still potential for injury. Follow these safety rules for the planer.

- The shortest length the planer can accommodate is the distance between the center of the infeed and outfeed rollers plus 50 mm / 2". This ensures at least one feed roller is securing the stock.
- Never place your hands into the machine unless the power supply is locked out.
- A pinch hazard exists between the stock being planed and the table. Ensure your fingers and hands are never between the stock and the bed.
- When planing short stock or planing a heavy pass, the infeed rollers can cause the workpiece to tilt up and then slam down as it engages. Ensure your hands are never under the workpiece at any time.
- As the planer is self feeding, anything that engages with the material being fed will be pulled in to the machine. Be aware of loose clothing or jewelry.
- Stand to the side of the planer on the infeed side to avoid a potential kickback.
- Do not stand between the out feeding stock and anything solid such as a wall or other machine as you could be pinched.
- Small pieces, especially knots, may break off in the planer and be ejected toward the operator.
- Follow all general machine safety rules.

Stock preparation

The minimum length of stock that can be fed through the planer is equal to the distance from centre to centre between the infeed and outfeed rollers, plus about 50 mm / 2". This ensures the material being passed through the machine is always being held by one roller. If shorter parts are to be machined, leave them in multiple lengths for jointing and planing, then crosscut them to size after. This method ensures the parts can be safely machined, and also decreases parts handling.

Material that is to be planed should be inspected for grit, staples or any foreign material that could damage the tooling. Never place stock on the floor where it can pick up grit and small particles that will dull and damage the tooling. Material to be planed should first be jointed to remove any bow, twist or cup.

Before turning on the machine, organize all the parts to ensure they have the jointed face down, and the grain is running in the correct direction to prevent tear out. The cutterhead turns opposite to feed direction. The grain should slope downward toward the end that will be fed in the planer.

Never plane plywood or composites such as MDF, or painted or finished wood, and never place material to be machined on the floor. It will pick up grit that will dull and damage the cutters.

Depth of cut

Check the pieces to be planed at both ends and the middle to determine the thickest dimension. Set the planer

to remove an amount appropriate to this thickness. If the planer is not set for the thickest piece, often it will not pass into the planer and the table must be lowered to catch it up.

It is often necessary to take multiple passes through the planer to achieve the desired depth of cut.

Typically, a stationary planer can remove about 2 mm (1/16") to 4 mm (1/8") in a single pass. Large industrial planers can usually remove more. Small portable planers should not remove more than 2 mm (1/16") per pass. Volume of cut is also a factor, using the entire length of the cutterhead when planing wide panels usually necessitates reducing the amount of material removed in a single pass. The best way to determine if the depth of cut is too heavy is to listen to the machine, if it is excessively noisy or is bogging down, reduce the depth of cut.

Planing multiple parts to a common size

When multiple parts are to be machined to a common size, it is important that all parts are run through the planer at the same depth setting for accuracy. It is difficult to reset the planer to cut exactly the same thickness. When multiple passes are required, plane all the pieces at the same setting before advancing the depth of cut.

Removing large amounts of material

When reducing stock significantly in thickness, run pieces through until they all have a clean side and are the same thickness. Then alternate surfaces with each pass until the desired thickness is achieved. This reduces the chance of warping as potential tension in the piece is released and the moisture content equalizes.

Orientation of stock

The majority of planing operations involve face planing. This is the most stable arrangement as the stock can't tip over. It is acceptable to plane stock on edge as long as it is stable. Wide, thin pieces should be avoided. Whenever possible, multiple pieces should be placed face to face before being run through on edge to increase stability.

Reducing snipe

Snipe occurs when the ends of the piece being planed lift up slightly into the cutterhead and are cut beyond the desired depth. It occurs at the ends when the piece is held by only one roller. The height of the bed or idler rollers can increase the amount of snipe if they are set too high. With many planers, a small amount of snipe is unavoidable.

Running the stock with the ends butted tightly together can decrease the amount of snipe and is good practice when planing multiple parts. It is also good practice to vary the position of the stock in the planer to use the entire width of the cutting head so the tooling wears evenly. A backer board can also be useful in reducing snipe as it isolates the idler rollers. Ensure it has a smooth surface to reduce friction.

Planing thin stock

The planer has a stop that prevents the cutterhead from contacting the table. The minimum thickness that can be planed varies depending on the machine. Be aware that the thinner the stock is planed, the less integrity is inherent in the material. Very thin stock has a tendency to break apart when planing, especially if there is any grain runout. When material less than 12 mm or 1/2" is to be planed, a backer board of MDF or other dense composite material is recommended. They ensure smooth feeding of the material, and reduce the chance of the thin stock deflecting on the bed rollers.



Backer board for the planer

13. Common Operations

There are a few jigs that are commonly used with the planer. These include backers that are used for planing bevels and chamfers, and carriers that allow for planing tapers.

Planing bevels and chamfers

Backers are usually designed to be stationary in the machine. A ledger strip that bears against the infeed table can be affixed to the edge of the jig, preventing it from being pulled into the planer, or clamps can be used to secure the jig to the table. Long strips of material are attached to the backer that supports the workpiece at the desired orientation in the planer. Once the jig is in place, the workpiece is fed through as normal. The jig should be designed to avoid making contact with the cutterhead.



Bevel jig for the planer

To plane tapers, the jig must move with the workpiece so a carrier is required. It is constructed similarly to a backer, but must include a back stop to prevent the workpiece from being pulled off the end of the carrier.

14. Set Up and Maintenance

Compared to other machinery, the planer does not generally require a lot of set up, unless the factory adjustments are out of alignment. Once properly set, these tend to stay in alignment. Changing the knives is the most common maintenance task the planer requires.

Changing the knives

Planer knives are either straight knife, indexing, or carbide insert. For changing indexing and carbide insert, the procedure is the same for [jointer knives](#) of the same style.

There are several methods of securing and adjusting straight planer knives, if possible refer to the machine manual for specific instructions. In general, straight knives are secured using gibs and gib screws in a fashion similar to jointer knives. The cutterhead in a planer may use springs or jack screws to assist in locating the knives at the correct height in the cutterhead. In contrast to the jointer, the planer lacks a reference surface (such as the outfeed table) to use to set the knives. Most planers come with a knife setting jig that is used to properly locate the knives, particularly if they use a spring. The jig rests on the cutterhead, and has a stop at a set distance that that knife references. Some jigs are magnetic, the knife is held by the magnet at the correct height while the gib screws are tightened.

The procedure for removing planer knives is the same as removing jointer knives. Remove one knife at a time and install the new one before continuing on to the next. Ensure the new knives are free of burrs, use a fine waterstone to remove them if required. The knife should be wiped clean of oil or grit before installing. When tightening the gib screws, snug up the end screws first, then the centre, then the intermediate screws while alternating left and right sides. Once they are snug, tighten them in two or three steps in the same order. This method helps keep the blade from shifting during tightening.

Once the new tooling is installed, run a test piece to ensure the machine is operating correctly.

Checking the alignment of the table to cutterhead

There are some adjustments that should be checked with a new machine. The cutterhead should be exactly parallel to the machine table so that the material being planed comes out the same thickness regardless of where it is run along the cutterhead. To check this, run 2 narrow pieces of stock, about 25 mm wide, on the far left and far right side of the table. Measure each with vernier or digital calipers, the thickness should be exactly the same. If it is not, the table needs to be aligned with the cutterhead. You can also use a dial indicator mounted to the machine table and measure the distance to the cutterhead on each end. Ensure that the indicator contacts a smooth portion of the head, partway between 2 of the knives. Adjust the height of the table so the tip of the indicator engages the roller and the dial rotates a few times. Zero the indicator, then measure at both ends of the cutterhead. The dial should read zero on both ends.

Adjustments to correct any discrepancies will vary depending on the exact planer. In general, the adjustment is made by raising or lowering one side of the table. Whenever possible, refer to the machine manual for detailed instructions. Most tables are adjusted by turning the jackscrews (or bushings they are housed in) that the table moves up and down on.

Infeed and outfeed roller adjustments

On most planers the pressure the rollers exert on the workpiece is maintained by springs at each end. On some planers, this can be adjusted. If the material is difficult to feed into the machine, the spring tension on the infeed roller may be too high. Before adjusting the tension to correct for feed problems, ensure other causes have been eliminated, such as a dirty table causing excess friction, dull tooling, or the material binding on the chip breaker or pressure bar.

Locate the adjustment for the infeed roller tension. It will be at the end of and directly above the roller. If the stock is jamming, back off the tension. If a serrated infeed roller is leaving imprints on softer woods, back off the tension. If the stock is not being carried through the cutterhead the rollers may be slipping from inadequate tension, and should be tightened.

Bed roller adjustments

On stationary and industrial planers, bed rollers reduce the friction and allow the stock to feed easily through the machine. They should be set a few thousandths of an inch above the main table. If the planer is sniping excessively, the most likely cause is the bed rollers are set too high. The rollers should be set to the same height at both ends of the table.

Alignment and height can be checked by using a dial indicator.

- Set the dial indicator so the tip is pointing down and can touch the machine table.
- Zero the dial indicator on one end of the machine table near a bed roller.
- Move the dial indicator to measure the height of the bed roller at the top of its rotation. Rotate the roller and observe the needle. It should deviate not more than a few thousandths of an inch. If it does, it is out of round, has a bad bearing or is bent. Note the height of the roller above the table.
- Measure the other ends of the rollers using the same procedure.

The rollers should be at the same height, and no more than a few thousandths of an inch above the table. If required, adjust the rollers. They should be set at the lowest possible height while still projecting above the table. On most planers, the rollers are adjusted by loosening a screw and locknut underneath the table. Adjust and re-check the roller heights.

Checking the extension tables

The extension tables should be in alignment with the main table that supports the work under the cutterhead. If they are high, they can cause sniping, if they are low, they are not adequately supporting the work as they are designed to. The extension tables can be easily adjusted if needed. On stationary planers, the wings are usually bolted to the main machine table. To check for alignment, lock out the machine and lower the table. Place a reliable straight edge across the table surfaces (main and extension) and look for any voids under the straight edge.

To adjust, loosen the bolts just enough that the table will move with a light tap with a soft face dead blow mallet. If the bolts are too loose, it will be difficult to tighten them without the extension table shifting. Use the mallet to move the table into alignment and re-tighten the bolts. If just one side of the table needs to move, it is often easier to loosen just one side and adjust.

Cleaning and lubricating the tables

The most common reason for feed problems in a planer is excessive friction, usually caused by a dirty table and bed rollers that may be contaminated with pitch. If wood with pitch is being planed, small wood chips can get stuck to the bed rollers and cause marking of the surface of the wood as well as causing the workpieces to stall in the machine.

Use mineral spirits and fine (400x) wet dry sandpaper or an abrasive rubbing pad such as a green Scotchbrite™ to remove the contaminants. Wipe with a clean rag, and apply a generous coat of paste wax to the entire machine bed. When wet wood is planed, there is a tendency for it to get stuck in the machine due to higher friction. Rub a block of paraffin wax on the table after every few passes to help keep the material feeding smoothly.

Lock out the machine before performing any maintenance such as cleaning the table or changing the knives.

PART IV

BAND SAW

Band saws use a flexible band of steel with teeth along one edge, which forms an endless belt on a power-driven pulley. Band saws are capable of sawing straight, curved, or irregular cuts in a great variety of materials, including wood and metal. They are available in a variety of models and sizes. The blade can be rigidly mounted within the saw housing and the material moved into the vertical blade.



The bandsaw is a versatile machine that has many uses in the woodworking shop. The size of the band saw and the blade selection determine the type of work the machine can do. Larger band saws are well suited to straight rip cuts, and especially **resawing**. The direction of travel of the blade is down into the table, negating the danger of a kickback when ripping as long as the material is kept flat on the table. Band saws are safer than table saws for ripping, although usually not as accurate. Another advantage of the band saw is the **kerf** is much smaller than a typical circular saw blade, which can conserve material when breaking out parts.

The vast majority of saws have two wheels that carry and power the blade, although there are some three wheel bandsaws. The diameter of the wheel denotes the size of the saw. There are some bench top models of band saws, however these have little place in a professional woodworking shop. The smallest industrial band saws are 14", large saws are available in sizes up to 36". As the column that connects the upper and lower wheel is positioned just to the left of the wheel, the diameter also indicates the throat capacity, or the width of material that may fit between the blade and the column. Because of the blade guard, the throat capacity is usually a small amount less than the diameter of the wheel.

Operators of band saws must possess good working knowledge of the mechanics of the machine. These saws have a tendency to go out of alignment with use, and must be inspected regularly during use to ensure the blade and guides are operating correctly.

A portion of this chapter has been adapted from Trades Access COMMON CORE Line C: Tools and Equipment Competency C-2: Describe Common Power Tools and Their Uses. Download for free from the [B.C. Open Textbook Collection](https://open.bccampus.ca/browse-our-collection/find-open-textbooks/) (https://open.bccampus.ca/browse-our-collection/find-open-textbooks/). The adapted content includes graphics and descriptions of metal band saw blades and blade geometry

15. Parts of the Band Saw

Parts of the band saw

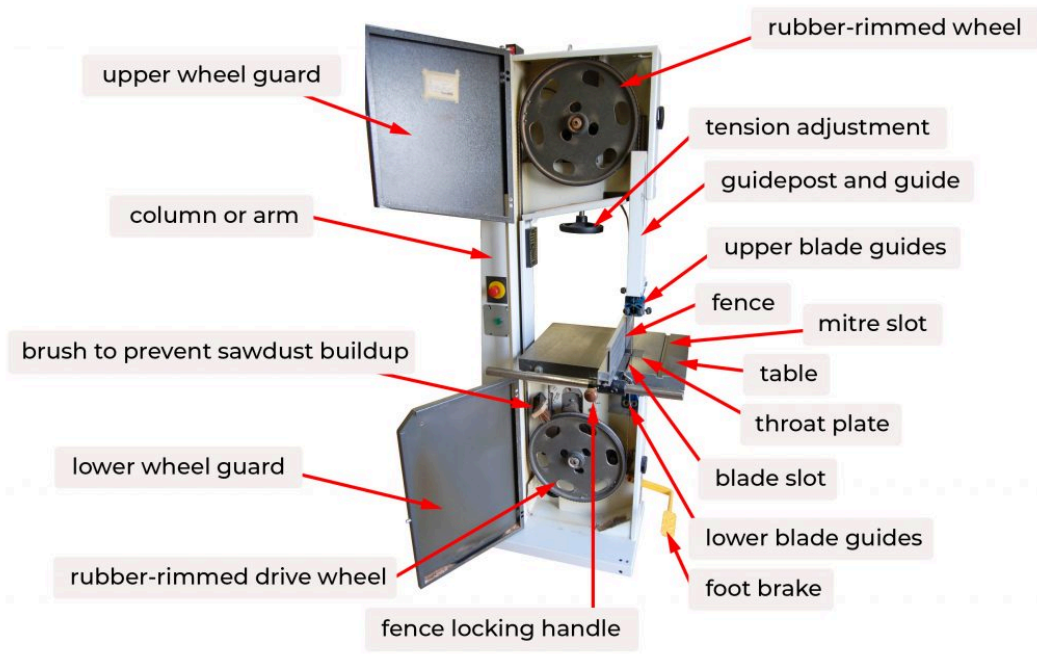

Upper rear part of the bandsaw

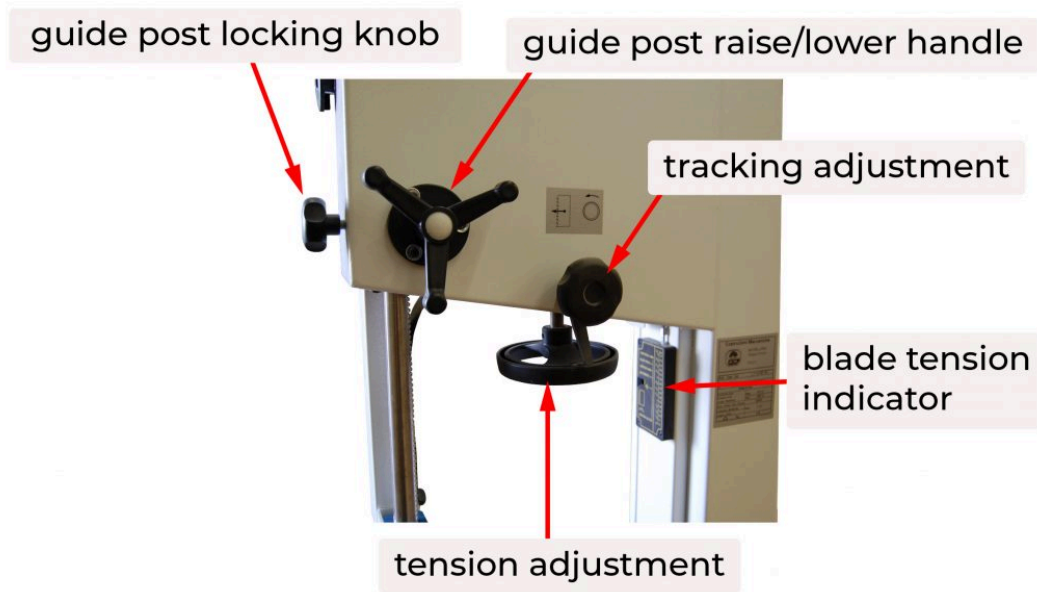

Drive wheel

The lower wheel is connected to the motor with a belt and pulley to power the band saw. Both the drive and

upper wheels are slightly crowned, which keeps the blade running true and helps to keep it from running off the wheel. The wheels have a hard rubber tire that covers the surface that the blade contacts. The tire provides some cushion between the metal surfaces and prevents damage to both. When the blade breaks during operation, shut the machine off as quickly as possible to prevent the blade from damaging the tires.

Upper wheel

The upper wheel is an idler wheel, meaning it is not powered but spins when the tensioned blade is being driven by the lower wheel. The upper wheel can be raised and lowered as well as tilted. These adjustments allow for changing and tensioning the blade as well as tracking.

Column or arm

Every part of the bandsaw above the table is attached to the column. It provides rigidity to the machine between the two wheels. The blade travels up the front of the column which had a guard to cover it.

Table, blade slot

The table is made of cast iron, and should be flat and true. Many band saws have a mitre slot machined into the table for use with a mitre gauge, the slot can also be used to secure various jigs and hold downs such as featherboards. In order to change the blade, the table must have a slot to allow it to be positioned in the centre. A removable round pin is used to keep the halves of the table in alignment. It should be kept in position unless the blade is being changed.

*Bandsaw blade slot
with fixing pin*

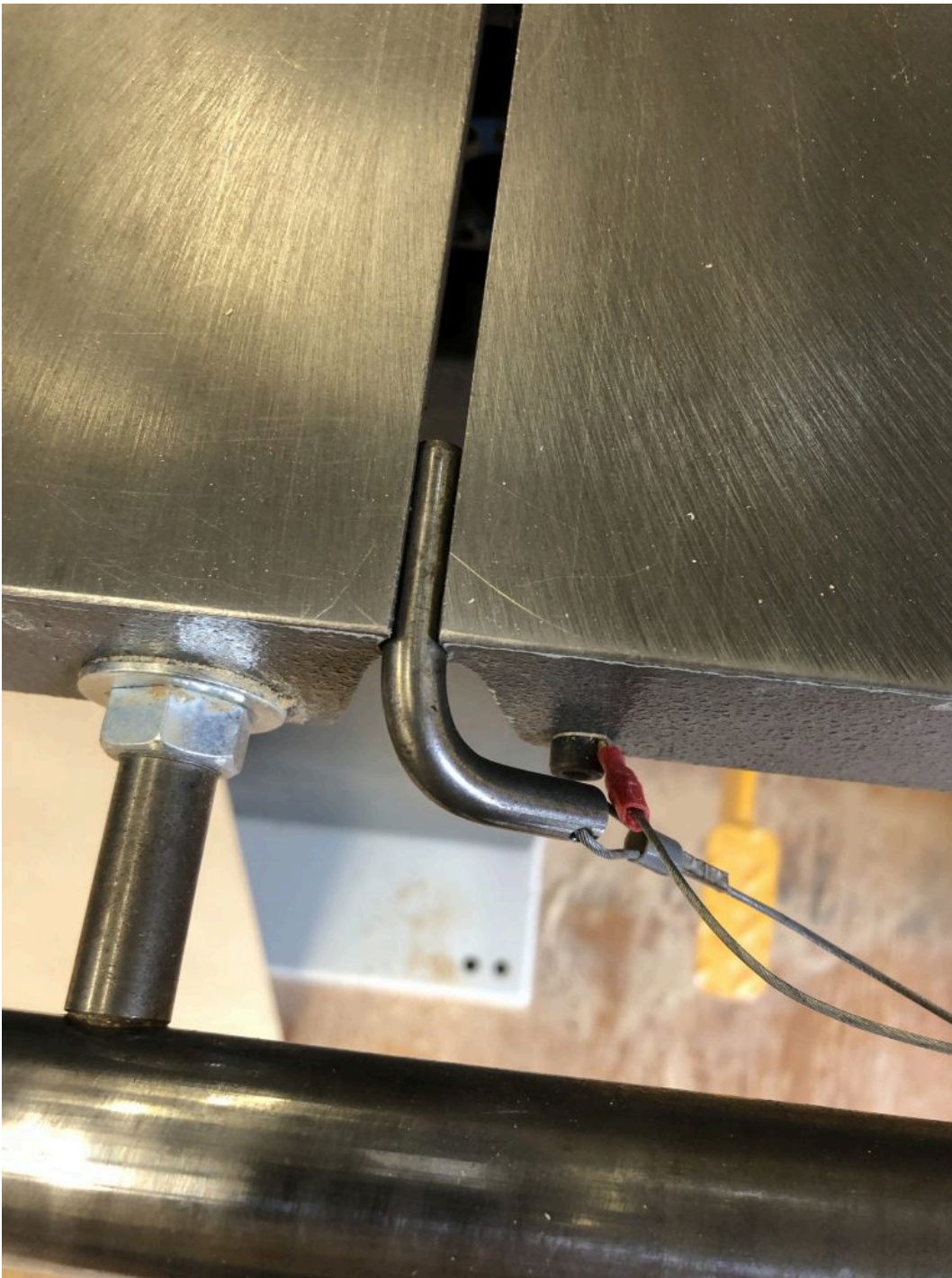

Squaring and tilt adjustment

The table is attached to a **trunnion** assembly that is secured to the band saw cabinet or casting. The mechanism is located directly underneath the table, and is usually secured with a 'T' handle. The table may be tilted for cutting bevels and angles, the same adjustment is used to square the table with the blade. The table-tilt mechanism allows you to tilt the table from 0 – 45°. and has a positive stop at 90°. Because the blades are

flexible and every blade will sit in a slightly different position on the tire, the table should be checked for square every time the blade is changed.



Bandsaw table tilt mechanism

Motor and drive belts

Depending on the saw, the motor may be exposed or housed in the saw cabinet. The drive belts should always be guarded for safety. Some machines (especially larger ones) may have more than one belt to prevent slippage and transfer more power to the wheel. Larger saws and motors may also have a soft start, meaning they take a few seconds ramping up to full speed. This reduces strain on the motor and the connected machine parts. Always allow any electric motor with a soft start to come up to full speed before applying any load.

Tension control

The upper wheel is designed to move vertically in order to apply tension to the blade. Tension is exerted via a strong spring, the adjustment is usually controlled via a handwheel located directly above or below the upper wheel. In order to change the blade, the top wheel is lowered, removing the tension on the blade to the degree that the blade is slack on the wheels. Most bandsaws have a scale that indicates the tension, however they are usually not accurate. Most indicate a tension that is above the actual tension being exerted on the blade. See [set up and maintenance](#) for proper tensioning of band saw blades.



Bandsaw tension control. Note the spring visible through the slot in the square housing.

Tracking control

The upper wheel can be canted forward and backward to keep the blade running in the centre of the wheels. It is necessary to check the tracking every time the blade is changed, and adjust if necessary.

Blade Guide Mechanism

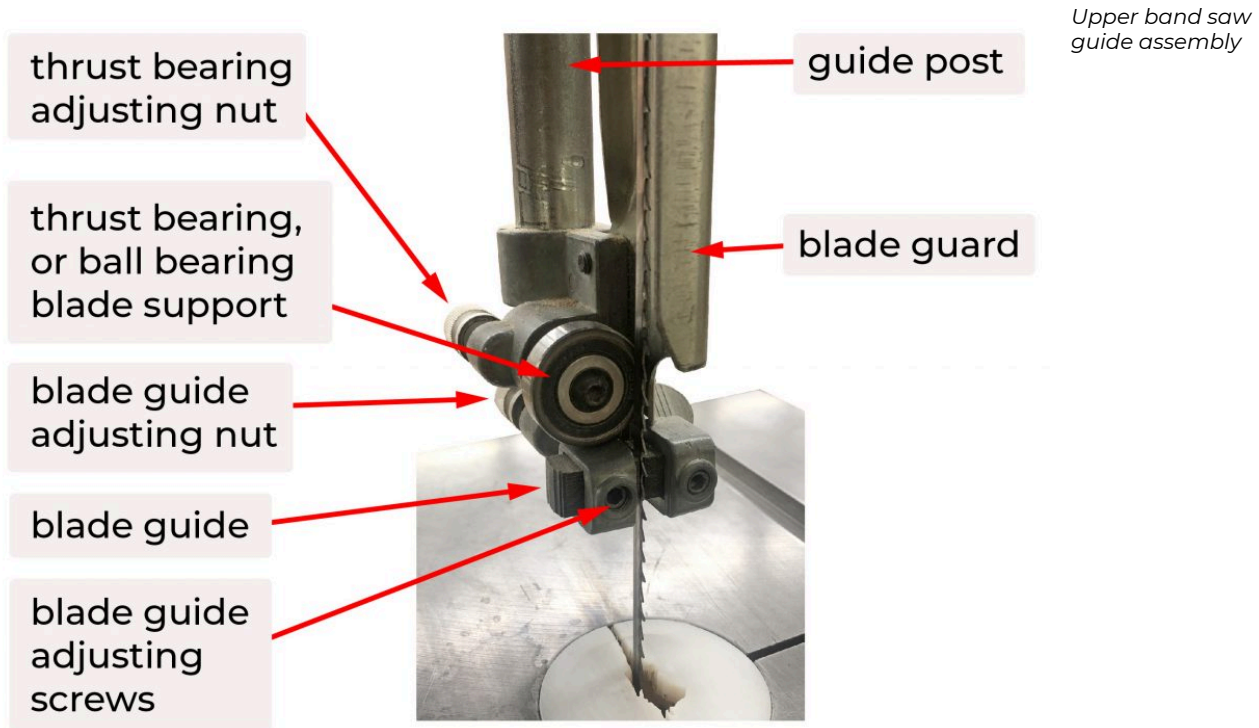

Guide Post

The guide post is a height adjustable assembly that guards the blade above the table, and is the mounting location for the upper guide assembly. The guide post is adjustable for different thicknesses of material by raising and lowering it. It should be adjusted so the guides clear the material being cut by about 6 mm or 1/4". If the guide post is not adjusted and set much higher above the workpiece, the guides are not able to support the blade as well and the cut may not be as accurate. The guide post also has a guard that covers the blade and should always be positioned properly for safe operation.

Blade guards

The band saw is guarded at all points except the area between the table and the guides. Ensure the guide post which includes a guard is adjusted to the correct height above the workpiece. The wheel guards are hinged to allow access to the interior of the machine for maintenance and changing the blade.

Blade guides

Band saws have two sets of guides, one above and one below the table. Each set consists of three individual guides: one that supports and limits travel at the back of the blade, and one on either side.

As material is fed into the blade, the force exerted acts to push the blade backwards and off the wheels. The rear support is known as the thrust bearing or blade support bearing. It is most often a ball bearing mounted just off-centre to the blade. The thrust bearing is adjustable front to back to account for different blade thicknesses. When the saw is running but not under load, the blade should not make the bearing spin. As soon as the cut engages, the blade should cause the bearing should spin. This extends the life of the bearing as it is only turning when wood is being cut.

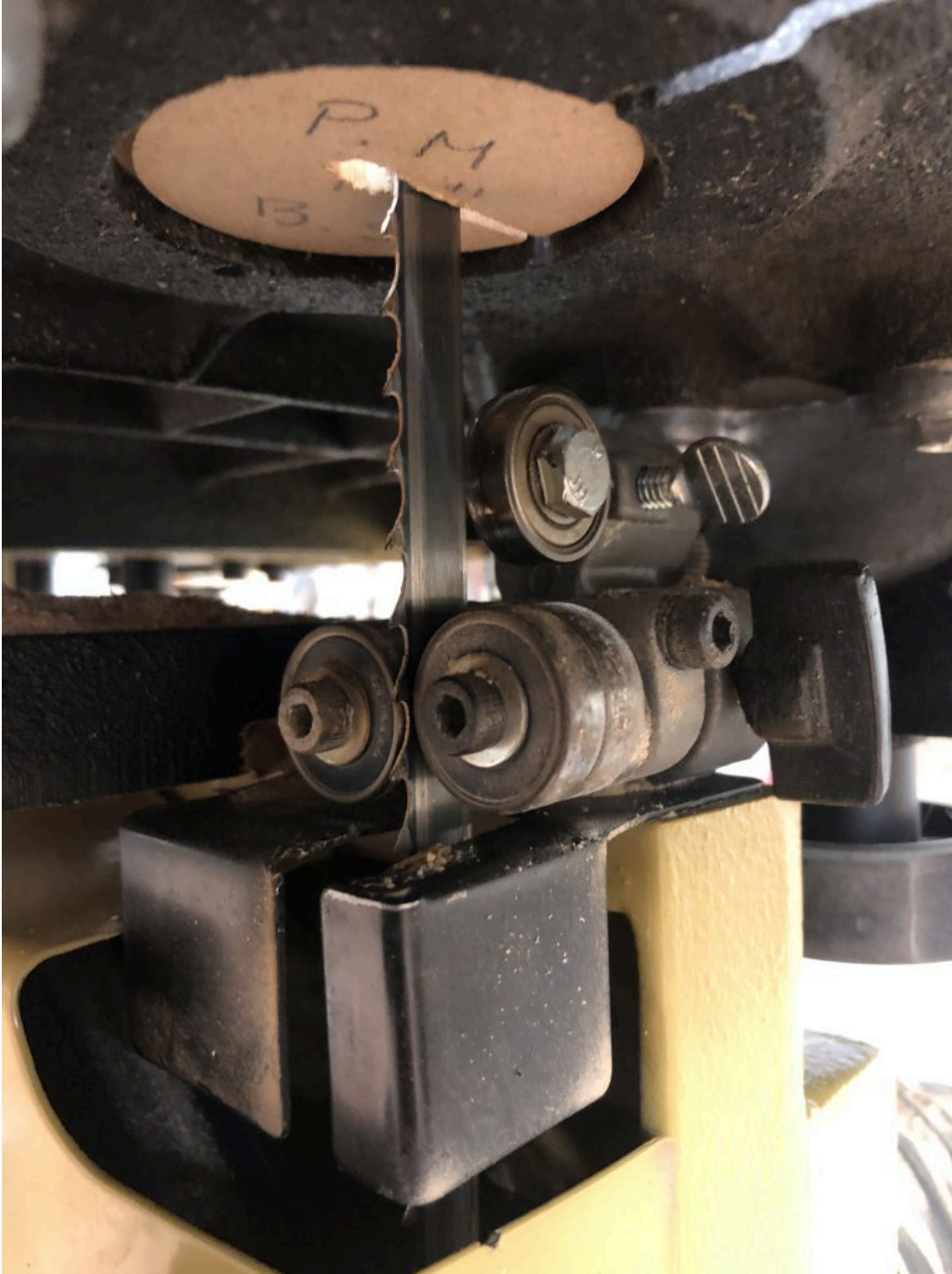

Lower bandsaw blade guide assembly

There are several different types of side guides. The most common are bearings and guide blocks. Both support

the side of the blade, and should be adjusted to provide minimal clearance. A sheet of paper is about the clearance required. The guides should be set back far enough that the teeth clear the guides. A third type of guide uses small ceramic blocks that can be set with the blade just-touching them. They are low friction, resulting in cooler running blades. They are extremely long-lasting in comparison to standard ball bearings.



Upper bandsaw guides, bearing type



Upper band saw guides, block type



*Upper bandsaw
guides, ceramic type*

16. Tooling

Bandsaws are versatile, capable of a variety of cutting operations. Selecting the correct blades and maintaining them is key to the proper functioning of the machine. Band saw blades are defined by their grades of steel, tooth formation, tooth set, blade width, and teeth per inch.



Band saw blades

Grades

Grades include carbon steel blades, bi-metal blades, and carbide tipped blades. Each blade is used differently depending on the materials involved in the cutting process. Bi-metal blades are made by welding spring steel for the back with high speed steel for the teeth. They are used for cutting metal, and are not usually found on wood cutting bandsaws. Carbon steel blades are commonly used for wood, and are available in two types, flex-back and hard-back.

Flex-back carbon steel blades are made from carbon steel with a flexible back that is suitable for absorbing contour (curve) cutting stresses. Only the teeth are heat-treated, with an unhardened flexible back that makes these blades more resistant to fatigue from the stress of curve cutting, resulting in longer blade life when used at high operating speed rates. They are recommended for softer materials. Hard-back blades have both hardened teeth and bands, making these blades ideal in situations where straighter cuts or heavier feed pressure are required, and are suitable for harder materials.

Carbide blades have individual teeth welded to a tough backing band. They are used for cutting very hard and tough materials. The cost of these blades is significantly higher than for other types of bandsaw blades, and for woodworking are a specialty type. They are excellent for resawing thin, wide solid wood veneers, and several manufacturers make a carbide blade for this purpose.

Tooth Formation

The three main types for tooth formation, or shape are regular, skip, and hook.

Regular-tooth formation

Band saw blades with regular teeth are used for straight and curved cuts in woods and most ferrous and hard non-ferrous metals. These blades have teeth that are proportionally spaced, and can be considered suited for general-purpose cutting and contour sawing. Regular blades are ideal for cutting thin materials with a fine finish.



Skip-tooth formation

Skip tooth blades have widely spaced teeth at a 0 degree rake angle to prevent clogging when cutting soft wood. A 0° rake angle is also preferred in resawing applications. It is similar to the standard tooth style but with less teeth (every other tooth being removed).



Hook-tooth formation

The hook-tooth blade is best for fast cutting. The large, rounded gullets are capable of fast chip removal. Thin materials should not be cut with this tooth style due to the wide spacing of the teeth.

Hook tooth blades have a deeper **gullet**, and a positive 10 degree rake angle; the forward slope of the tooth requires less downward pressure to cut. This helps the blade to feed into the material more aggressively. The result is faster cutting rates with fast chip removal. Hook tooth blades are commonly used for long cuts in thicker wood.



Hook- and skip-tooth types are available in 3 to 6 teeth per inch. Regular-tooth styles range from 6 to 32 teeth per inch. The number of teeth per inch affects the cutting speed of a band saw and the size of stock it is best suited to cut. Blades with a large number of teeth per inch are able to cut small, thin pieces of materials but are slow for cutting large sections. Blades with few teeth per inch cut faster but are too coarse for cutting thin sections of materials.

Tooth set

Set is defined as the left and right positioning of the teeth to provide a wider cut than the thickness of the blade. The wide cut provides clearance for the blade within the cut, preventing binding and overheating. An appropriate set provides a balance between sawdust and air in the space between the body of the saw blade and the material it is cutting. A good appropriate set is about 80/20, with 80% sawdust and 20% air being ejected. Too much set results in too much air and not enough sawdust and can leave tooth marks. Too little set restricts the airflow and limits the blade's ability to pull sawdust out of the cut. This results in packed sawdust in the kerf and leads to premature blade breakage.

There are two types of tooth sets available, the raker set and the wavy set.

Raker or Regular Set

Raker set consists of a repetitive pattern with one tooth set to the right, the next to the left, and the third (called the raker tooth) without a set. Hook- and skip-tooth blades have raker set teeth.

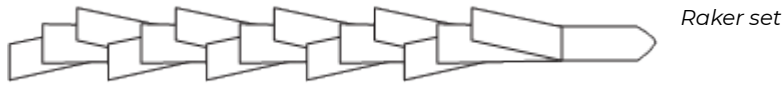

Wavy Set

A wavy tooth set has groups of teeth set left and right, separated by unset raker teeth. Wavy set blades are made primarily with the small teeth recommended for cutting thinner metals. They are not common as a wood cutting blade, but are used occasionally for very fine cutting blades.

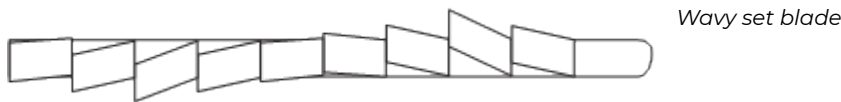

Blade width

Band saw blades are available in widths ranging from $3/16"$ / 5 mm in. to $1 1/4"$ / 32mm. The narrower blades are able to cut curves of a smaller radius than are the wider blades. Wide blades are used for straight cuts, including resawing operations. Refer to the chart to determine the correct blade width. You will want to select the widest blade that can still make the curve cut you require. In general, $3/16"$ / 5 mm widths are used for tight curves, $3/8"$ / 10 mm for multi-use, and a minimum of $1/2"$ / 12 mm for resawing and larger curves.

BLADE WIDTH:

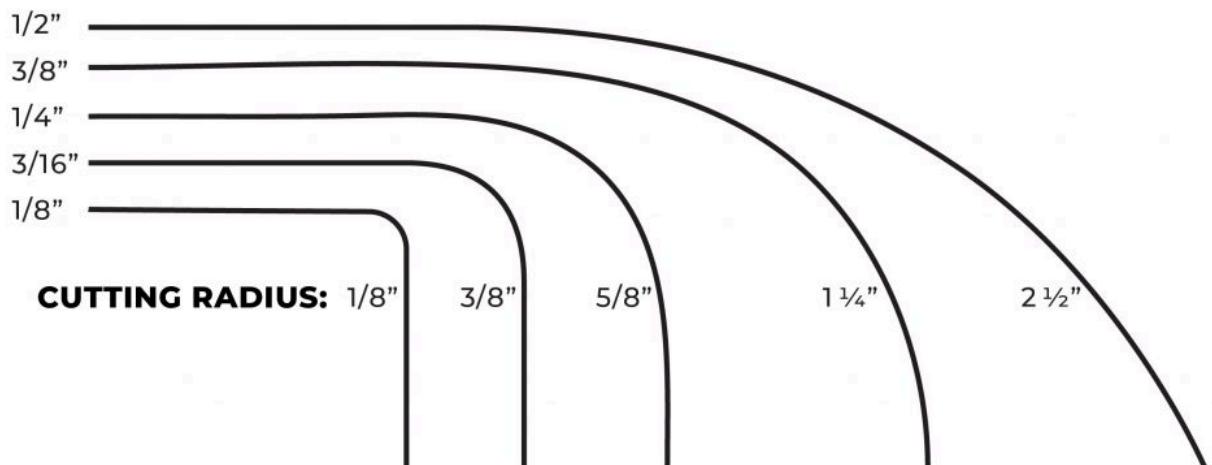

Number of teeth

The number of teeth on a bandsaw blade are counted per inch of blade, and is referred to as teeth per inch or TPI. In general, a 10-20 TPI blade is used for smooth cutting, a 6-10 TPI blade is used for general purpose uses, and a 2-3 TPI is used for quick cutting, especially ripping.

Blades with fewer TPI (more space between the teeth) can cut faster, are a good choice for thicker materials, softer wood and wet wood. Blades with more TPI cut smoother, are better suited to thin materials, harder and drier woods.

WOOD

Teeth per inch for a given thickness

TPI	Minimum Material Thickness
32	3/32"
24	1/8"
18	5/32"
14	1/4"
10	5/16"
8	3/8"
6	1/2"
4	3/4"
3	1
2	1 1/2"

17. Use of the Band Saw

Safety Rules

Before starting the saw:

- Ensure all guards are in place
- Ensure the proper blade is installed for the type of cut being performed, and that the teeth are pointing down to the table. It is possible to install the blade backwards
- Ensure the proper blade tension is set. Note that some bandsaws have a mechanism for quick release of tension that is used after every cut or at the end of the day
- Ensure the blade is tracking properly.
- Adjust the guide post so the upper guides are no more than 1/4" / 6 mm above the workpiece
- Inspect the guides (side and thrust bearings) both above and below the table for proper adjustment

While using the saw:

- Allow the saw to reach full speed before feeding the stock
- Cut at the correct feed rate. Blades with a higher TPI need a slower feed rate
- If the blade starts to track forward and backward in relation to the thrust bearing during operation, or if you hear a rhythmic clicking sound while the saw is running, shut it down immediately. This is usually a sign that the blade is about to break. Lock out the saw and inspect the blade for cracks
- If the blade breaks during use, shut off the power immediately. If the saw has a foot break, use it to stop the saw as quickly as possible to prevent damage to the interior of the saw
- Do not twist or apply side pressure to the blade, it can cause it to break
- If the blade breaks during use, do not stand to the right of the saw as the broken blade can protrude in this position.
- Keep your hands a comfortable distance from the blade. If you slip and your hands are too close to the blade, you could be injured.
- Be particularly aware of where your hands are positioned near the end of the cut. As the saw completes the cut, there is no resistance to the force being applied by the operator and the parts will move forward suddenly. If your hands are in the way, you will be injured.
- Keep the workpiece in contact with the table at all times. With a bandsaw, the direction of force is down, if the workpiece is unsupported above the table, the blade will grab it and force it down on to the table.
- Never crosscut round stock that is not properly supported and secured in a carrier. The leading edge of the round will be above the table, posing a hazard. The blade can grab the wood and spin it out of your hands
- Use a push stick to complete cuts any time your hands are close to the blade
- Do not use dull blades, they cause you to apply excessive force which increases the risk of an accident
- Follow all general machinery safety rules

Stock preparation

Unlike the table saw, the bandsaw can be used to cut stock that is not perfectly flat or straight. While the face being cut needs to stay in contact with the table, boards that are warped, cupped, or otherwise out of flat

can be cut on the bandsaw as long as the piece is mostly supported in the area where the blade is cutting. Because the direction of force of the blade is down onto the table, stock can be freehanded through the blade without needing a straight edge. The bandsaw is the right tool to straighten stock in preparation for other machines such as the table saw and jointer.

There is no minimum length or size of stock that can be safely machined on the bandsaw, but small pieces must be guided in a way that doesn't risk running your hands into the blade. Use push sticks for small parts, or use appropriate work holding devices.

When cutting solid wood, always inspect it for foreign objects such as staples as these will prematurely dull or damage the blade and can pose a safety hazard. Never place any wood that will be machined on the floor as it will pick up grit and other hard debris and damage cutting tools.

The bandsaw can be used for cutting composite materials such as MDF and plywood. With the correct blade, it can also be used for cutting metals, plastics, paper products, and other materials. Always use a blade designed for the materials being cut.

18. Common Operations

The bandsaw is a versatile tool that is capable of performing a wide variety of operations, from cutting fine curves to resawing large timbers. Different bandsaws are manufactured that are better suited to some work than others; large bandsaws are usually used with wide blades for straight ripping and resawing, while small bandsaws are fitted with narrower, finer blades capable of cutting shapes and curves. Many woodworking shops will have more than one type of bandsaw, each set up for different cutting operations.

Bandsaws can be used for the following operations: ripping, resawing, crosscutting, bevel cuts, circle cutting, curve cutting, and pattern cutting.

Ripping

Freehand ripping

Ripping on the bandsaw can be done freehand, or without the need for an edge guide. It is used when a smaller bandsaw lacks a fence or there are only a few pieces to be cut, or when the bandsaw is being used to straighten an edge. Freehand ripping is used to trim the edge of a board out of plane with the existing edge for the purpose of favorably aligning the grain when performing rough break-out.

When freehand ripping, it is useful to mark the line of cut on the workpiece to aid in sawing a straight line. This can be marked with a straight edge and pencil, or for longer pieces with a chalk line. A chalk line is particularly useful when 'straightening' the grain to the edge of the board.

When freehand ripping, use one hand to guide the stock just ahead of the blade, while using the other hand at the end of the workpiece to guide and steer it through the cut. Your forward hand will act as a fence to achieve a straighter cut.

Ensure your hands are not in the path of the blade near the completion of any cut. When the piece is cut completely through, there is no longer resistance and the piece has a tendency to 'jump' forward suddenly. Also, as the cut progresses, the piece can break apart suddenly and there is the potential for your hands to make contact with the blade.

Guided ripping

As on the table saw, a fence can be an aid to ripping, and is necessary for performing repeated, accurate and efficient cutting. Bandsaw fences do not have scales, a tape measure or ruler is used to set the distance between the fence and the blade. On raker-type blades, use the tooth that is closest to the fence to set the distance. Always wait for the saw to come to a complete stop before bringing a measuring device up to the blade. Once the fence is set to the correct distance, the piece can be guided through the blade. When making narrow cuts, use a push stick to aid in pushing the stock past the blade. The push stick can be used on either side of the blade, pushing either the workpiece or the offcut. Unlike a table saw, there is no kickback danger due to the work being trapped between the fence and the blade. In some cases, it may be easier to lay the push

stick horizontally on the table to guide the work. If the push stick will be cut by the blade, it should be kept in contact with the table to prevent the force of the blade from slamming it down on the table.

Adjusting for lead, checking for drift

Also see [set-up and maintenance](#) for more information on adjusting for drift.

Lead

If a bandsaw blade becomes duller on one edge, it will cut more aggressively on the sharper side, to cut a straight line, the workpiece needs to be angled relative to the blade, compensating for the duller side of the cut. When cutting freehand, the operator adjusts the angle of the workpiece as it is cut, if a fence is being used, the fence should be adjusted to the blade, or the blade should be repositioned on the wheel. To correct lead, the blade can be dulled slightly on the sharper side by using a honing stone, or the blade can be replaced.

Drift

As the position of the blade forward and back on the crowned wheels can vary when it is installed, the angle of the teeth changes slightly relative to the fence. The rip fence needs to be checked when a new blade is installed and periodically throughout its life to ensure proper alignment with the blade, this is called checking for drift.

Resawing

The most efficient and safest tool for resawing is the bandsaw. While there are models manufactured just for this purpose, any bandsaw can perform resaw cuts. Bandsaws are well suited to resawing as they have the capacity to cut very wide stock, have thinner kerfs relative to other machines, and don't have a risk of kickbacks.

Resawing is cutting through the thickness of a board to make two or more thinner pieces. It is the technique used to create bookmatched panels, shop-sawn veneers, and plies for bent laminations.

Wider blades with a small TPI are well suited to performing resaw cuts. The wide blade reduces deflection, increasing the accuracy of the cut, while a small number of teeth in the cut makes for efficient, quick sawing through wide stock and clears the sawdust without packing the kerf and overheating. For wider resaw cutting, a slower feed rate may be necessary.

When resawing, a standard rip fence or a resaw pin (also known as a pivot block) may be used. Before attempting resaw cuts, ensure the blade is perfectly square to the table, and that either the fence or resaw pin is square to the table. If they are not, there can be significant runout over the width of the cut.

When using a fence, it is important to ensure the fence is properly set to the blade with little drift. If using a resaw pin, the operator accounts for lead by steering the workpiece through the cut, keeping the cut parallel to the blade. When clamping the resaw pin on the bandsaw table it is important to line-up the highest point of the curve in the pin with the very tips of the blade since that is where the cut is occurring. If you were to line the resaw pin up with the centre of the blade, for example, the pivoting would not work to guide the blade through for a parallel cut.

Crosscutting

Rough crosscutting and mitring cuts can be made on a bandsaw, but are better suited to other machines, such as the table or mitre saw. They can be made freehand, or with the use of the mitre gauge.

Bevel cuts

Bevels and angled cuts can be made on the bandsaw by tilting the table. The blade remains stationary. With the table tilted, the material can have a tendency to slide on the table, putting lateral pressure on the blade. Good material control is necessary. Depending on the make of saw, the factory blade insert may need to be removed and replaced with a shop-made insert that will allow for the blade to run at an angle. If a tight-fitting, thick insert is left in the saw and the table tilted, it will bend and damage the blade.

To set-up for a bevel cut, locate the lock under the table, release it and tilt the table to the desired angle before locking the table in position. A sliding T bevel is useful for setting the angle. Straight bevel cuts can be made using the fence or a resaw pin, or freehand. Freehand bevel cuts are an efficient way to shape curved parts without the construction of jigs, as would be necessary with other methods. When making curved bevel cuts, it is important to keep the workpiece rotating so the radial line of the curve is perpendicular to the blade.

Circle cutting

A circle cutting jig for the bandsaw uses a centre point mounted on a sliding strip to vary the diameter of circles which can be cut. The radius of the circle is simply set by measuring the distance between the centre point and the bandsaw blade, and fastening the sliding strip in that position.

Underneath the auxiliary tray there is a wooden strip which fits in the mitre slot of the bandsaw table. This strip enables the tray to be moved in and out of the saw. The circle cutting jig will only work properly when the front edge of the saw blade is exactly even with the centre point. For this reason, a stop block is fastened to the front of the auxiliary tray to stop the tray at exactly the place where the centre point and blade edge are even. If the tray goes in too far, the jig will cut on a spiral inwards and if the tray does not go in far enough the cut will spiral outwards.

To use the bandsaw circle cutting jig a piece of wood is mounted on the centre point with the tray off of the saw. The auxiliary tray is then slid into place with the bandsaw running. The track on the bottom of the tray guides the tray and wood for a straight cut. The tray will stop when the stop block makes contact with the front of the saw table top. At this point the wood will have a saw kerf leading in from one edge. With the tray in this position the wood is rotated around the centre point until it returns to the original position. The tray can then be carefully backed away from the saw blade and removed from the machine. Once the wood is clear of the blade the scrap material may be lifted off the circle removed from the centre point. If more circles are to be cut, another blank of wood may be placed on the centre point, and the sequence repeated.

Curve cutting

With the correct blade, bandsaws excel at cutting curves and irregular shapes. The tightness of curve that can be cut is directly related to the width of the blade, the narrower the blade, the tighter the radius that can be cut.

The other factor is the set of the teeth. Blades with more set will cut curves easily, while blades with little or no set will not perform these cuts. The greater the set, the tighter the radius the blade will cut.

When cutting curves, use the widest blade that will handle the radius of the cut. This will result in a fairer, smoother curve requiring less clean-up. If the back of the blade rubs on the kerf, the blade is too wide for the given radius. For tighter curves, or when narrower blades are not available, relief cuts (straight cuts) should be made which allow the waste to break away and prevent the blade from binding in the cut. Relief cuts should be short, as the workpiece will have to be backed out of the cut. When backing the blade out of any cut, there is the potential to pull the blade off the wheel. Avoid backing out of long and curved cuts. Pay close attention to the position of the blade, ensure it is aligned with the kerf as the workpiece is backed out.

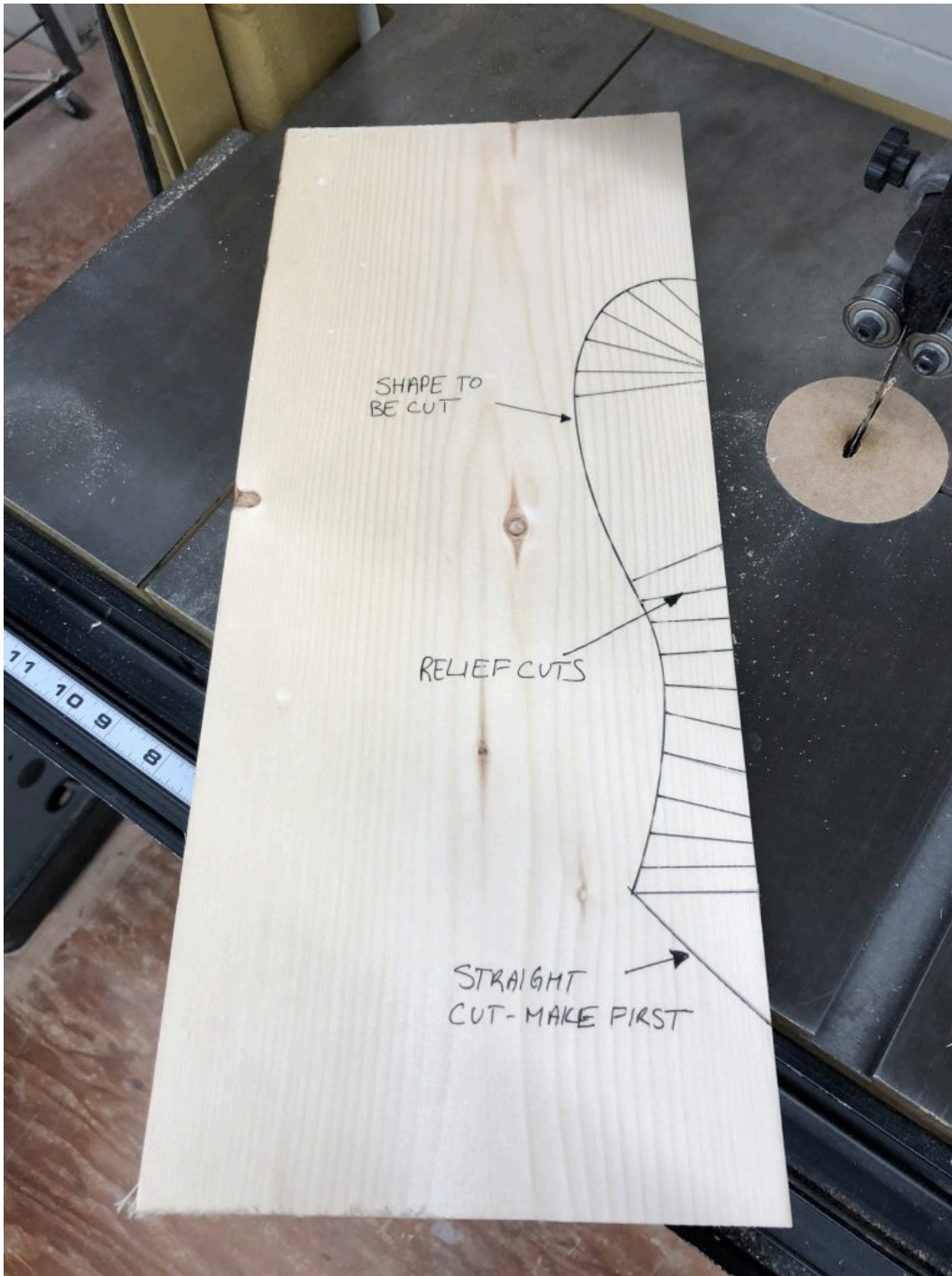

Example of a curve with lay-out for relief cuts

Making short relief cuts

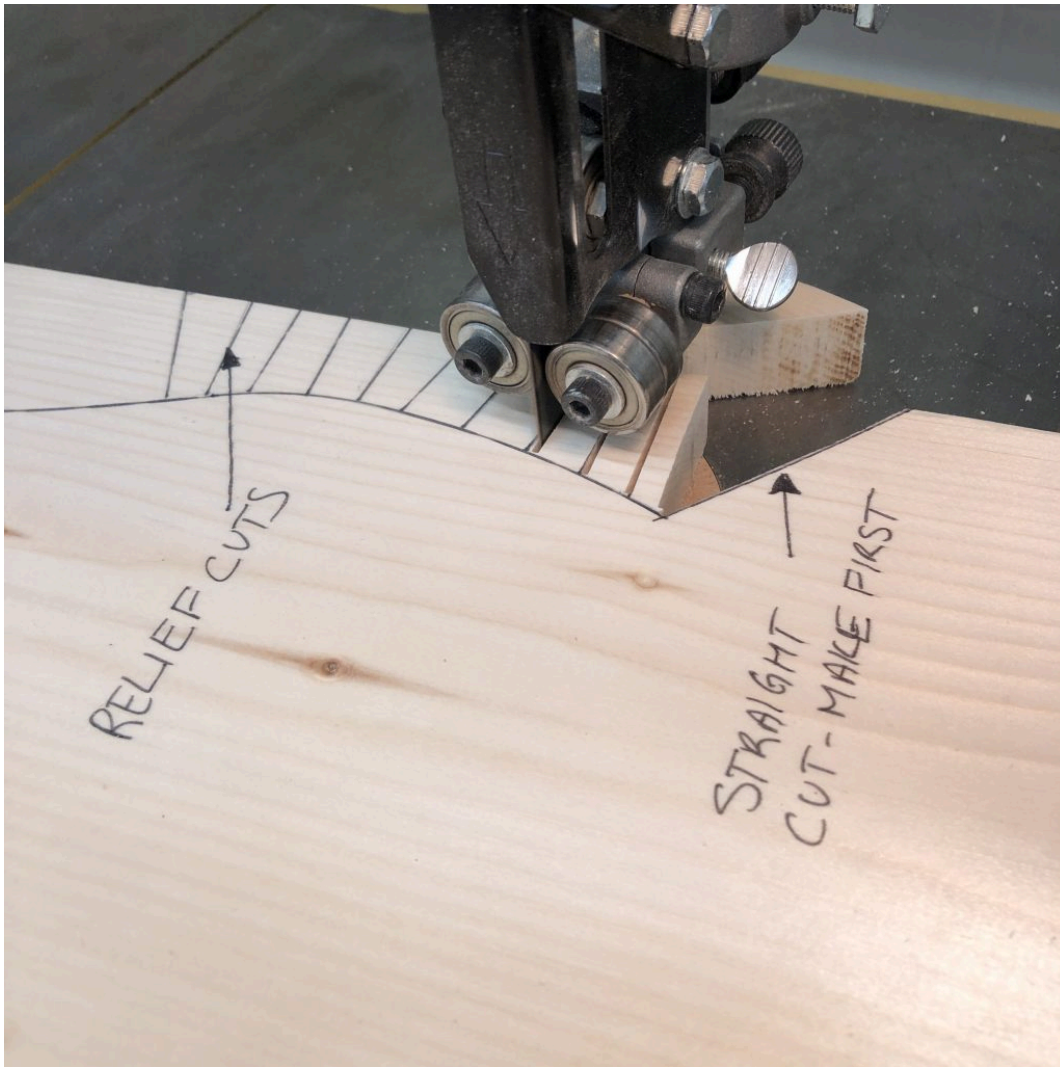

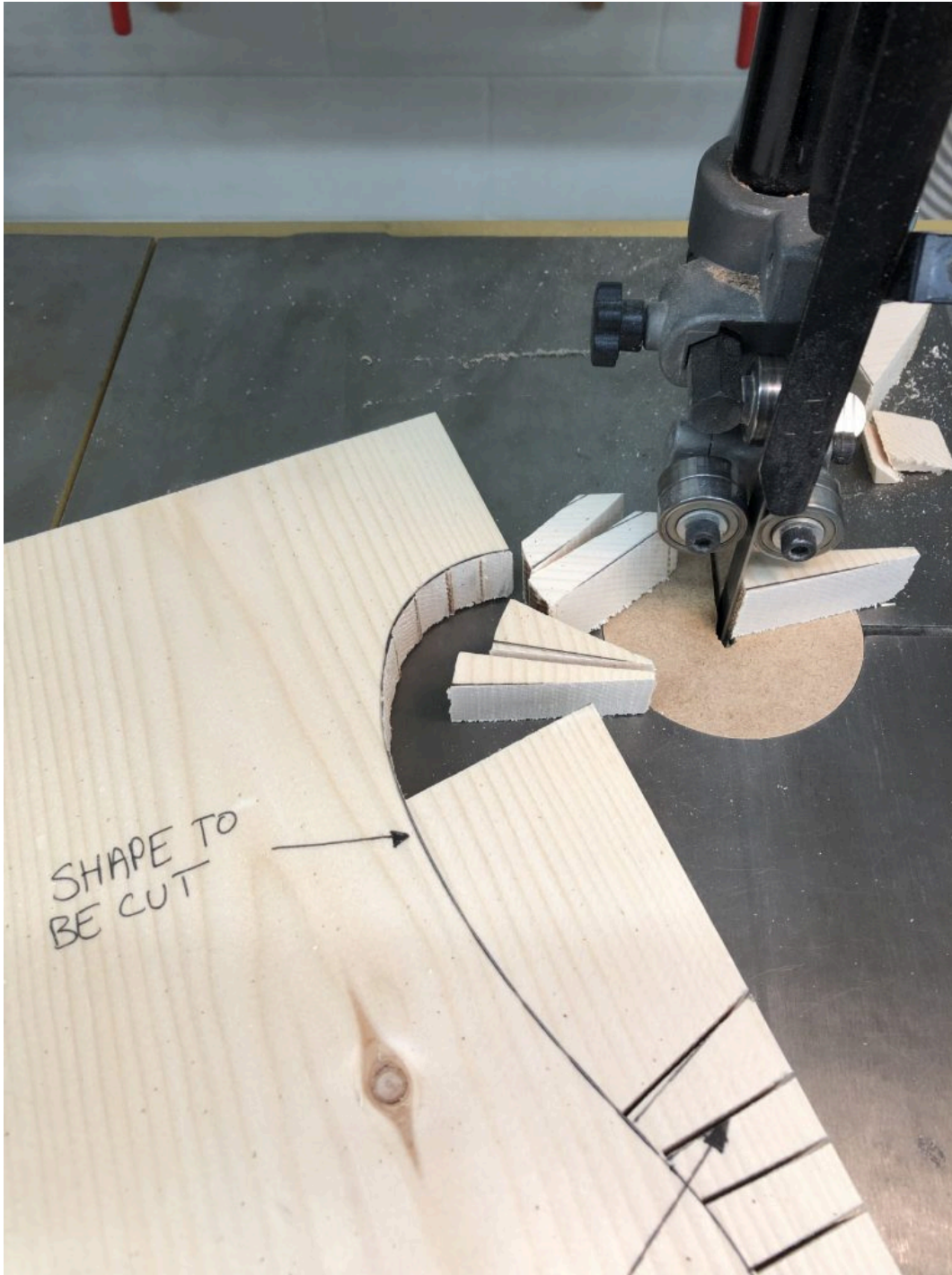

Cutting a curve after the relief cuts have been made

A resaw pin type of guide can be used on the bandsaw to cut parallel curves. Starting with a curved workpiece, set the distance from the pin to the blade the required distance. Run the curved edge along the resaw pin, pressure against the guide pin allows a curved cut to be made parallel to the original edge.

Pattern cutting

A template can also be used to make repeated identical cuts on the bandsaw.



Pattern cutting follower, template and workpiece

A curved or straight pattern is fastened to the underside of the wood to be cut with a small finishing nail or double-sided tape. The template is run against an auxiliary guide which is clamped to the bandsaw table. This guide is made to fit around the blade so that the edge of the guide is flush with the right side of the blade.

The auxiliary guide must be clamped to the bandsaw table on top of a spacer which is slightly thicker than the piece of wood being cut so the auxiliary guide won't rub the off-cut of the piece being cut.



Bandsaw template follower with template and workpiece in position for cutting



*Bandsaw template
follower position
relative to the blade*

Cutting round and square stock using a V block

A simple V block allows for the cutting of round, square and rectangular stock. The block can be positioned to resaw material, producing half-round piece with round stock, or triangles or octagons with square stock. It can also be used for cutting slots for tenon wedges in round stock, as well as diagonal slots in square stock. Dowels and any round stock tend to rotate during a cut, causing the cut to be out of plane. To prevent this, a vertical splitter bar behind the blade can be added to prevent the piece from twisting during the cut.

The V block should be secured to the fence or to the table to prevent it from moving, and to set its position relative to the blade.



Square stock being cut in a V block. The V block is spaced from the fence to allow the guide post to be lowered to the correct height without hitting the tall rip fence



*Round stock being
kerfed using a V block*

19. Set Up and Maintenance

All machines require set up to achieve accurate and repeatable results, and maintenance to keep them working properly. The following information will guide you through these tasks. Learning to properly set up and tune the machinery you use on a daily basis is important in keeping the entire shop efficient and productive.

In all aspects of set up and maintenance, use correct lock out procedures before beginning.

Squaring the blade to the table

Raise the guide post well above the table. Loosen the table lock, tilt the table and ensure there is no sawdust between the table and positive 90° stop. Return the table to position and lock it. Using an engineer's square or try square, check the angle of the blade to the table. If it is not 90°, loosen the table lock and adjust the angle of the table until it is square. Adjust the positive stop until it touches the table. You may need to tilt this table to adjust the stops, adjust and re-check until the positive stop is in the correct position.

Changing blades

- Back all guides completely off of the blade, above and below the table
- Remove the tension completely from the blade using the tension control handwheel or knob
- Remove the table pin
- Carefully pull the blade off of the upper and lower wheels, guiding it out of the table slot
- Coil up the blade
- Clean all dust from the interior of the saw, paying particular attention to the rubber tires on the wheels and the guides
- Inspect the drive belts for wear, replace if necessary
- Uncoil the new blade, being careful of the sharp teeth- leather gloves are recommended. Ensure you have adequate clearances around you
- Inspect the blade, making sure the teeth are pointing the right way. If they are not, turn the blade inside-out
- Carefully work the blade into the saw, feeding it through the blade slot and onto the tires. Try not to touch the teeth to the metal parts of the saw
- Take up some of the slack with the tension adjustment, until the blade is just-taught but able to be moved forward and back on the wheels
- Position the blade so it is as centered as possible on both the upper and lower wheels. This will greatly reduce any drift in the blade.
- Increase the tension to the recommended setting
- Carefully and slowly rotate the upper wheel by hand. *Be extremely cautious when rotating the wheel by hand.* There are pinch points in the saw that can badly damage fingers. Observe the blade, it should keep its position on the wheel, and not touch the guides.

- Incrementally adjust the tracking, if needed. It usually doesn't need much adjusting, if at all, after the initial purchase and set-up of the saw. See "Adjusting the tracking" below
- Jog the saw by turning the saw on and shutting it off immediately. This will test the set-up of the machine, if it is off the machine will be powered off immediately, mitigating any damage. Make any necessary corrections to the tracking.
- Let the saw run for about a minute to ensure the blade is settled in and tracking properly
- Lock out the power, and set the guides above and below the table. See "Setting and adjusting the guides" section below
- Close all covers and replace all guards
- Re-connect power to the machine
- Jog the saw again, to test the guide set-up
- If the saw has a fence, it will need to be checked and adjusted for drift. See "Adjusting for drift" section below.

Most bandsaw blades have a break-in period where the cutting feed rate is slowed significantly to prevent premature breakage. Refer to the manufacturer's blade specifications.

Blade tensioning

Band saw blades are tensioned according to their width, with wider blades requiring more tension than narrow ones. The tension scale on the saw corresponds with blade width. There are tension meters that can be purchased to measure blade tension, however they are not common in most shops.

It is important to maintain the proper tension for several reasons. If a blade is under-tensioned, it has a tendency to wander in the cut, producing inaccurate results. Straight cuts can be made with the blade at a lower tension as there is less lateral force on the blade. Higher tension has the effect of stiffening the blade in the cut. Having too much tension is also undesirable as it stresses and weakens the blade, resulting in premature failure. It is a best practice with a bandsaw to remove the tension from the blade when it is not in use. Some shops remove the tension at the end of the day. If the saw is sitting for long periods of time between uses, the tension should be removed. Some band saws have a mechanism that quickly and easily allows for the tension to be removed and replaced to the same setting.

Be aware that if the saw is inadvertently started without the tension engaged, the blade can be forced off the tires or be damaged.

If there is no scale or it is unreliable, the blade can be tensioned using the following method.

- Lock out the machine, and raise the guard about 150 mm or 6" above the table.
- Apply moderate pressure on the side of the blade with your finger.
- The blade should deflect about 6 mm or 1/4", but no more.

This method is not highly accurate. As you use the band saw you will get a feel for what proper blade tensions is. If the saw is being used for curved work and not performing well (wandering in the cut), try increasing blade

tension slightly. A good starting point is to tension it to the next highest setting, for example, try tensioning a 3/8" blade to the 1/2" setting.

One of the most important operations that rely on proper tension is resawing. Larger saws can have resaw capacities that exceed 18", these must have the blade properly installed and tensioned for successful outcomes. Resawing requires a higher tension than regular straight cutting. If the tension is inadequate, the blade deflects in the cut and tends to cut a curve in the workpiece. It is acceptable to increase the tension for resawing operations if the blade is wandering. It is important to note that the feed rate, sharpness, and tooth geometry can all contribute to poor cut quality when resawing.

Adjusting the tracking

It is necessary to check and adjust the tracking every time the blade is changed. This must be done with the machine locked out, it is never performed with the machine running.

- Lock out the machine.
- Open the covers to access the top and bottom wheels.
- Use your hand to slowly turn the upper wheel. Use extreme caution when doing this, as your fingers can catch on the parts of the saw behind the wheel and injure you. Be aware that the blade is also exposed and can still be hazardous.
- Observe the position of the blade on the tires. It should be riding on the top of the crown, in the centre.
- If the blade is favouring the front or back of the wheel, turn the tracking control adjustment a small amount while turning the wheel. You will see the blade move to the front or back.
- Adjust the tracking until the blade is running reliably in the centre of the wheel. Continue to turn the wheel a few times to confirm it is running in the same place.

It is important to note that the blade must initially be installed on the saw in the centre of the wheel. Blades that are badly installed cannot be fixed by adjusting the tracking. Lower the tension, reposition, then check the tracking again.

Be extremely cautious when rotating the wheel by hand. There are pinch points in the saw that can badly damage fingers.

Adjusting for drift

The term drift refers to the alignment of the fence and mitre slot with respect to the cutting path of the blade. Because the position of the blade on the wheels, which are crowned, can vary, the teeth will angle slightly to the left or to the right if the blade is not centred. This potential change means the blade must be checked for alignment to ensure the blade is running parallel to the fence and mitre slot every time the blade is changed. Drift can also occur if the blade is dull, especially if the teeth are duller on one side than the other.

To check for drift, run a piece of scrap wood (it should have one flat face and one straight edge) along the fence and into the blade a few inches. Hold the wood in place against the fence and stop the saw. Look at the

blade relative to the kerf. The back of the blade should not be touching the wood on either side of the kerf. It should be very close to parallel in the kerf along the width of the blade.

There are two strategies for dealing with drift. The first is to install the blade, and adjust the fence to the blade. This method works well as long as the mitre gauge is not being used, as this aligns the blade to the fence only, not the mitre slot. The second strategy is to install the blade carefully, ensuring that the centre line of the blade is exactly centered on the centre line of the wheel. The blade will track in the same place every time. It is preferable to use this method, as alignment of the mitre slot to the blade is important when the mitre gauge and other jigs that use the mitre slot are used on the bandsaw. The first time using this method, it may be necessary to set-up the saw by aligning the mitre slot in the table to the blade. This is done by loosening the table bolts, refer to the saw's manual. This only needs to be done once.

To adjust for drift by positioning the blade, install the blade as centred as possible on the wheels. The centre line of the blade is halfway between the leading edge of the teeth and the back edge of the blade. The upper drive wheel is the place of critical alignment, the exact position on the lower wheel is less critical as the tracking adjustment on the upper wheel will bring the blade on the lower wheel into alignment. Align the fence parallel to the mitre slot, then check with a scrap of wood as described above. If the blade is not running parallel to the kerf, lock out the saw, back off the blade tension, reposition and re-tension the blade. Make test cuts until the alignment is correct.

To adjust for drift by adjusting the fence, locate the fence squaring adjustments. Loosen them off, and adjust the fence to make the blade parallel to the kerf. Tighten the fence, and re-check for drift. Keep adjusting the fence relative to the blade until the kerf and blade are in alignment.

Setting and adjusting the guides

The exact procedure will vary depending on the type of guides on the saw, refer to the manual for your saw's adjustments. In all cases, back off all the guides to start.

- Check the set-back. When changing between different blade widths, the guides will need to be adjusted so there is proper set-back between the side guides and the teeth. If the guides contact the teeth, they will be damaged and will also dull the blade. They should be set just back from the bottom of the gullets.

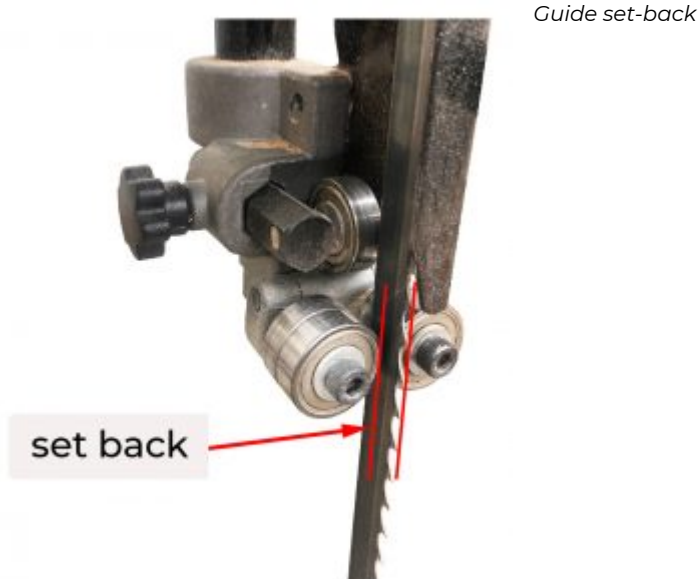

- Adjust the thrust bearings. The thrust bearing should not contact the back edge of the blade until material is fed into it. They should be set with a few thousandths of an inch clearance between the bearing and the blade, so that as the saw is running free, the bearing is not engaged. This increases the life of the bearing, and reduces heat due to friction. Remember to set the guides below the table.
- Adjust the side guides. The tolerances may vary depending on the type of guide, refer to the saw's manual. In all cases, the guide should allow the blade to run freely, without drag. The closer the tolerance on the side guides, the more accurate the blade will track. Remember to set the guides below the table.
- Before powering the saw, carefully rotate the upper wheel to ensure the guides allow the blade to run easily through them. Check that the thrust bearing does not contact the back of the blade. Be extremely cautious when rotating the wheel by hand. There are pinch points in the saw that can badly damage fingers.
- It is recommended that the guides be checked for alignment often. Some bandsaw guides have a tendency to loosen or come out of alignment with use.

20. Parts of the Drill Press



One or more interactive elements has been excluded from this version of the text. You can view them online here: <https://pressbooks.bccampus.ca/woodworkingmachinery/?p=685#oembed-1>

Parts of the drill press



Base

The base is bolted to the column and supports the machine. It may be bolted to the floor to prevent rocking and increase stability.

Column

The column is accurately machined to accept the mechanism that supports the table and allows it to raise and lower. The head of the drill press is attached to the top of the column.

Head

The head is the portion of the machine that houses the drive and control components including the pulleys and belts, quill, feed wheel, etc.

Table, table clamp

The table supports the work, and can be raised or lowered on the column to adjust for different material thicknesses and tooling clearances. There is a collar attached to the table that clamps to the column. Most drill presses, especially larger ones, make use of a **rack and pinion** mechanism to allow the loosening of the clamp without the heavy table sliding down the column. In some woodworking shops, an auxiliary shop made table is added that allows the workpiece to be backed up as the drill bit exits the workpiece on the bottom side. This provides a zero-clearance backing which helps prevent tear-out.

When drilling through the work, ensure that the bit is positioned over the hole in the centre of the table. When using an auxiliary table, the bit is usually allowed to just-pass through the work, into the auxiliary table.

Most drill presses allow for the table to tilt to allow for angled drilling operations. There is a lock mechanism, usually a bolt, that holds the table at 90° to the bit or any angle between 90° and 45°. The table tilts both ways, and it is possible to rotate the table to a vertical position to end-drill. There is usually a tilt scale and pointer to indicate the angle of the table. When the table is level, or at 90° to the shaft of the drill bit, the scale reads 0°. The scale has readings to the left and right. There may be an indexing pin that holds the table in its horizontal position, it must be removed before tilting the table.

Fence

A back fence is useful for aligning repeated holes in a workpiece. Some drill presses come with a fence, some do not. A shop-made fence can easily be made to increase functionality and in the case of drilling using large diameter drills, safety.

Power on/off

The switch powers the motor on and off. It is usually located on the front of the head in an easily accessible location.

Quill and spindle

The quill is located inside the head, and is the hollow shaft that surrounds the spindle. The spindle is the rotating shaft that the drill chuck is mounted on. The quill, spindle and chuck moves up and down as one unit during drilling operations, and is attached to a spring return mechanism that always returns it to the head of the machine.

Quill clamp

The quill clamp locks the quill in position at a particular height.

Chuck

The chuck holds the tooling. It usually has three jaws and is known as a geared chuck meaning it uses a geared key to tighten the tooling. Keyless chucks may also be found on drill presses. The chuck is moved downward by means of simple rack-and-pinion gearing worked by the feed wheel or lever. The feed lever is returned to its normal position by means of a coil spring. You can lock the feed and pre-set the depth to which it can travel.

Feed wheel

The feed wheel or lever rotates the pinion shaft, moving the spindle and chuck up and down.

Depth stop

The adjustable depth stop allows holes to be drilled to a specific depth. When in use, it allows the quill to be stopped at a point along its travel. There are some depth stops that allow the spindle/chuck to be secured in a lowered position, which can be useful when setting up the machine.

Drive mechanism and speed control

Woodworking drill presses commonly use stepped pulleys and a belt(s) to transmit force from the motor to the spindle. In this type of drill press, the speed is changed by moving the belt up or down the stepped pulley. Some drill presses use an infinitely variable pulley that allows for speed adjustments without having to change belts as in a stepped pulley drive. See [Use of the drill press](#) for instructions on adjusting speeds.

21. Tooling

22. Use of the Drill Press

23. Common Operations

24. Set Up and Maintenance

This is where you can add appendices or other back matter.